



SmarterGlass

state-of-the-art display solutions

www.smarterglass.com
978 997 4104
sales@smarterglass.com

Product Specification

SPECIFICATION FOR APPROVAL

- (●) Preliminary Specification
() Final Specification

This Product must be used for a TV Application
This is not designed for the public display.

Title	32.0" WXGA TFT LCD
--------------	---------------------------

BUYER	
MODEL	

SUPPLIER	LG.Philips LCD Co., Ltd.
*MODEL	LC320W01
SUFFIX	SLA1

*When you obtain standard approval,
please use the above model name without suffix

APPROVED BY	SIGNATURE DATE
/	_____
/	_____
/	_____

Please return 1 copy for your confirmation with
your signature and comments.

APPROVED BY	SIGNATURE DATE
H.I. Jang / Senior Manager	_____
REVIEWED BY	_____
PREPARED BY	_____
D.W. Lee / Engineer	_____

TV Product Development Dept.
LG. Philips LCD Co., Ltd

Product Specification

CONTENTS

Number	ITEM	Page
	COVER	1
	CONTENTS	2
	RECORD OF REVISIONS	3
1	GENERAL DESCRIPTION	4
2	ABSOLUTE MAXIMUM RATINGS	5
3	ELECTRICAL SPECIFICATIONS	6
3-1	ELECTRICAL CHARACTERISTICS	6
3-2	INTERFACE CONNECTIONS	8
3-3	SIGNAL TIMING SPECIFICATIONS	12
3-4	SIGNAL TIMING WAVEFORMS	13
3-5	COLOR INPUT DATA REFERENCE	14
3-6	POWER SEQUENCE	15
4	OPTICAL SPECIFICATIONS	17
5	MECHANICAL CHARACTERISTICS	21
6	RELIABILITY	24
7	INTERNATIONAL STANDARDS	25
7-1	SAFETY	25
7-2	EMC	25
8	PACKING	26
8-1	DESIGNATION OF LOT MARK	26
8-2	PACKING FORM	26
9	PRECAUTIONS	27
9-1	MOUNTING PRECAUTIONS	27
9-2	OPERATING PRECAUTIONS	27
9-3	ELECTROSTATIC DISCHARGE CONTROL	28
9-4	PRECAUTIONS FOR STRONG LIGHT EXPOSURE	28
9-5	STORAGE	28
9-6	HANDLING PRECAUTIONS FOR PROTECTION FILM	28

Product Specification

1. General Description

The LC320W01 is a Color Active Matrix Liquid Crystal Display with an integral External Electrode Fluorescent Lamp(EEFL) backlight system. The matrix employs a-Si Thin Film Transistor as the active element. It is a transmissive type display operating in the normally black mode. It has a 31.51 inch diagonally measured active display area with WXGA resolution (768 vertical by 1366 horizontal pixel array). Each pixel is divided into Red, Green and Blue sub-pixels or dots which are arranged in vertical stripes. Gray scale or the luminance of the sub-pixel color is determined with a 8-bit gray scale signal for each dot, thus presenting a palette of more than 16.7M(true) colors.

It has been designed to apply the 8-bit 1-port LVDS interface.

It is intended to support LCD TV, PCTV where high brightness, super wide viewing angle, high color gamut, high color depth and fast response time are important.

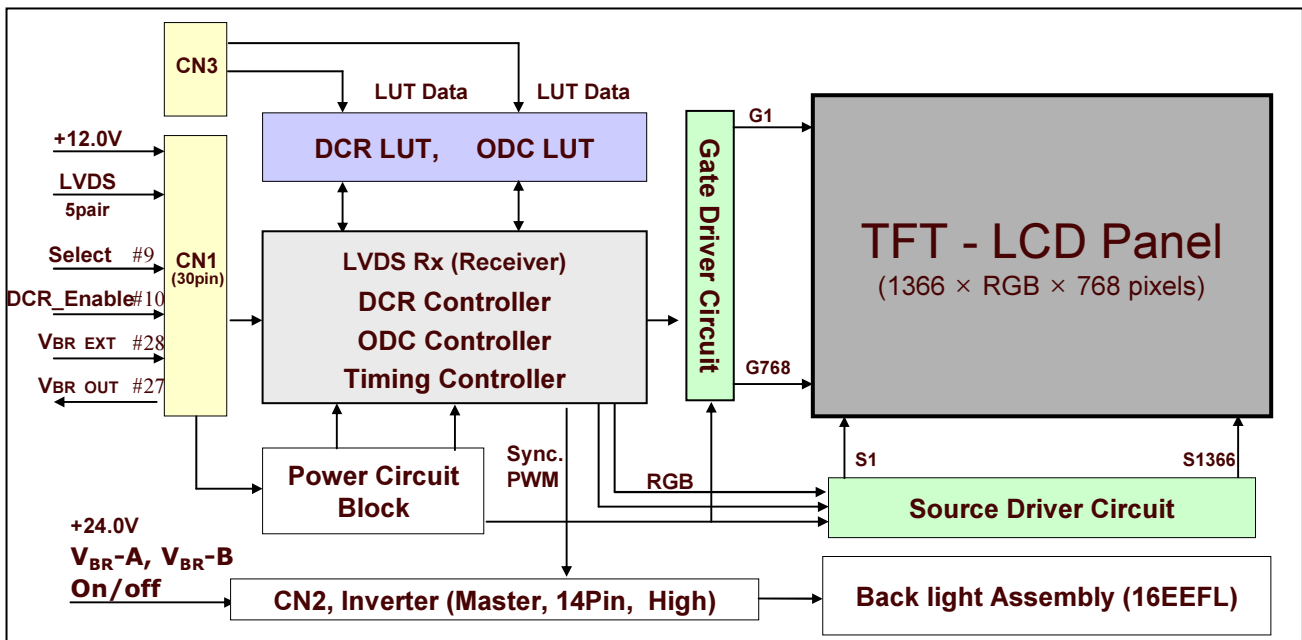

General Features

Active Screen Size	31.51 inches(800.4mm) diagonal
Outline Dimension	760.0 mm(H) x 450.0 mm(V) x 48.0 mm(D) (Typ.)
Pixel Pitch	170.25 μ m x 510.75 μ m x RGB
Pixel Format	1366 horiz. by 768 vert. pixels RGB stripe arrangement
Color Depth	8bit, 16,7 M colors
Luminance, White	500 cd/m ² (Center 1 point) (Typ.)
Viewing Angle (CR>10)	Viewing angle free (R/L 178(Typ.), U/D 178(Typ.)) (ORT polarizer applied)
Power Consumption	Total 113.70Watt (Typ.) (Logic=3.70 W, Lamp=110W [I _{BL} =112mA])
Weight	6,050g (Typ.)
Display Operating Mode	Transmissive mode, normally black
Surface Treatment	Hard coating(3H), anti-glare treatment of the front polarizer

Product Specification

2. Absolute Maximum Ratings

The following items are maximum values which, if exceeded, may cause faulty operation or damage to the LCD module.

Table 1. ABSOLUTE MAXIMUM RATINGS

Parameter		Symbol	Value		Unit	Remark
			Min	Max		
Power Input Voltage	LCM	V _{LCD}	-0.3	+14.0	V _{dc}	at 25 ± 2 °C
	Backlight inverter	V _{BL}	21.6	+27.0	V _{dc}	When Operating
ON/OFF Control Voltage		V _{ON/OFF}	-0.3	+5.5	V _{dc}	
Brightness Control Voltage		V _{Br}	-0.3	+5.0	V _{dc}	
Operating Temperature		T _{OP}	0	50	°C	Note 1,2
Storage Temperature		T _{ST}	-20	60	°C	
Operating Ambient Humidity		H _{OP}	10	90	%RH	
Storage Humidity		H _{ST}	10	90	%RH	

Note 1. Temperature and relative humidity range are shown in the figure below.

Wet bulb temperature should be 39 °C Max, and no condensation of water.

- Abnormal visual problems by the surface temperature of front panel side can be occurred in specific range (higher than 55 °C). But materials (ex : polarize stuff) are not damaged permanently in this range.

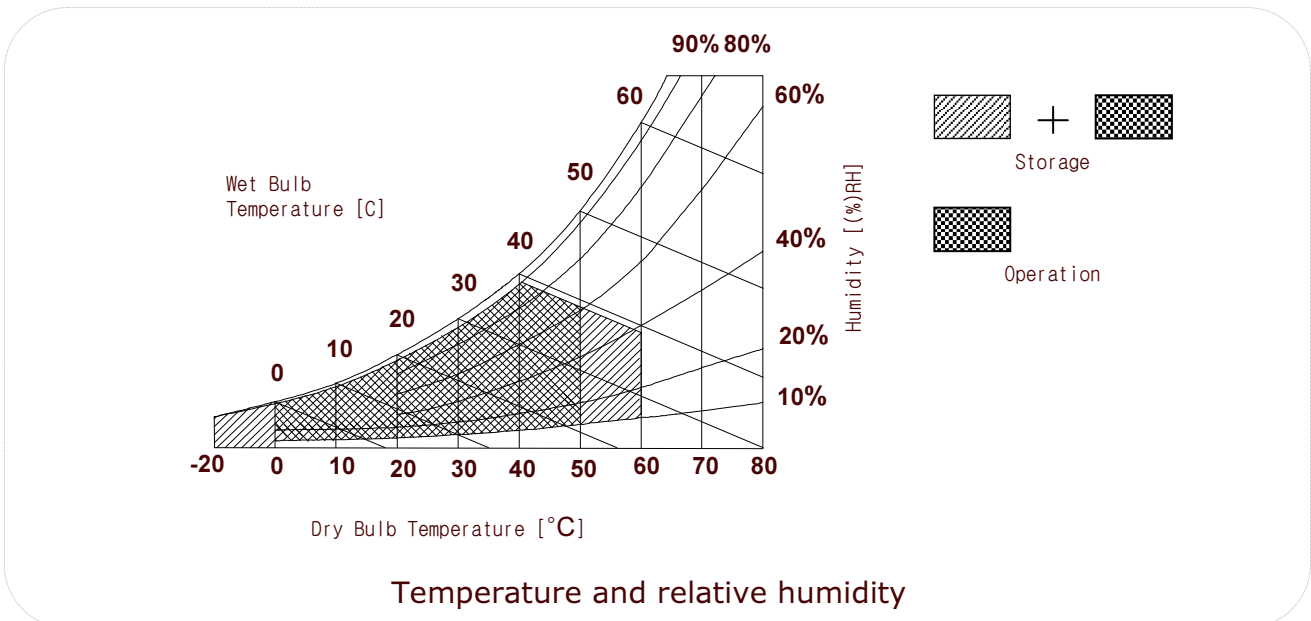

Product Specification

3. Electrical Specifications

3-1. Electrical Characteristics

It requires two power inputs. One is employed to power for the LCD circuit. The other input power for the EEFL/Backlight is to power inverter.

Table 2-1. ELECTRICAL CHARACTERISTICS

Parameter	Symbol	Value			Unit	Note
		Min	Typ	Max		
MODULE :						
Power Input Voltage	V _{LCD}	11.4	12.0	12.6	Vdc	
Power Input Current	I _{LCD}	-	310	403	mA	1
		-	380	494	mA	2
Power Consumption	P _{LCD}	-	3.7	4.8	Watt	1
Rush current	I _{RUSH}	-	-	3.0	A	3

- Notes :
1. The specified current and power consumption are under the $V_{LCD}=12.0V$, $25 \pm 2^{\circ}C$, $f_V=60Hz$ condition whereas mosaic pattern(8 x 6) is displayed and f_V is the frame frequency.
 2. The current is specified at the maximum current pattern.
 3. The duration of rush current is about 2ms and rising time of power input is 1ms (min.).

White : 255Gray
Black : 0Gray

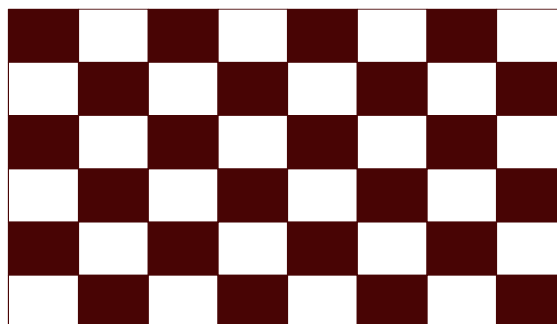

Mosaic Pattern(8 x 6)

Product Specification

Table 2_2. ELECTRICAL CHARACTERISTICS

Parameter	Symbol	Condition	Value			Unit	Note
			Min.	Typ.	Max.		
Inverter :							
Input Voltage	V_{BL}		22.8	24.0	25.2	V_{DC}	
Permissible Input Ripple Voltage	V_{RP}		-	-	400	mVp-p	
Input Current	I_{BL}	$V_{BR-A(max)} = 3.3V$	-	5.0	5.5	A	1, 3
		$V_{BR-A(Typ)} = 1.65V$	-	4.58	5.1	A	1, 3
Power Consumption	P_{BL}	$V_{BL}=24V, V_{BR-A}=3.3V$		120	132	Watt	1, 3
		$V_{BL}=24V, V_{BR-A}=1.65V$	-	110	122		
B/L on/off control	$V_{ON/OFF}$	Lamp ON = High	2.8(TBD)	-	5.25	V_{DC}	
		Lamp OFF =Low	-0.3		0.5	V_{DC}	
Brightness Adj (Analog mode)	V_{BR-A}	$V_{BL}=24V$ $V_{BR-B} = 3.3V$	0	1.65	3.3	V_{DC}	
Brightness Adj (Burst mode)	V_{BR-B}	$V_{BL}=24V$ $V_{BR-A} = 1.65V$	0	-	3.3	V_{DC}	2
Lamp							
Life Time		$V_{BR-A}=1.65V$	50,000	60,000	-	Hrs	3

Note : 1. The specified current and power consumption are under the typical supply Input voltage, 24.0V.
after 2hr aging with $V_{BR-A} = 1.65V$ & $V_{BR-B} = 3.3V$.

2. Brightness Control.

This V_{BR-B} Voltage control brightness.

V_{BR-B} Voltage	Function
3.3V	Maximum Brightness (100%)
0V	Minimum Brightness.(20%)

3. Specified values are for a single lamp which is aligned horizontally.

The Life Time is determined as the time at which brightness of the lamp is 50% compared to that of initial value at the typical lamp current ($V_{BR-A} = 1.65V$) on condition of continuous operating at $25 \pm 2^{\circ}C$.

Product Specification

3-2. Interface Connections

This LCD module employs two kinds of interface connection, a 30-pin connector is used for the module electronics and one 14-pin connectors are used for the integral backlight system.

3-2-1. LCD Module

- LCD Connector(CN1) : FI-X30SSL-HF or Equivalent (Manufactured by JAE)
- Mating Connector : FI-X30C2L or Equivalent (Manufactured by JAE)

Table 3. MODULE CONNECTOR(CN1) PIN CONFIGURATION

Pin No.	Symbol	Description	Note
1	VLCD	Power Supply +12.0V	
2	VLCD	Power Supply +12.0V	
3	VLCD	Power Supply +12.0V	
4	VLCD	Power Supply +12.0V	
5	GND	Ground	
6	GND	Ground	
7	GND	Ground	
8	GND	Ground	
9	Select	Select LVDS Data format	1
10	DCR Enable	Dynamic CR Enable ('L' or 'NC' = Disable , 'H' = Enable)	2, Page 29
11	GND	Ground	
12	RA	LVDS Receiver Signal()	
13	RA+	LVDS Receiver Signal(+)	
14	GND	Ground	
15	RB	LVDS Receiver Signal()	
16	RB+	LVDS Receiver Signal(+)	
17	GND	Ground	
18	RC	LVDS Receiver Signal()	
19	RC+	LVDS Receiver Signal(+)	
20	GND	Ground	
21	RCLK	LVDS Receiver Clock Signal()	
22	RCLK+	LVDS Receiver Clock Signal(+)	
23	GND	Ground	
24	RD	LVDS Receiver Signal()	
25	RD+	LVDS Receiver Signal(+)	
26	GND	Ground	
27	VBR_OUT	VBR output form LCD module	
28	VBR_EXT	External VBR input from System to LCD module	
29	GND	Ground	
30	GND	Ground	3

Note: 1. If the pin no. 9 is Ground, Interface format is "LG", and if the pin no. 9 is Vcc(3.3V), Interface format is "DISM". See page 9 and 10.

2. When #10 pin is no connection, DCR is disabled.

3. The pin no. 30 is necessary for LCD test.

When LVDS signals are abnormal operation more than 3-Vsync times and power 12V is supplied,

'Open' or 'Vcc' : LCD operate itself some test patterns.(AGP – Auto Generation Pattern)

'Ground' : LCD operate itself a black pattern. (NSB – No Signal Black)

LPL recommend 'Ground' for NSB.

4. All GND (ground) pins should be connected together, which should be also connected to the LCD module's metal frame.

5. All VLCD (power input) pins should be connected together.

6. Input Levels of LVDS signals are based on the IEA 664 Standard.

Product Specification

Table 4. REQUIRED SIGNAL ASSIGNMENT FOR LVDS TRANSMITTER (Pin9="L" or "Open")

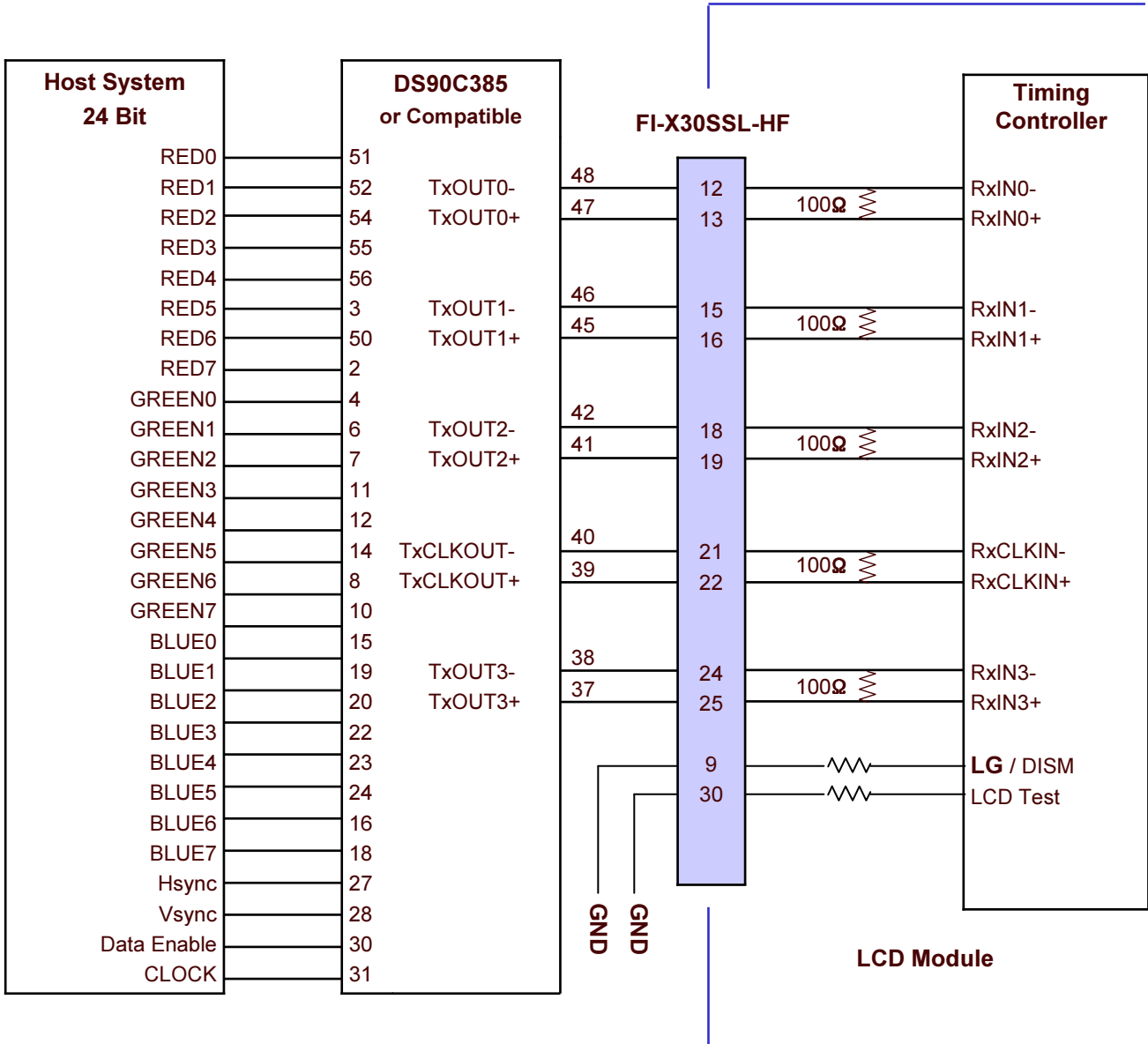

- Note: 1. The LCD Module uses a 100 Ohm [Ω] resistor between positive and negative lines of each receiver input.
 2. Refer to LVDS Transmitter Data Sheet for detail descriptions. (DS90C385 or Compatible)
 3. '7' means MSB and '0' means LSB at R,G,B pixel data.

Product Specification

Table 5. REQUIRED SIGNAL ASSIGNMENT FOR LVDS TRANSMITTER (Pin9="H")

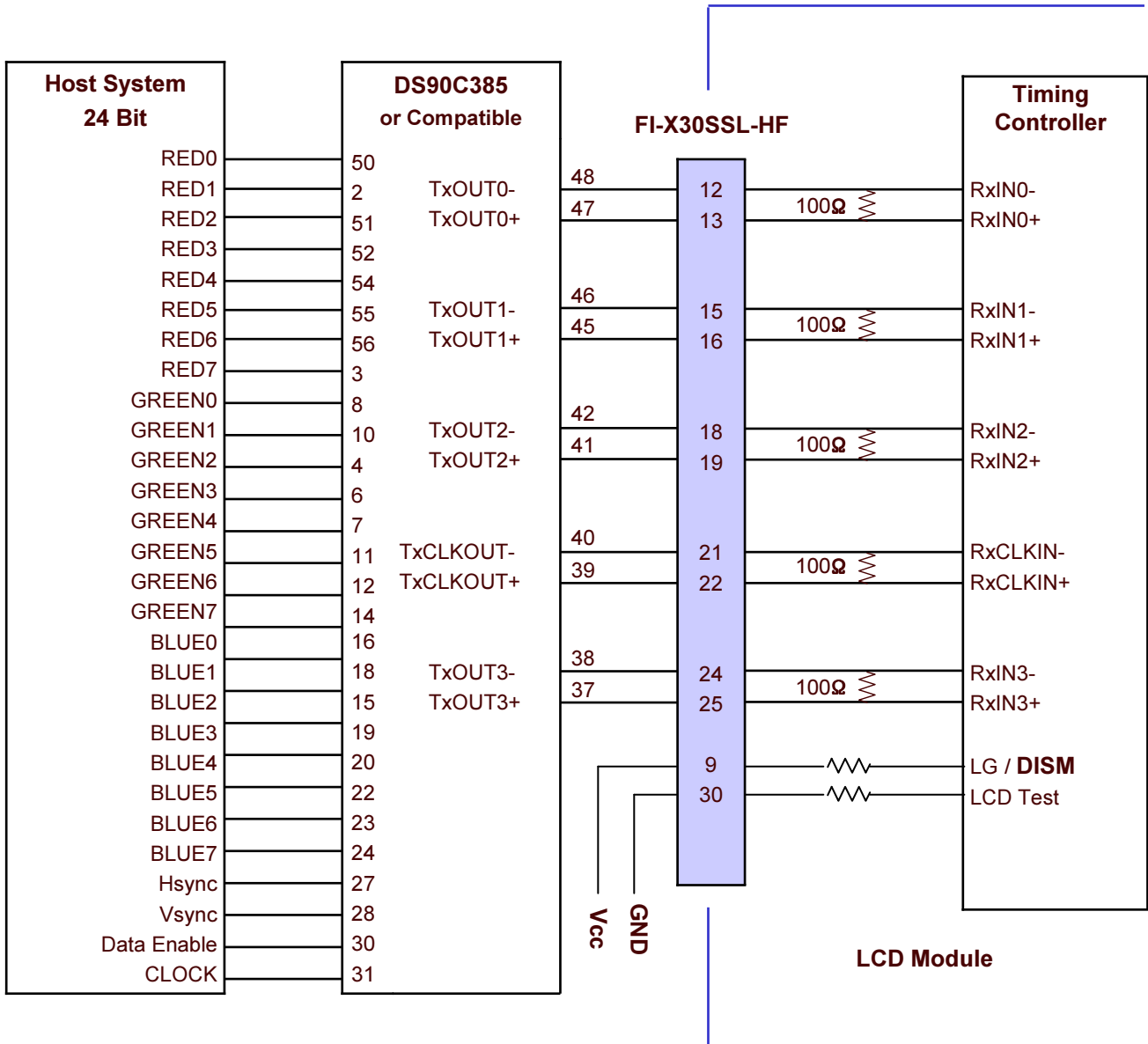

- Note: 1. The LCD Module uses a 100 Ohm [Ω] resistor between positive and negative lines of each receiver input.
 2. Refer to LVDS Transmitter Data Sheet for detail descriptions. (DS90C385 or Compatible)
 3. '7' means MSB and '0' means LSB at R,G,B pixel data.

Product Specification

3-2-2. Backlight Inverter

The inverter connector is 20022WR-14B1 side entry type (manufactured by YeonHo) or equivalent
The pin configuration for the 14 pin connector is shown in the table below.

Table 5. INVERTER CONNECTOR PIN CONFIGURATION

Pin	Symbol	Signal assignment		Note
		Master(CN2)	Slave(CN3)	
1	VBL	24V Power Input	24V Power Input	
2	VBL	24V Power Input	24V Power Input	
3	VBL	24V Power Input	24V Power Input	
4	VBL	24V Power Input	24V Power Input	
5	VBL	24V Power Input	24V Power Input	
6	GND	GROUND	GROUND	
7	GND	GROUND	GROUND	
8	GND	GROUND	GROUND	
9	GND	GROUND	GROUND	
10	GND	GROUND	GROUND	
11	V _{BR A}	Analog dimming voltage for PWM amplitude control	Don't care	0V : 90% (min) 1.65V : 100% (Typ) 3.3V : 110% (max) Open(NC) : 1.65V
12	V _{ON/OFF}	Backlight ON/OFF control	Don't care	ON : 2.8~ 5.25V OFF : 0.0 ~ 0.8V
13	V _{BR B}	Burst dimming Voltage for PWM duty control	No Pin	0V : 20% (min) 3.3V : 100% (max)
14	Status	Using Status output	No pin	3.0V to 5.0V output (Normal), 0V to 0.7V output (Abnormal)

1. Connector
 1) Connector(Receptacle)
 : 20022WR-14B1 (YeonHo)
 2) Mating Connector(Plug)
 : PHR14 (JST) &
 PHR12 (JST)

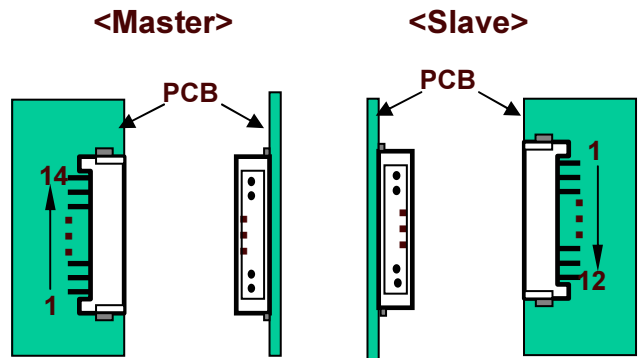

Product Specification

3-3. Signal Timing Specifications

This is the signal timing required at the input of the LVDS transmitter. All of the interface signal timing should be satisfied with the following specification for its proper operation.

Table 7. TIMING TABLE

ITEM		Symbol	Min.	Typ.	Max.	Unit	Note
Clock	Frequency	f_{CLK}	63	72.3	80	MHz	
Hsync	Frequency	f_H	39	47.4	53	KHZ	
	Display Valid	t_{HV}	1366	1366	1366	Clks	
	Blank	$t_{HT}-t_{HV}$	80	162	474	Clks	
	Total	t_{HT}	1446	1528	1840	Clks	
Vsync	Frequency	f_V	47	60	63	HZ	PAL : 47~53Hz, NTSC : 57~63Hz
	Display Valid	t_{VV}	768	768	768	Lines	
	Blank	$t_{VT}-t_{VV}$	7	22	295	Lines	
	Total	t_{VT}	775	790	1063	Lines	

- Note :
1. The Input of HSYNC & VSYNC signal does not have an effect on normal operation(DE Only Mode). If you use spread spectrum for EMI, add some additional clock to minimum value for clock margin.
 2. The performance of the electro-optical characteristics may be influenced by variance of the vertical refresh rate and the horizontal frequency.
 3. Timing should be set based on clock frequency.

Product Specification

3-4. Signal Timing Waveforms

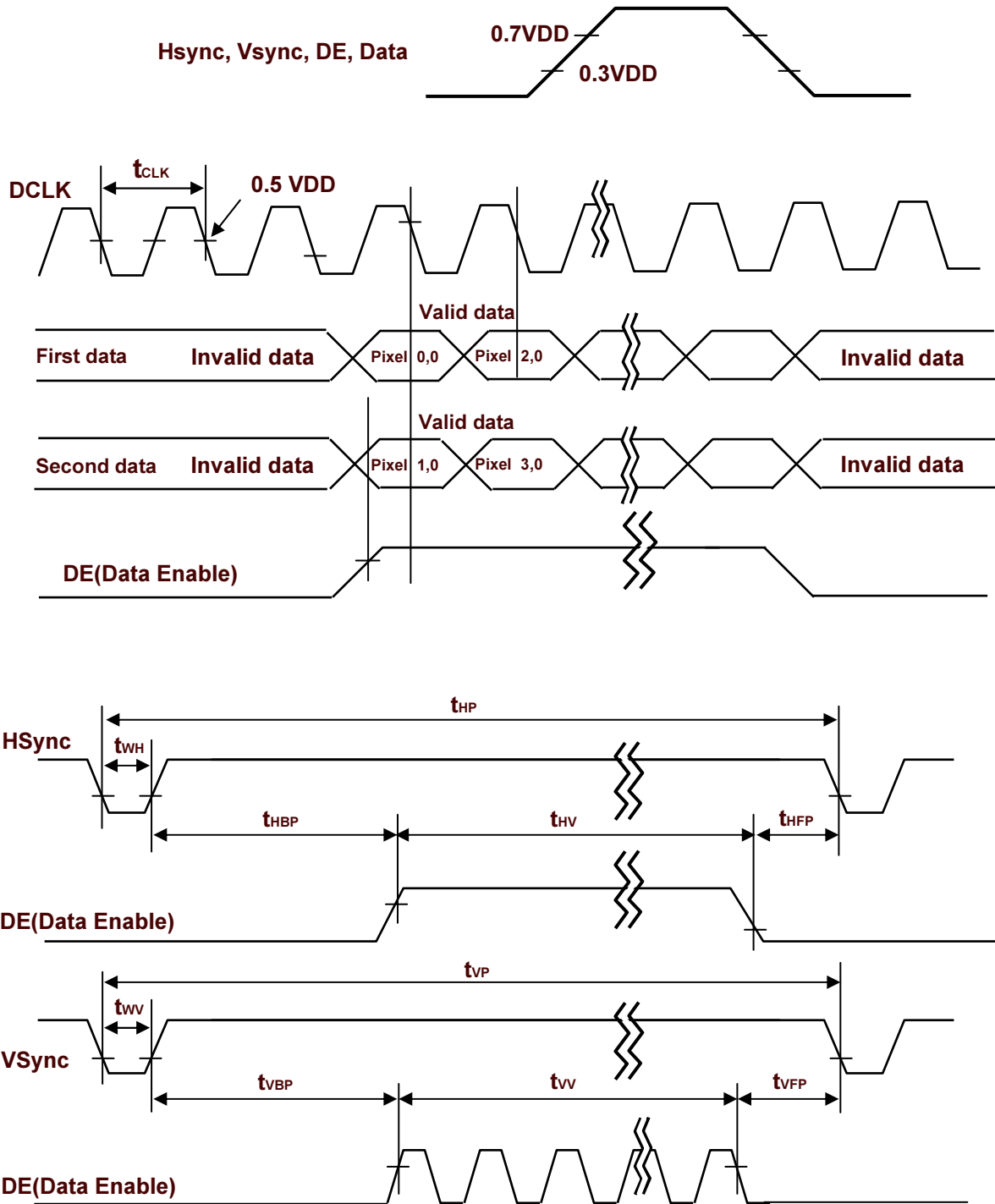

Product Specification

3-5. Color Data Reference

The brightness of each primary color(red,green,blue) is based on the 8-bit gray scale data input for the color the higher the binary input, the brighter the color. The below table provides a reference for color versus data input.

Table 8. COLOR DATA REFERENCE

Color		Input Color Data																							
		RED								GREEN								BLUE							
		MSB				LSB				MSB				LSB				MSB				LSB			
		R7	R6	R5	R4	R3	R2	R1	R0	G7	G6	G5	G4	G3	G2	G1	G0	B7	B6	B5	B4	B3	B2	B1	B0
Basic Color	Black	0	0	0	0	0	0	0	0	0	0	0	0	0	0	0	0	0	0	0	0	0	0	0	0
	Red (255)	1	1	1	1	1	1	1	1	0	0	0	0	0	0	0	0	0	0	0	0	0	0	0	0
	Green (255)	0	0	0	0	0	0	0	0	1	1	1	1	1	1	1	1	0	0	0	0	0	0	0	0
	Blue (255)	0	0	0	0	0	0	0	0	0	0	0	0	0	0	0	0	1	1	1	1	1	1	1	1
	Cyan	0	0	0	0	0	0	0	0	1	1	1	1	1	1	1	1	1	1	1	1	1	1	1	1
	Magenta	1	1	1	1	1	1	1	1	0	0	0	0	0	0	0	0	1	1	1	1	1	1	1	1
	Yellow	1	1	1	1	1	1	1	1	1	1	1	1	1	1	1	1	0	0	0	0	0	0	0	0
	White	1	1	1	1	1	1	1	1	1	1	1	1	1	1	1	1	1	1	1	1	1	1	1	1
RED	RED (000) Dark	0	0	0	0	0	0	0	0	0	0	0	0	0	0	0	0	0	0	0	0	0	0	0	0
	RED (001)	0	0	0	0	0	0	0	1	0	0	0	0	0	0	0	0	0	0	0	0	0	0	0	0
							
	RED (254)	1	1	1	1	1	1	1	0	0	0	0	0	0	0	0	0	0	0	0	0	0	0	0	0
	RED (255)	1	1	1	1	1	1	1	1	0	0	0	0	0	0	0	0	0	0	0	0	0	0	0	0
GREEN	GREEN (000) Dark	0	0	0	0	0	0	0	0	0	0	0	0	0	0	0	0	0	0	0	0	0	0	0	0
	GREEN (001)	0	0	0	0	0	0	0	0	0	0	0	0	0	0	0	1	0	0	0	0	0	0	0	0
							
	GREEN (254)	0	0	0	0	0	0	0	0	1	1	1	1	1	1	1	0	0	0	0	0	0	0	0	0
	GREEN (255)	0	0	0	0	0	0	0	0	1	1	1	1	1	1	1	1	0	0	0	0	0	0	0	0
BLUE	BLUE (000) Dark	0	0	0	0	0	0	0	0	0	0	0	0	0	0	0	0	0	0	0	0	0	0	0	0
	BLUE (001)	0	0	0	0	0	0	0	0	0	0	0	0	0	0	0	0	0	0	0	0	0	0	0	1
							
	BLUE (254)	0	0	0	0	0	0	0	0	0	0	0	0	0	0	0	0	1	1	1	1	1	1	1	0
	BLUE (255)	0	0	0	0	0	0	0	0	0	0	0	0	0	0	0	0	1	1	1	1	1	1	1	1

Note : Users should be input true 8 Bit data streams via LVDS transmitter.

Product Specification

3-6. Power Sequence

3-6-1. LCD Driving circuit

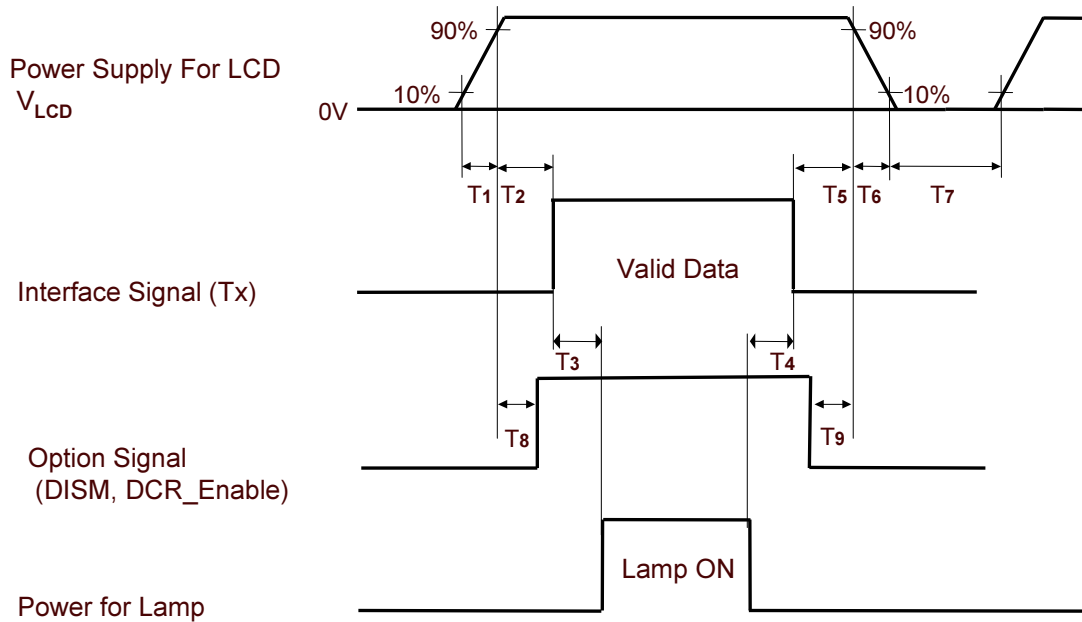

Table 9. POWER SEQUENCE

Parameter	Value			Unit
	Min	Typ	Max	
T1	0.5	-	20	ms
T2	0.5	-	50	ms
T3	200	-	-	ms
T4	200	-	-	ms
T5	0.5	-	50	ms
T6	-	-	300	ms
T7	1.0	-	-	s
T8	0 < T8 < T2			ms
T9	0 < T9 < T5			ms

- Note :
1. Please avoid the floating state of interface signal at invalid period.
 2. When the interface signal is invalid, be sure to pull down the power supply V_{LCD} to 0V.
 3. Flicker would come out when power on-off(T7=1s) is tested over several ten-times.
 4. The case when the T2/T5 exceed maximum specification, it operates protection pattern(Black pattern) till valid signal inputted. There is no reliability problem.
 5. The T3/T4 is recommended value, the case when failed to meet a minimum specification, abnormal display would be shown. There is no reliability problem.
 6. If the on time of option signal(DISM or DCR_Enable) precedes the on time of Power(V_{LCD}), check the LCD logic Power(V_{cc}) is under 0.8V, otherwise it will be happened abnormal display.

Product Specification

3-6-2. On/Off for Inverter

Power Supply For Inverter

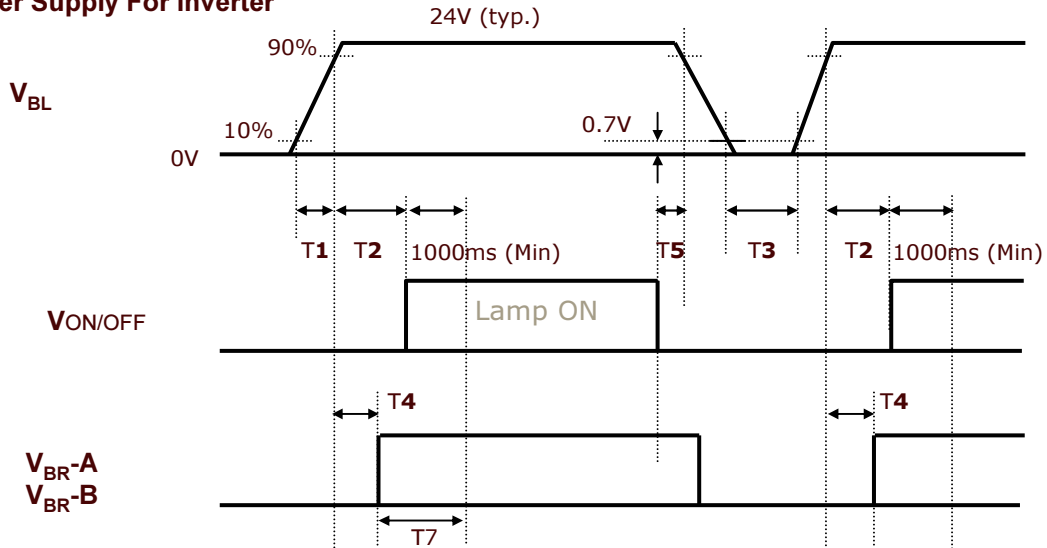

V_{BR-B} : V_{BR-B} has the same sequence with V_{BR-A} .

3-6-3. Deep condition for Inverter

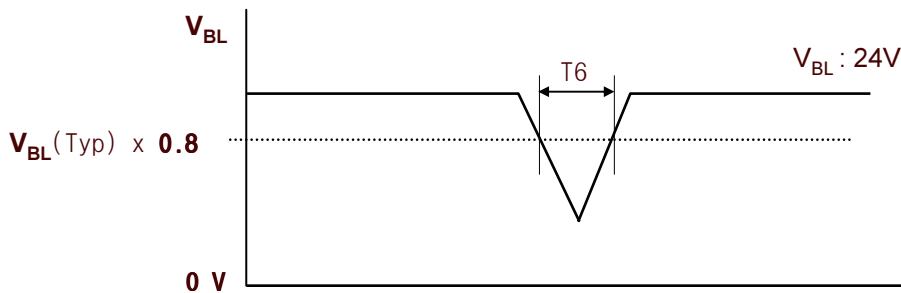

Table 10. Power Sequence for Inverter

Parameter	Values			Units	Remarks
	Min	Typ	Max		
T1	20			ms	1
T2	500			ms	
T3	200			ms	2
T4	0		-	ms	3
T5	10			ms	
T6			10	ms	$V_{BL}(Typ) \times 0.8$
T7	1000			ms	

- Note :
1. T1 describes rising time of 0V to 24V and is not applied at restarting time.
 2. When V_{BL} (24V) is supplied always, there is no reliability problem.
 3. T3(max) is less than T2.
 4. For 1 second after lamp on, V_{BR-B} should be max level(3.3V) and V_{BR-A} is recommended 1.65V.

Product Specification

4. Optical Specification

Optical characteristics are determined after the unit has been 'ON' and for 30 minutes in a dark environment at $25 \pm 2^\circ\text{C}$. The values are specified at an approximate distance 50cm from the LCD surface at a viewing angle of Φ and θ equal to 0° .

It is presented additional information concerning the measurement equipment and method in FIG. 1.

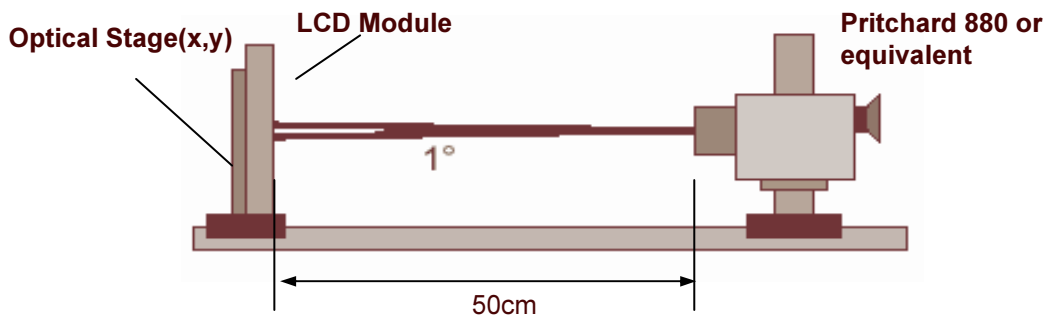

FIG. 1 Optical Characteristic Measurement Equipment and Method

Table 11. OPTICAL CHARACTERISTICS $T_a = 25 \pm 2^\circ\text{C}$, $V_{LCD} = 12.0\text{V}$, $f_v = 60\text{Hz}$, $D_{clk} = 72.3\text{MHz}$, $V_{BR-A} = 1.65\text{V}$, $V_{BR-B} = 3.3\text{V}$

Parameter	Symbol	Value			Unit	Note	
		Min	Typ	Max			
Contrast Ratio	CR	750	1000			1	
	DCR (With AI)	3750	5000				
Surface Luminance, white	L_{WH}	400	500		cd/m^2	2	
Luminance Variation	δ_{WHITE} 5P			1.3		3	
Response Time	Rise Time	Tr_R	-	8	12	ms	4
	Decay Time	Tr_D	-	10	14		
	G to G		-	8	14		
Color Coordinates [CIE1931]	RED	Rx	Typ -0.03	TBD	Typ +0.03		
		Ry		TBD			
	GREEN	Gx		TBD			
		Gy		TBD			
	BLUE	Bx		TBD			
		By		TBD			
	WHITE	Wx		0.279			
Wy		0.292					
Viewing Angle (CR>10)							
	x axis, right ($\phi=0^\circ$)	θ_r	85	89	-	degree	5
	x axis, left ($\phi=180^\circ$)	θ_l	85	89	-		
	y axis, up ($\phi=90^\circ$)	θ_u	85	89	-		
	y axis, down ($\phi=270^\circ$)	θ_d	85	89	-		
Gray Scale							6

Product Specification

Note :

1. Contrast Ratio(CR) is defined mathematically as :

$$\text{Contrast Ratio} = \frac{\text{Surface Luminance with all white pixels}}{\text{Surface Luminance with all black pixels}}$$

It is measured at center 1-point.

DCR is measured when Dynamic CR is enabled.

2. Surface Luminance(L_{WH}) is the luminance value at center 1-point across the LCD surface 50cm from the surface with all pixels displaying white. For more information see the FIG. 2.
3. The variation of surface luminance , δ WHITE is defined as :

$$\delta \text{ WHITE}(5P) = \text{Maximum}(L_{on1}, L_{on2}, L_{on3}, L_{on4}, L_{on5}) / \text{Minimum}(L_{on1}, L_{on2}, L_{on3}, L_{on4}, L_{on5})$$

Where L_{on1} to L_{on5} are the luminance with all pixels displaying white at 5 locations .
 For more information, see the FIG. 2.

4. Response time is the time required for the display to transition from G(N) to G(M) (Rise Time, Tr_R) and from G(M) to G(N) (Decay Time, Tr_D). For additional information see the FIG. 3. ($N < M$)
5. Viewing angle is the angle at which the contrast ratio is greater than 10. The angles are determined for the horizontal or x axis and the vertical or y axis with respect to the z axis which is normal to the LCD module surface. For more information, see the FIG. 4
6. Gray scale specification
 Gamma Value is approximately 2.2. For more information, see the Table 12.

Table 12. GRAY SCALE SPECIFICATION

Gray Level		Luminance [%] (Typ) [Normal]	Luminance [%] (Typ) [DCR]
8bit	10bit		
L0	L0	0.10	0.02 ($V_{BR-A} = 0V, V_{BR-B} = 0V$)
L15	L63	0.32	
L31	L127	1.10	
L47	L191	2.60	
L63	L255	4.90	
L79	L319	8.10	
L95	L383	12.1	
L111	L447	16.7	DCR gray scale is according to inverter dimming voltages.
L127	L511	21.6	
L143	L575	28.0	
L159	L639	35.4	
L175	L703	43.9	
L191	L767	53.3	
L207	L831	64.1	
L223	L895	75.8	
L239	L959	88.0	
L255	L1023	100	

Product Specification

Measuring point for surface luminance & measuring point for luminance variation

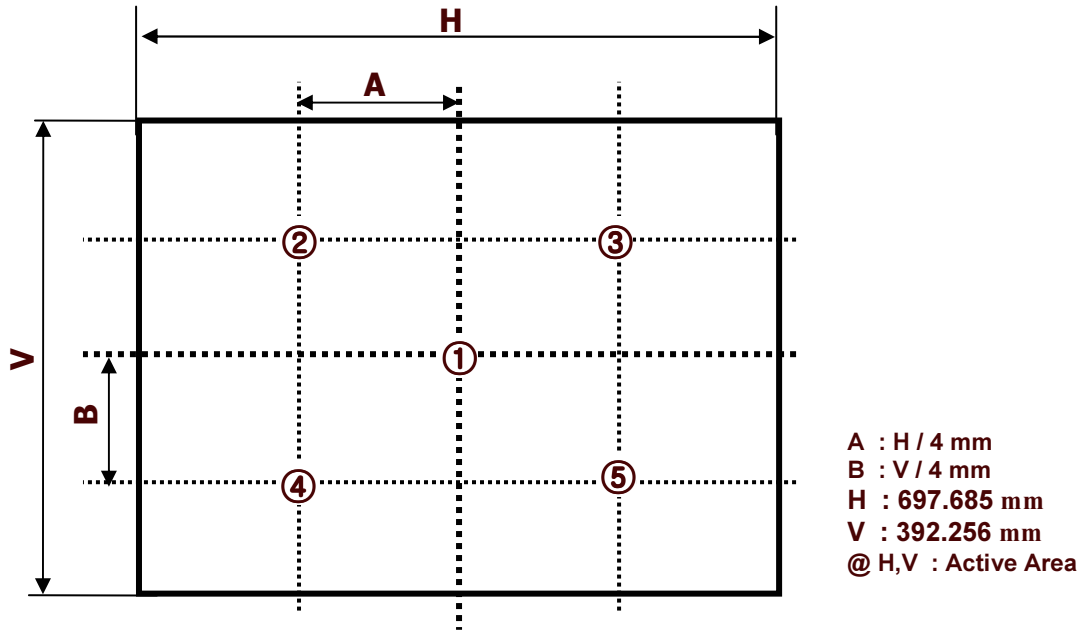

FIG. 2 The Position of Points for Luminance Measure

Response time is defined as the following figure and shall be measured by switching the input signal for “Gray(N)” and “Gray(M)”.

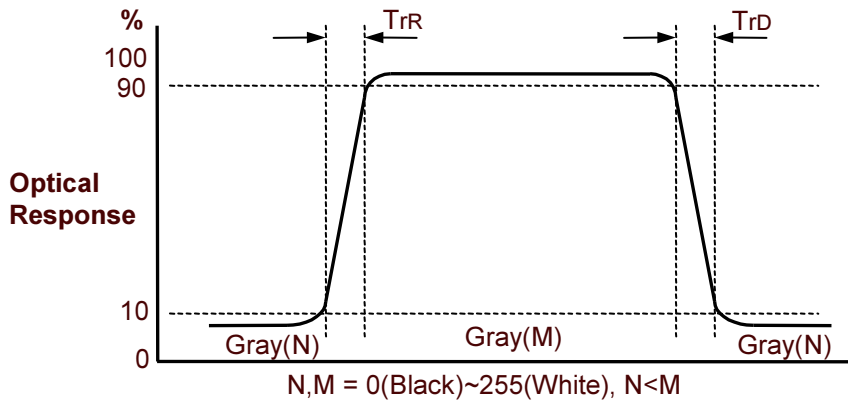

FIG. 3 Response Time

Product Specification

Dimension of viewing angle range

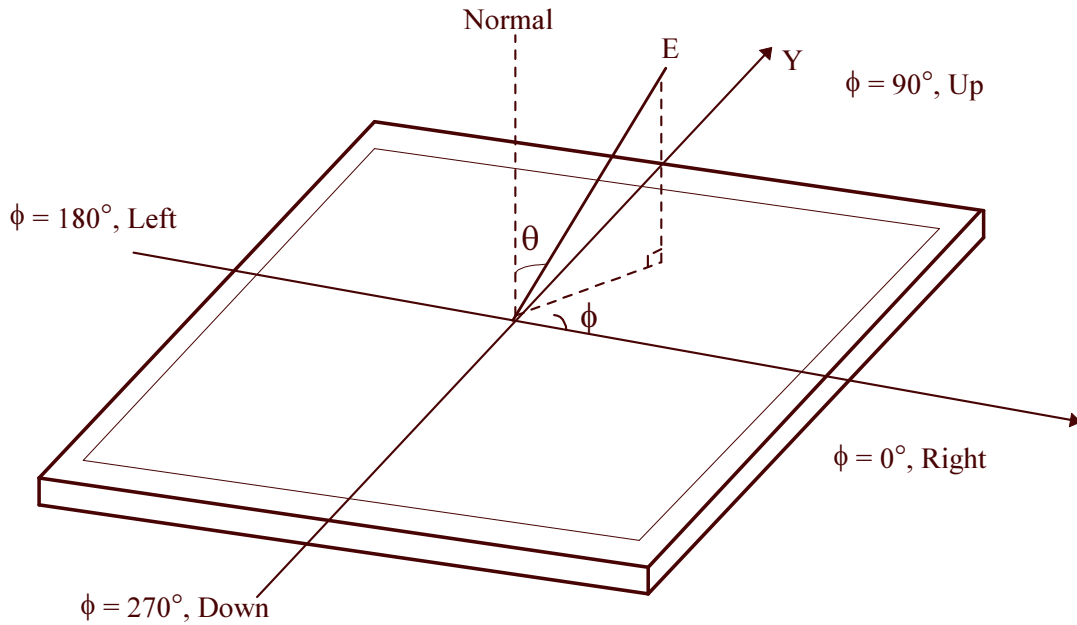

FIG. 4 Viewing Angle

Product Specification

5. Mechanical Characteristics

The following items provide general mechanical characteristics. In addition, the figures in the next page show the detail information of mechanical drawing for LCD module.

Table 13. MECHANICAL CHARACTERISTICS

Outline Dimension	Horizontal	760.0mm
	Vertical	450.0 mm
	Depth	48.0 mm
Bezel Area	Horizontal	703.8mm
	Vertical	398.4mm
Active Display Area	Horizontal	697.685mm
	Vertical	392.256mm
Weight	6,050 g(Typ.), 6,600g(Max)	
Surface Treatment	Hard coating(3H) Anti-glare treatment of the front polarizer	

Notes : Please refer to a mechanic drawing in terms of tolerance at the next page.

Product Specification

<FRONT VIEW>

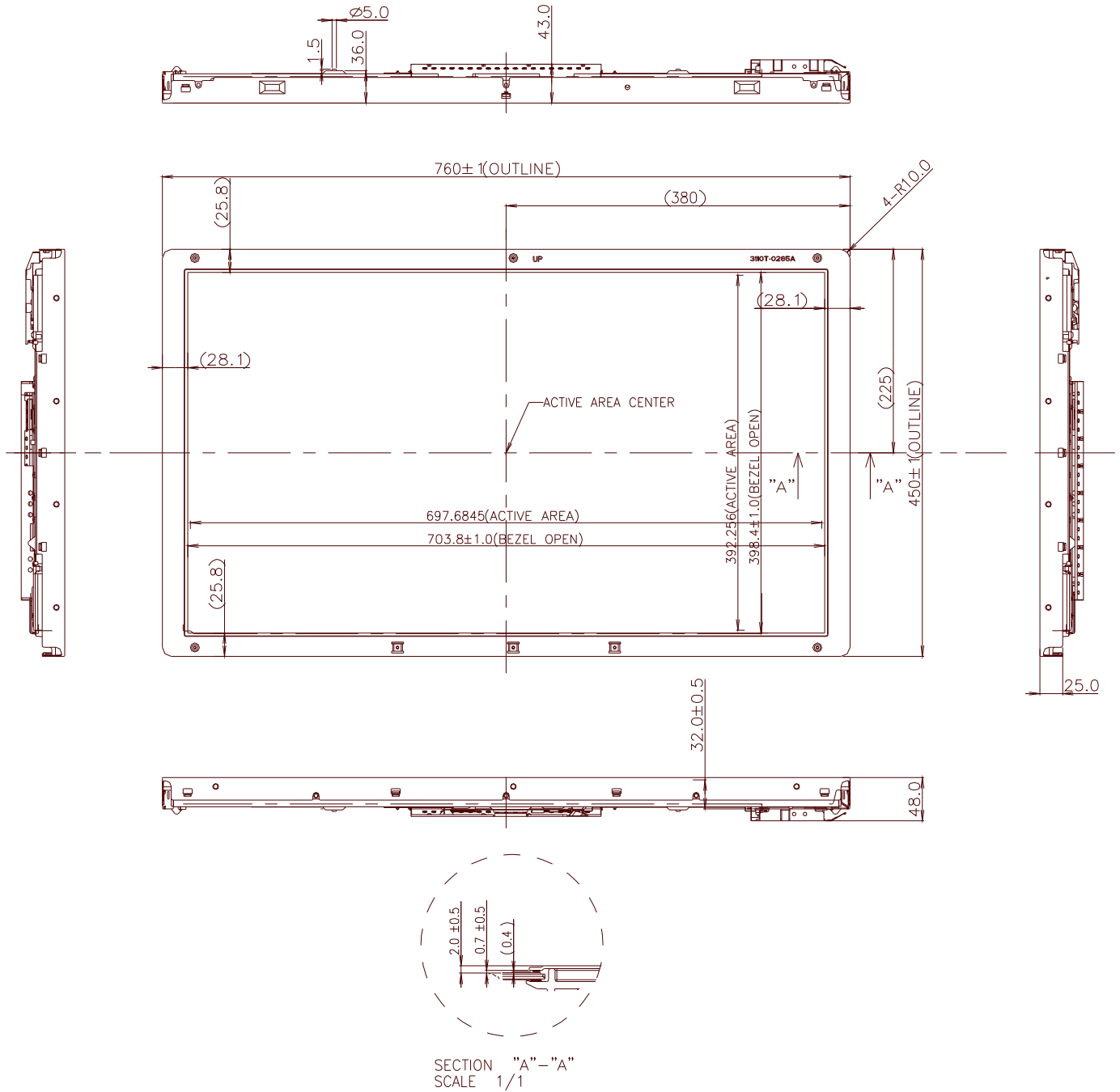

Product Specification

<REAR VIEW>

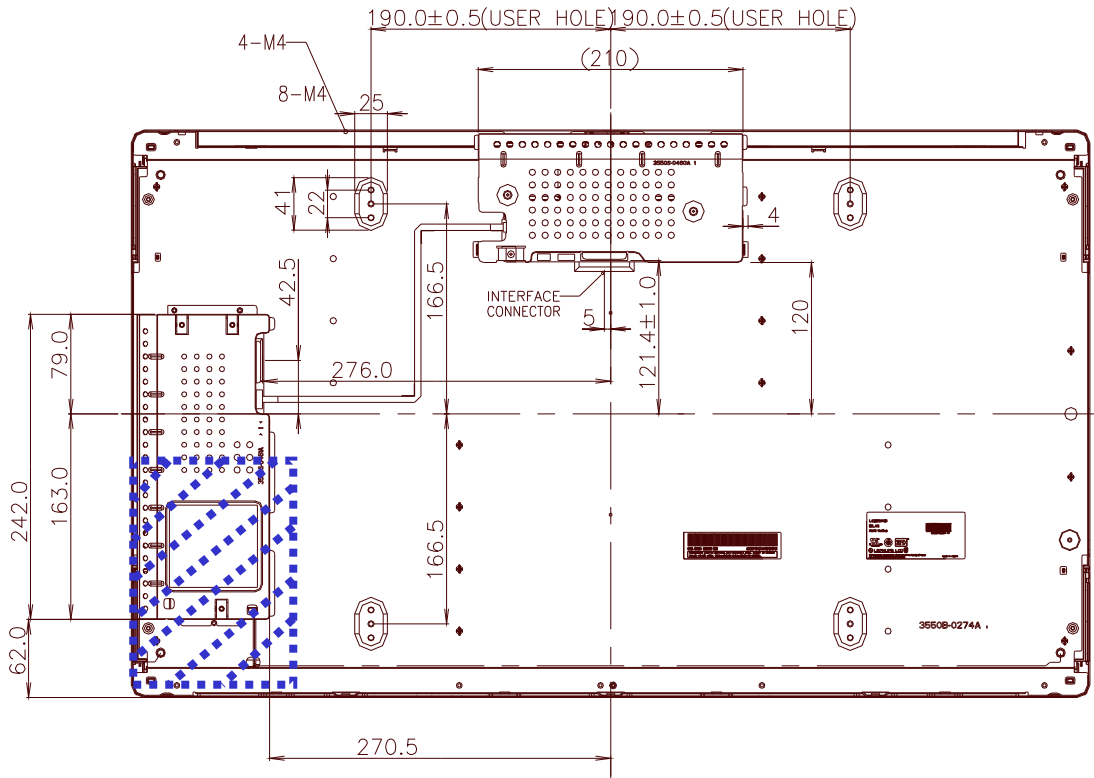

NOTES

1. Unspecified tolerances are to be $\pm 0.5\text{mm}$.
2. This drawing is only preliminary data and can be changed without notice.
3. Tilt and partial disposition tolerance of display area is as following.
 - (1) X-Direction : IA-BI $\leq 1.5\text{mm}$
 - (2) Y-Direction : IC-DI $\leq 1.5\text{mm}$

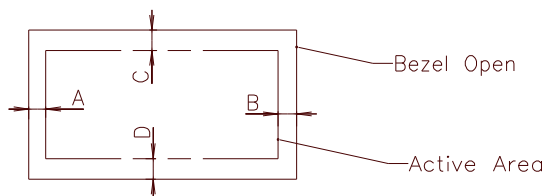

Notes : It should be recommended that any exterior materials do not go passing up the red area slanted. (For example, electrical cable, system board , etc). Otherwise, it could cause that abnormal display happens.

Product Specification

6. Reliability
Table 14. ENVIRONMENT TEST CONDITION

No.	Test Item	Condition
1	High temperature storage test	Ta= 50°C 240h
2	Low temperature storage test	Ta= -20°C 240h
3	High temperature operation test	Ta= 40°C 50%RH 240h
4	Low temperature operation test	Ta= 0°C 240h
5	Vibration test (non-operating)	Wave form : random Vibration level : 1.0Grms Bandwidth : 10-500Hz Duration : X,Y,Z, 10 min One time each direction
6	Shock test (non-operating)	Shock level : 100Grms Waveform : half sine wave, 2ms Direction : ± X, ± Y, ± Z One time each direction
7	Humidity condition Operation	Ta= 40 °C 90%RH 240h
8	Altitude operating storage / shipment	0 - 14,000 feet(4267.2m) 0 - 40,000 feet(12192m)

7. International Standards

7-1. Safety

- a) UL 60065, 7th Edition, dated June 30, 2003, Underwriters Laboratories, Inc., Standard for Audio, Video and Similar Electronic Apparatus.
- b) CAN/CSA C22.2, No. 60065:03, Canadian Standards Association, Standard for Audio, Video and Similar Electronic Apparatus.
- c) IEC60065:2001, 7th Edition CB-scheme and EN 60065:2002, Safety requirements for Audio, Video and Similar Electronic Apparatus..

7-2. EMC

- a) ANSI C63.4 "Methods of Measurement of Radio-Noise Emissions from Low-Voltage Electrical and Electrical Equipment in the Range of 9kHz to 40GHz." American National Standards Institute(ANSI), 1992
- b) CISPR22 "Limits and Methods of Measurement of Radio Interface Characteristics of Information Technology Equipment." International Special Committee on Radio Interference.
- c) EN 55022 "Limits and Methods of Measurement of Radio Interface Characteristics of Information Technology Equipment." European Committee for Electrotechnical Standardization.(CENELEC), 1998 (Including A1: 2000)

Product Specification

8. Packing

8-1. Designation of Lot Mark

a) Lot Mark

A	B	C	D	E	F	G	H	I	J	K	L	M
---	---	---	---	---	---	---	---	---	---	---	---	---

A,B,C : SIZE(INCH)

E : MONTH

G ~ M : SERIAL NO.

D : YEAR

F : FACTORY CODE

Note

1. YEAR

Year	2001	2002	2003	2004	2005	2006	2007	2008	2009	2010
Mark	1	2	3	4	5	6	7	8	9	0

2. MONTH

Month	Jan	Feb	Mar	Apr	May	Jun	Jul	Aug	Sep	Oct	Nov	Dec
Mark	1	2	3	4	5	6	7	8	9	A	B	C

3. FACTORY CODE

Factory Code	Gumi	Nanjing	Paju
Mark	K	C	P

b) Location of Lot Mark

Serial No. is printed on the label. The label is attached to the backside of the LCD module.
This is subject to change without prior notice.

8-2. Packing Form

a) Package quantity in one box : 6 pcs

b) Box size : 848mm(W) X 494mm(D) X 539mm(H)

Product Specification

9. Precautions

Please pay attention to the followings when you use this TFT LCD module.

9-1. Mounting Precautions

- (1) You must mount a module using holes arranged in four corners or four sides.
- (2) You should consider the mounting structure so that uneven force (ex. Twisted stress) is not applied to the module. And the case on which a module is mounted should have sufficient strength so that external force is not transmitted directly to the module.
- (3) Please attach the surface transparent protective plate to the surface in order to protect the polarizer. Transparent protective plate should have sufficient strength in order to resist external force.
- (4) You should adopt radiation structure to satisfy the temperature specification.
- (5) Acetic acid type and chlorine type materials for the cover case are not desirable because the former generates corrosive gas of attacking the polarizer at high temperature and the latter causes circuit break by electro-chemical reaction.
- (6) Do not touch, push or rub the exposed polarizers with glass, tweezers or anything harder than HB pencil lead. And please do not rub with dust clothes with chemical treatment. Do not touch the surface of polarizer for bare hand or greasy cloth. (Some cosmetics are detrimental to the polarizer.)
- (7) When the surface becomes dusty, please wipe gently with absorbent cotton or other soft materials like chamois soaks with petroleum benzine. Normal-hexane is recommended for cleaning the adhesives used to attach front / rear polarizers. Do not use acetone, toluene and alcohol because they cause chemical damage to the polarizer.
- (8) Wipe off saliva or water drops as soon as possible. Their long time contact with polarizer causes deformations and color fading.
- (9) Do not open the case because inside circuits do not have sufficient strength.

9-2. Operating Precautions

- (1) The spike noise causes the mis-operation of circuits. It should be lower than following voltage :
 $V = \pm 200\text{mV}$ (Over and under shoot voltage)
- (2) Response time depends on the temperature. (In lower temperature, it becomes longer.)
- (3) Brightness depends on the temperature. (In lower temperature, it becomes lower.)
And in lower temperature, response time (required time that brightness is stable after turned on) becomes longer.
- (4) Be careful for condensation at sudden temperature change. Condensation makes damage to polarizer or electrical contacted parts. And after fading condensation, smear or spot will occur.
- (5) When fixed patterns are displayed for a long time, remnant image is likely to occur.
- (6) Module has high frequency circuits. Sufficient suppression to the electromagnetic interference shall be done by system manufacturers. Grounding and shielding methods may be important to minimize the interference.
- (7) Please do not give any mechanical and/or acoustical impact to LCM. Otherwise, LCM can't be operated its full characteristics perfectly.
- (8) A screw which is fastened up the steels should be a machine screw.
(if not, it causes metallic foreign material and deal LCM a fatal blow)
- (9) Please do not set LCD on its edge.

Product Specification

9-3. Electrostatic Discharge Control

Since a module is composed of electronic circuits, it is not strong to electrostatic discharge. Make certain that treatment persons are connected to ground through wrist band etc. And don't touch interface pin directly.

9-4. Precautions for Strong Light Exposure

Strong light exposure causes degradation of polarizer and color filter.

9-5. Storage

When storing modules as spares for a long time, the following precautions are necessary.

- (1) Store them in a dark place. Do not expose the module to sunlight or fluorescent light. Keep the temperature between 5°C and 35°C at normal humidity.
- (2) The polarizer surface should not come in contact with any other object.
It is recommended that they be stored in the container in which they were shipped.

9-6. Handling Precautions for Protection Film

- (1) The protection film is attached to the bezel with a small masking tape.
When the protection film is peeled off, static electricity is generated between the film and polarizer.
This should be peeled off slowly and carefully by people who are electrically grounded and with well ion-blown equipment or in such a condition, etc.
- (2) When the module with protection film attached is stored for a long time, sometimes there remains a very small amount of glue still on the bezel after the protection film is peeled off.
- (3) You can remove the glue easily. When the glue remains on the bezel surface or its vestige is recognized, please wipe them off with absorbent cotton waste or other soft material like chamois soaked with normal-hexane.

- The attached figure of the AI_ENABLE Circuit Block Diagram on the Control PCB ass'y

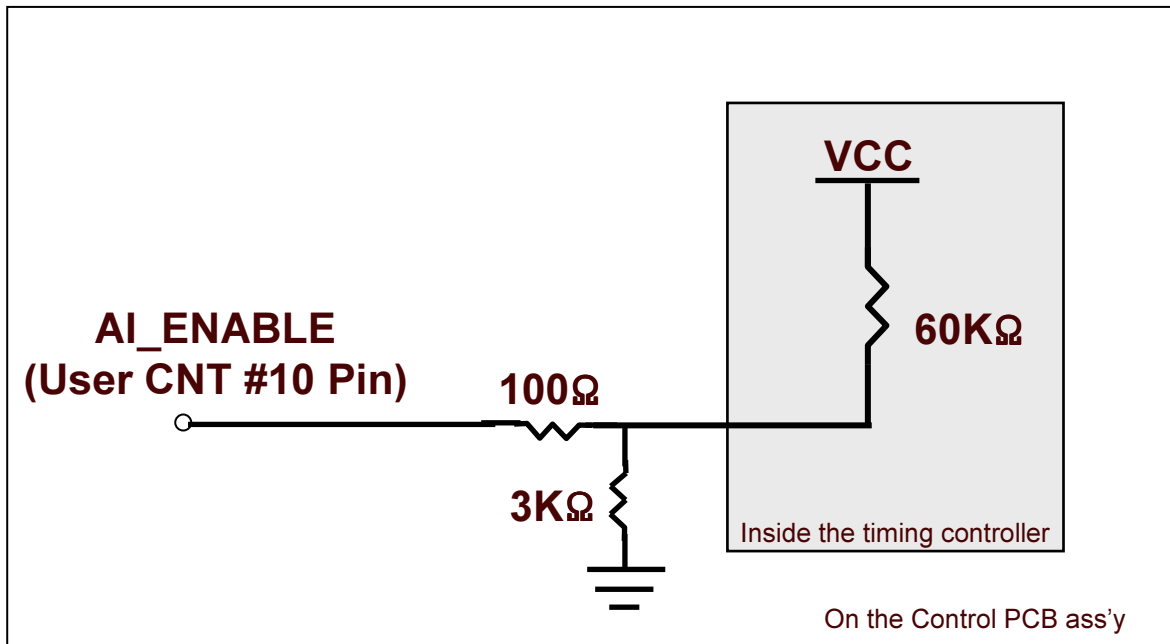
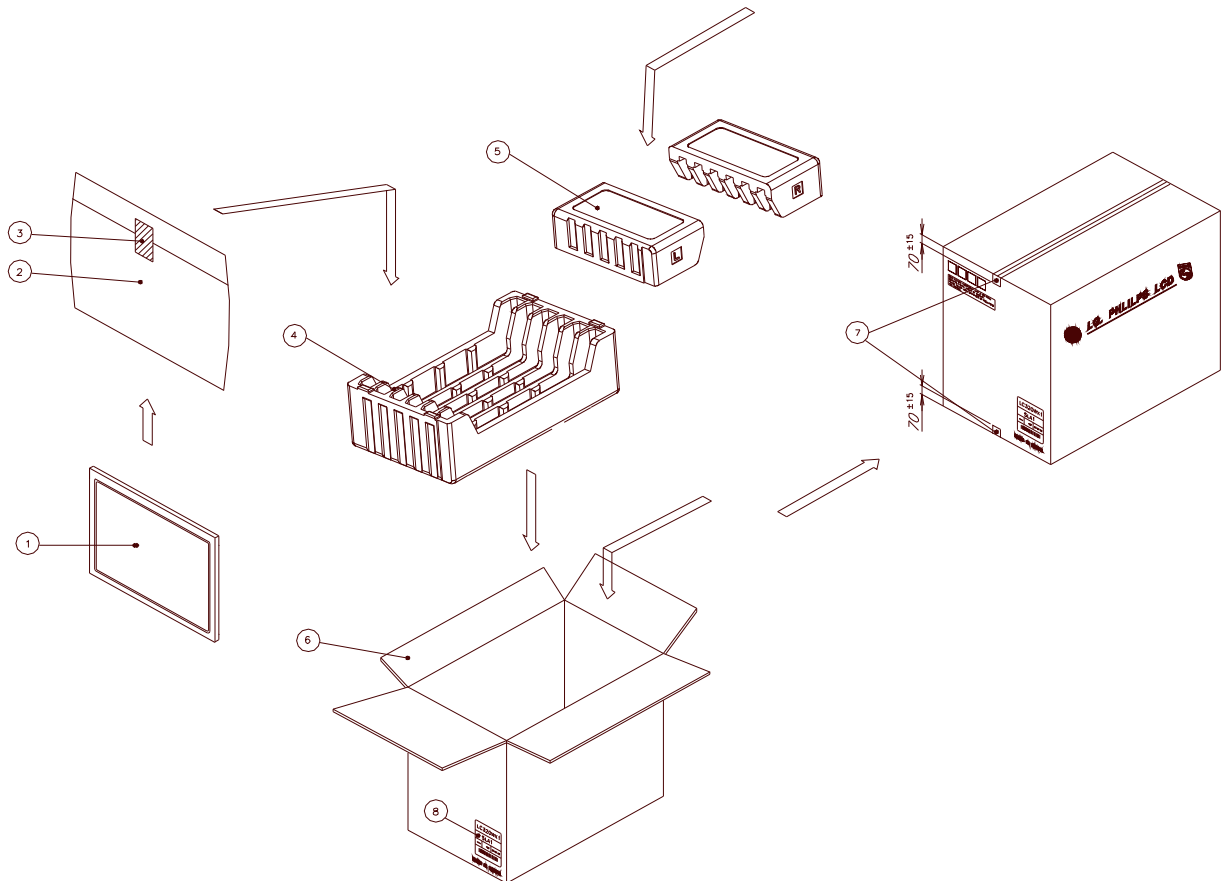

Fig. The AI ENABLE Circuit Block Diagram

Product Specification

APPENDIX- I

■ LC320W01—SL22 Packing Ass'y



NO.	DESCRIPTION	MATERIAL
1	LCD MODULE	
2	BAG	AL
3	TAPE	MASKING 20MM X 50M
4	PACKING, BOTTOM	EPS
5	PACKING, TOP R L	EPS
6	BOX	PAPER DW3
7	TAPE	OPP 70MMX300M
8	LABEL	YUPO PAPER 100X100

Product Specification

APPENDIX- II

■ LC320W01-SL22 Pallet Ass'y

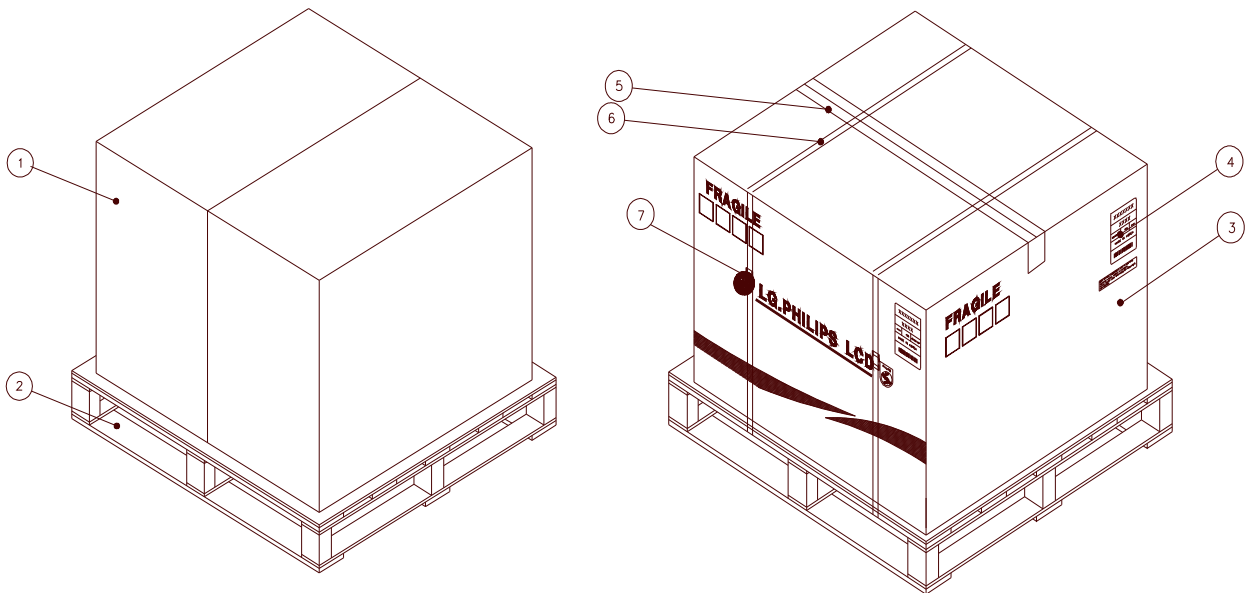

Box quantity per pallet: 2ea
 Pallet size: L1040 x W900 x H740
 Pallet gross weight: 113.0kg

NO.	DESCRIPTION	MATERIAL
1	PACKING ASS'Y	
2	PALLET	PAPER
3	AANGLE, PACKING	PAPER (DW3)
4	LABEL	PAPER
5	TAPE	OPP
6	BAND	PP
7	CLIP, BAND	STEEL

Product Specification

APPENDIX- III

■ LCM Label



■ Serial No. (See CAS 26page for more information)

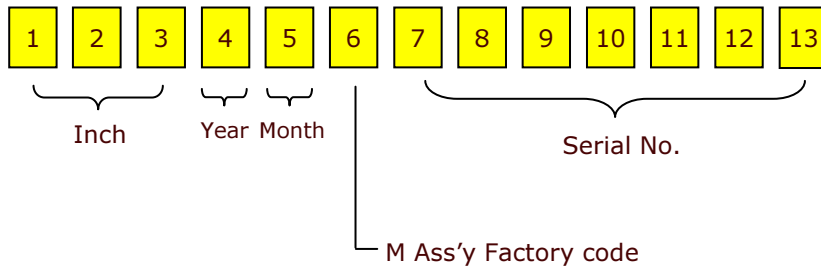

Product Specification

APPENDIX- IV

■ Box Label

■ Pallet Label

