



SmarterGlass

state-of-the-art display solutions

www.smarterglass.com
978 997 4104
sales@smarterglass.com

Product Specification

SPECIFICATION FOR APPROVAL

- () Preliminary Specification
- (●) Final Specification

Title	42.0" WUXGA TFT LCD
-------	---------------------

BUYER			
MODEL			

SUPPLIER	LG.Philips LCD Co., Ltd.
*MODEL	LC420WUN
SUFFIX	SAA1 (RoHS verified)

*When you obtain standard approval, please use the above model name without suffix

APPROVED BY	SIGNATURE DATE
/	_____
/	_____
/	_____

APPROVED BY	SIGNATURE DATE
H.S. Baek / Senior Manager	_____
REVIEWED BY	
S.Y. Paik / Manager	_____
PREPARED BY	
J.B. Chun / Engineer	_____

Please return 1 copy for your confirmation with your signature and comments.

**TV Product Development Dept.
LG. Philips LCD Co., Ltd**

Product Specification

CONTENTS

Number	ITEM	Page
	COVER	1
	CONTENTS	2
	RECORD OF REVISIONS	3
1	GENERAL DESCRIPTION	4
2	ABSOLUTE MAXIMUM RATINGS	5
3	ELECTRICAL SPECIFICATIONS	6
3-1	ELECTRICAL CHARACTERISTICS	6
3-2	INTERFACE CONNECTIONS	8
3-3	SIGNAL TIMING SPECIFICATIONS	10
3-4	SIGNAL TIMING WAVEFORMS	11
3-5	COLOR DATA REFERENCE	12
3-6	POWER SEQUENCE	13
4	OPTICAL SPECIFICATIONS	15
5	MECHANICAL CHARACTERISTICS	19
6	RELIABILITY	22
7	INTERNATIONAL STANDARDS	23
7-1	SAFETY	23
7-2	EMC	23
8	PACKING	24
8-1	DESIGNATION OF LOT MARK	24
8-2	PACKING FORM	24
9	PRECAUTIONS	25
9-1	MOUNTING PRECAUTIONS	25
9-2	OPERATING PRECAUTIONS	25
9-3	ELECTROSTATIC DISCHARGE CONTROL	26
9-4	PRECAUTIONS FOR STRONG LIGHT EXPOSURE	26
9-5	STORAGE	26
9-6	HANDLING PRECAUTIONS FOR PROTECTION FILM	26
Appendix		27~33

Product Specification

1. General Description

LC420WUN is a Color Active Matrix Liquid Crystal Display with an integral External Electrode Fluorescent Lamp(EEFL) backlight system. The matrix employs a-Si Thin Film Transistor as the active element. It is a transmissive type display operating in the normally black mode. It has a 42 inch diagonally measured active display area with WUXGA resolution (1080 vertical by 1920 horizontal pixel array) Each pixel is divided into Red, Green and Blue sub-pixels or dots which are arranged in vertical stripes. Gray scale or the luminance of the sub-pixel color is determined with a 8bit or 10-bit gray scale signal for each dot, thus presenting a palette of more than 1.06Billion of colors. It has been designed to apply the 10-bit 2 port LVDS interface. It is intended to support LCD TV, PCTV where high brightness, super wide viewing angle, high color gamut, high color depth and fast moving picture response time are important.

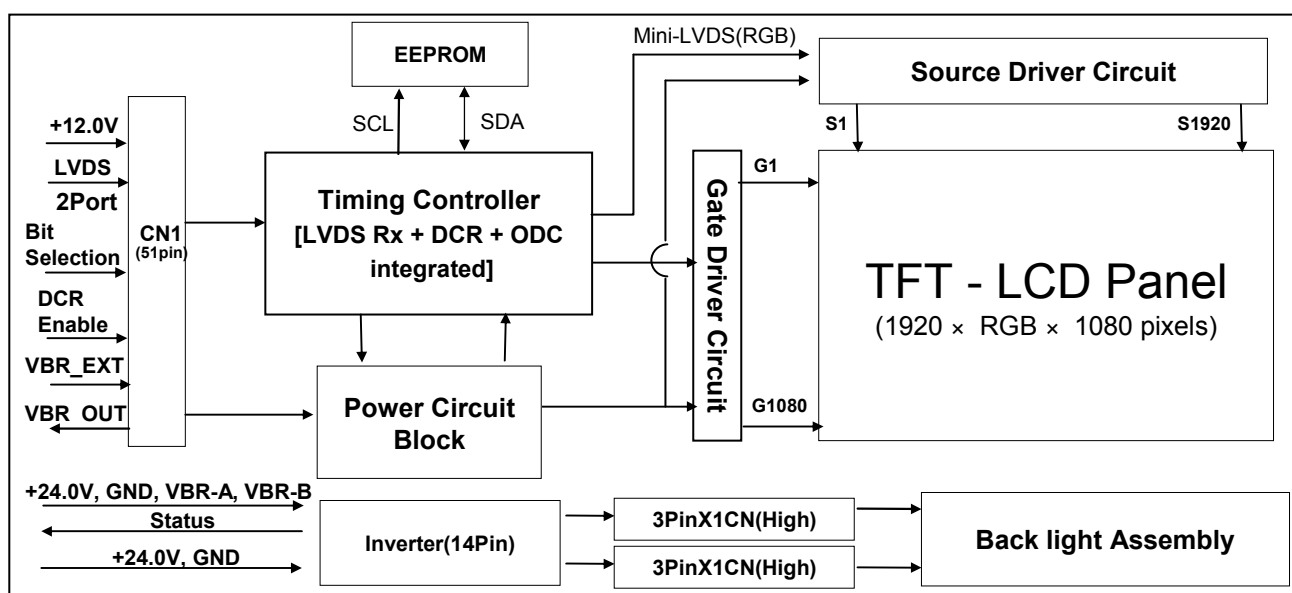

General Features

Active Screen Size	42.02 inches(1067.31mm) diagonal
Outline Dimension	983.0(H) x 576.0 (V) x 51.0 mm(D) (Typ.)
Pixel Pitch	0.4845 mm x 0.4845 mm
Pixel Format	1920 horiz. by 1080 vert. Pixels, RGB stripe arrangement
Color Depth	10bit (D), 1.06Billion colors
Luminance, White	500 cd/m ² (Center 1point ,Typ.)
Viewing Angle (CR>10)	Viewing angle free (R/L 178 (Typ.), U/D 178 (Typ.))
Power Consumption	Total 167.5 W (Typ.) (Logic = 6.7 W, Inverter = 160.8 W [VBR-A=1.65V])
Weight	11.5Kg (Typ.)
Display Mode	Transmissive mode, Normally black
Surface Treatment	Hard coating(3H), Anti-glare treatment of the front polarizer (Haze 13%)

Product Specification

2. Absolute Maximum Ratings

The following items are maximum values which, if exceeded, may cause faulty operation or damage to the LCD module.

Table 1. ABSOLUTE MAXIMUM RATINGS

Parameter		Symbol	Value		Unit	Remark
			Min	Max		
Power Input Voltage	LCM	V _{LCD}	-0.3	+14.0	V _{DC}	at 25 ± 2 °C
	Backlight inverter	V _{BL}	-0.3	+27.0	V _{DC}	
ON/OFF Control Voltage		V _{ON/OFF}	-0.3	+5.5	V _{DC}	
Brightness Control Voltage		V _{BR}	0	+5.0	V _{DC}	
Operating Temperature		T _{OP}	0	+50	°C	Note 1,2
Storage Temperature		T _{ST}	-20	+60	°C	
Operating Ambient Humidity		H _{OP}	10	90	%RH	
Storage Humidity		H _{ST}	10	90	%RH	

- Notes : 1. Temperature and relative humidity range are shown in the figure below.
Wet bulb temperature should be 39 °C Max, and no condensation.
2. Gravity mura can be guaranteed under 40 °C condition.

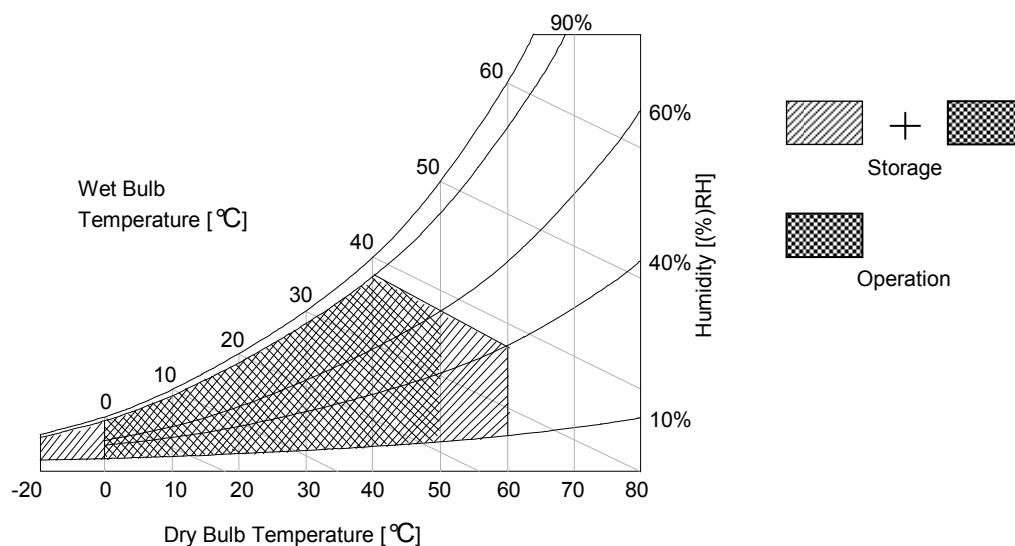

Product Specification

3. Electrical Specifications

3-1. Electrical Characteristics

It requires two power inputs. One is employed to power for the LCD circuit. The other is used for the EEFL backlight and inverter circuit.

Table 2. ELECTRICAL CHARACTERISTICS

Parameter	Symbol	Value			Unit	Note
		Min	Typ	Max		
Circuit :						
Power Input Voltage	V _{LCD}	11.4	12.0	12.6	V _{DC}	
Power Input Current	I _{LCD}	-	560	728	mA	1
		-	800	1040	mA	2
Power Consumption	P _{LCD}	-	6.7	8.8	Watt	1
Rush current	I _{RUSH}	-	-	3	A	3

- Notes :
1. The specified current and power consumption are under the $V_{LCD}=12.0V$, $25 \pm 2^{\circ}C$, $f_V=60Hz$ condition whereas mosaic pattern(8 x 6) is displayed and f_V is the frame frequency.
 2. The current is specified at the maximum current pattern.
 3. The duration of rush current is about 2ms and rising time of power input is 0.5ms (min)

White : 1023Gray
Black : 0Gray

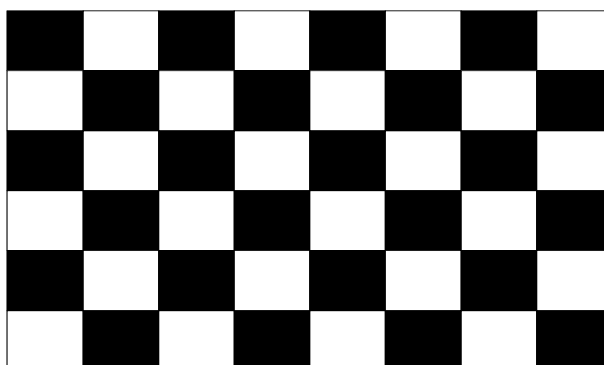

Mosaic Pattern(8 x 6)

Product Specification

Table 3. ELECTRICAL CHARACTERISTICS (Continue)

Parameter		Symbol	Values			Unit	Notes	
			Min	Typ	Max			
Inverter :								
Power Supply Input Voltage		VBL	22.8	24.0	25.2	Vdc	1	
Power Supply Input Voltage Ripple			-	-	0.5	Vp-p	1	
Power Supply Input Current	After Aging	IBL_A	-	6.7	7.2	A	$V_{BR-A} = 1.65V \dots 1$	
			-	7.2	7.7	A	$V_{BR-A} = 3.3V \dots 1$	
	Before Aging	IBL_B	-	7.5	8.0	A	$V_{BR-A} = 1.65V \dots 2$	
			-	8.0	8.5	A	$V_{BR-A} = 3.3V \dots 2$	
Power Supply Input Current (In-Rush)		Irush	-	-	11	A	$V_{BL} = 22.8V$ $V_{BR-B} = 3.3V$ $V_{BR-A} = 1.65V$	
Power Consumption		PBL	-	160.8	172.8	W	$V_{BR-A} = 1.65V \dots 1$	
Input Voltage for Control System Signals	Brightness Adjust		V_{BR-A}	0.0	1.65	3.3	Vdc	
	On/Off	On	V on	2.5	-	5.0	Vdc	
		Off	V off	-0.3	0.0	0.8	Vdc	
	Brightness Adjust		V_{BR-B}	0	-	3.3	V	
Lamp:								
Discharge Stabilization Time		Ts			3	min	3	
Life Time			50,000			Hrs	4	

Notes :

- Electrical characteristics are determined after the unit has been 'ON' and stable for approximately 120 minutes at $25 \pm 2^\circ\text{C}$. The specified current and power consumption are under the typical supply Input voltage 24V and V_{BR} ($V_{BR-A} : 1.65V$ & $V_{BR-B} : 3.3V$), it is total power consumption. The ripple voltage of the power supply input voltage is under 0.5 Vp-p. LPL recommend Input Voltage is $24.0V \pm 5\%$.
- Electrical characteristics are determined within 30 minutes at $25 \pm 2^\circ\text{C}$. The specified currents are under the typical supply Input voltage 24V.
- The brightness of the lamp after lighted for 5minutes is defined as 100%. TS is the time required for the brightness of the center of the lamp to be not less than 95% at typical current. The screen of LCD module may be partially dark by the time the brightness of lamp is stable after turn on.
- Specified Values are for a single lamp which is aligned horizontally. The life time is determined as the time which luminance of the lamp is 50% compared to that of initial value at the typical lamp current ($V_{BR-A} : 1.65V$ & $V_{BR-B} : 3.3V$), on condition of continuous operating at $25 \pm 2^\circ\text{C}$
- The duration of rush current is about 10 ms.

Product Specification

3-2. Interface Connections

This LCD module employs two kinds of interface connection, a 51-pin connector is used for the module electronics and a 14-pin connector is used for the integral backlight system.

3-2-1. LCD Module

- LCD Connector(CN1): FI-RE51S-HF(manufactured by JAE) or KN25-51P-0.5SH(manufactured by Hirose)
- Mating Connector : FI-R51HL(JAE) or compatible

Table 4. MODULE CONNECTOR(CN1) PIN CONFIGURATION

No	Symbol	Description	No	Symbol	Description
1	GND	Ground	27	Bit Selection	'L'=8bit,'H'=10bit (D)
2	NC	No Connection	28	RE0N	SECOND CHANNEL 0-
3	NC	No Connection	29	RE0P	SECOND CHANNEL 0+
4	NC	No Connection	30	RE1N	SECOND CHANNEL 1-
5	NC	No Connection	31	RE1P	SECOND CHANNEL 1+
6	NC	No Connection	32	RE2N	SECOND CHANNEL 2-
7	LVDS Select	'H' =JEIDA , 'L' = VESA	33	RE2P	SECOND CHANNEL 2+
8	VBR_EXT	External VBR	34	GND	Ground
9	VBR_OUT	VBR output	35	RECLKN	SECOND CLOCK CHANNEL C-
10	DCR_Enable	'H' = Enable , 'L' = Disable	36	RECLKP	SECOND CLOCK CHANNEL C+
11	GND	Ground	37	GND	Ground
12	RO0N	FIRST CHANNEL 0-	38	RE3N	SECOND CHANNEL 3-
13	RO0P	FIRST CHANNEL 0+	39	RE3P	SECOND CHANNEL 3+
14	RO1N	FIRST CHANNEL 1-	40	RE4N	SECOND CHANNEL 4- (For 10bit D)
15	RO1P	FIRST CHANNEL 1+	41	RE4P	SECOND CHANNEL 4+ (For 10bit D)
16	RO2N	FIRST CHANNEL 2-	42	Reserved	No connection or GND
17	RO2P	FIRST CHANNEL 2+	43	Reserved	No connection or GND
18	GND	Ground	44	GND	Ground
19	ROCLKN	FIRST CLOCK CHANNEL C-	45	GND	Ground
20	ROCLKP	FIRST CLOCK CHANNEL C+	46	GND	Ground
21	GND	Ground	47	NC	No connection
22	RO3N	FIRST CHANNEL 3-	48	VLCD	Power Supply +12.0V
23	RO3P	FIRST CHANNEL 3+	49	VLCD	Power Supply +12.0V
24	RO4N	FIRST CHANNEL 4- (For 10bit D)	50	VLCD	Power Supply +12.0V
25	RO4P	FIRST CHANNEL 4+ (For 10bit D)	51	VLCD	Power Supply +12.0V
26	Reserved	No connection or GND	-	-	-

- Notes :
1. All GND(ground) pins should be connected together to the LCD module's metal frame.
 2. All VLCD (power input) pins should be connected together.
 3. All Input levels of LVDS signals are based on the EIA 664 Standard.
 4. Specific pins(pin No. #2~#6) are used for internal data process of the LCD module.
If not used, these pins are no connection.
 5. Specific pins(pin No. #8~#9) are used for Inverter test of the LCD module.
If not used, these pins are no connection.
 6. Specific pin No. #44 is used for "No signal detection" of system signal interface.
It should be GND for NSB(No Signal Black) during the system interface signal is not.
If this pin is "H", LCD Module displays AGP(Auto Generation Pattern).

Product Specification

3-2-2. Backlight Inverter

Inverter Connector : S14B-PH-SMC

(manufactured by JST) or Equivalent

- Mating Connector : PHR-14 or Equivalent

Table 5. INVERTER CONNECTOR PIN CONFIGURATION

Pin No	Symbol	Description	Inv.	Note
1	VBL	Power Supply +24.0V	VBL	
2	VBL	Power Supply +24.0V	VBL	
3	VBL	Power Supply +24.0V	VBL	
4	VBL	Power Supply +24.0V	VBL	
5	VBL	Power Supply +24.0V	VBL	
6	GND	Backlight Ground	GND	1
7	GND	Backlight Ground	GND	
8	GND	Backlight Ground	GND	
9	GND	Backlight Ground	GND	
10	GND	Backlight Ground	GND	
11	VBR-A	Analog dimming voltage DC 0.0V ~ 3.3V (Typ : 1.65V)	VBR-A	2, 3
12	VON/OFF	0.0V ~ 5.0V	On/Off	
13	VBR-B	Burst dimming voltage DC 0.0V ~ 3.3V	VBR-B	3
14	Status	Normal : Upper 3.0V Abnormal : Under 0.7V	Status	4

Notes : 1. GND should be connected to the LCD module's metal frame.

2. If Pin #11 is open, VBR-A = 1.65V. When apply over 1.65V (~ 3.3V) continuously, its luminance is increasing however lamp's life time is decreasing.

It could be usable for boost up luminance when using DCR (=Dynamic contrast ratio) function only.

3. Minimum Brightness : VBR-B = 0V Maximum Brightness : VBR-B = 3.3V

4. Even though Pin #14 is open, there is no effect on inverter operating, the output terminal of inverter.

5. Each impedance of pin #11,12 and 13 is 240[KΩ], 80[KΩ], 160[KΩ]

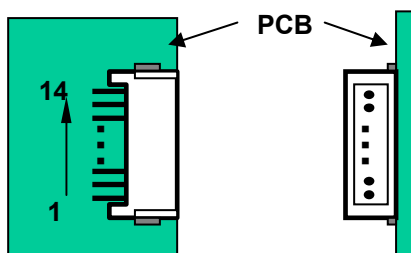
◆ Rear view of LCM

Product Specification

3-3. Signal Timing Specifications

Table 6 shows the signal timing required at the input of the LVDS transmitter. All of the interface signal timing should be satisfied with the following specification for normal operation.

Table 6. TIMING TABLE for NTSC (DE Only Mode)

ITEM		Symbol	Min	Typ	Max	Unit	Note
Horizontal	Display Period	t _{HV}	-	960	-	tclk	
	Blank	t _{HB}	100	140	240	tclk	
	Total	t _{HP}	1060	1100	1200	tclk	2200/2
Vertical	Display Period	t _{VV}	-	1080	-	Lines	
	Blank	t _{VB}	11	45	69	Lines	
	Total	t _{VP}	1091	1125	1149	Lines	

ITEM		Symbol	Min	Typ	Max	Unit	Note
Frequency	DCLK	f _{CLK}	70	74.25	77	MHz	148.5/2
	Horizontal	f _H	65.5	67.5	68.9	KHz	
	Vertical	f _V	57	60	63	Hz	

Table 7 shows the signal timing required at the input of the LVDS transmitter. All of the interface signal timing should be satisfied with the following specification for normal operation.

Table 7. TIMING TABLE for PAL (DE Only Mode)

ITEM		Symbol	Min	Typ	Max	Unit	Note
Horizontal	Display Period	t _{HV}	-	960	-	tclk	
	Blank	t _{HB}	100	140	240	tclk	
	Total	t _{HP}	1060	1100	1200	tclk	2200/2
Vertical	Display Period	t _{VV}	-	1080	-	Lines	
	Blank	t _{VB}	228	270	300	Lines	
	Total	t _{VP}	1308	1350	1380	Lines	

ITEM		Symbol	Min	Typ	Max	Unit	Note
Frequency	DCLK	f _{CLK}	70	74.25	77	MHz	148.5/2
	Horizontal	f _H	65.5	67.5	68.9	KHz	
	Vertical	f _V	47	50	53	Hz	

Note : The Input of HSYNC & VSYNC signal does not have an effect on normal operation(DE Only Mode).
The performance of the electro-optical characteristics may be influenced by variance of the vertical refresh rate.

Product Specification

3-4. Signal Timing Waveforms

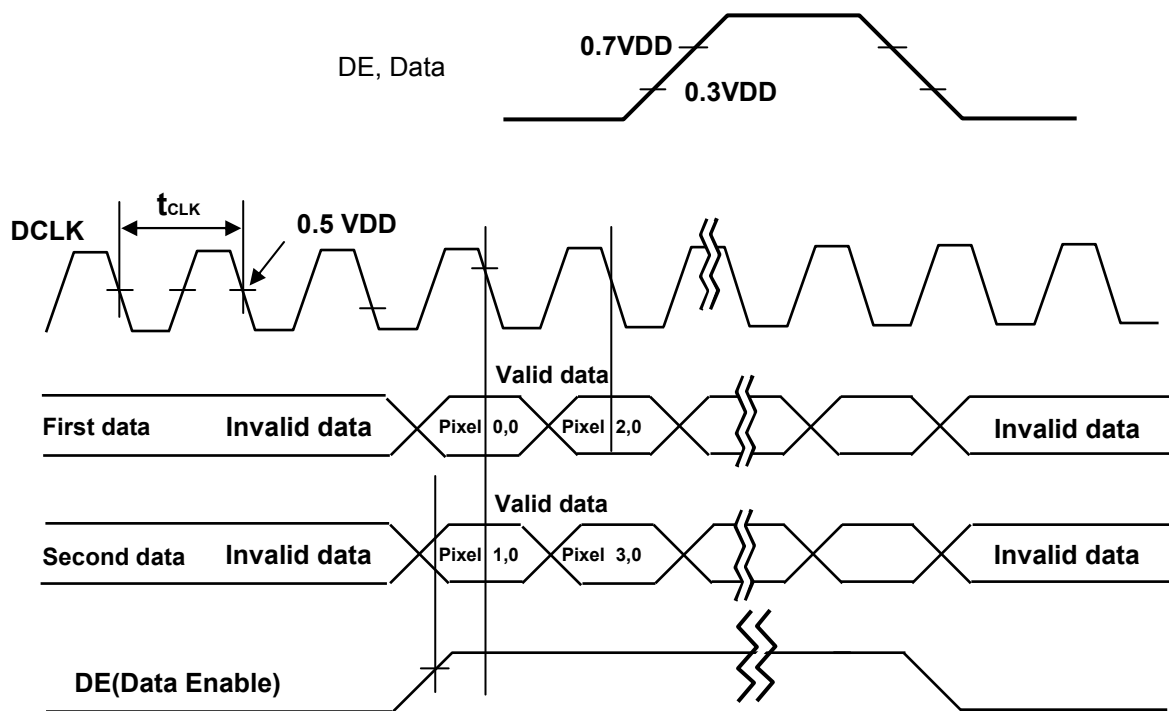

* Reference : Sync. Relation

* $t_{HB} = t_{HFP} + t_{WH} + t_{HBP}$

* $t_{VB} = t_{VFP} + t_{WV} + t_{VBP}$

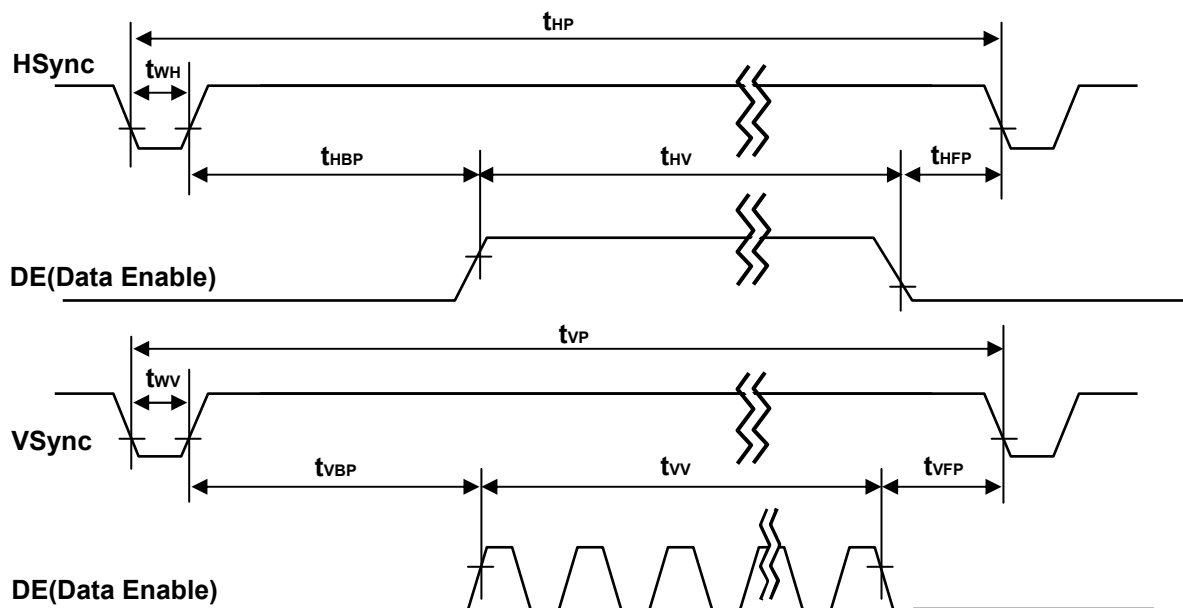

Product Specification

3-5. Color Data Reference

The brightness of each primary color(red,green,blue) is based on the 10bit(D) gray scale data input for the color. The higher binary input, the brighter the color. Table 8 provides a reference for color versus data input.

Table 8. COLOR DATA REFERENCE

Color		Input Color Data																													
		RED										GREEN										BLUE									
		MSB					LSB					MSB					LSB					MSB					LSB				
		R9	R8	R7	R6	R5	R4	R3	R2	R1	R0	G9	G8	G7	G6	G5	G4	G3	G2	G1	G0	B9	B8	B7	B6	B5	B4	B3	B2	B1	B0
Basic Color	Black	0	0	0	0	0	0	0	0	0	0	0	0	0	0	0	0	0	0	0	0	0	0	0	0	0	0	0	0	0	0
	Red (1023)	1	1	1	1	1	1	1	1	1	1	0	0	0	0	0	0	0	0	0	0	0	0	0	0	0	0	0	0	0	0
	Green (1023)	0	0	0	0	0	0	0	0	0	0	1	1	1	1	1	1	1	1	1	1	0	0	0	0	0	0	0	0	0	0
	Blue (1023)	0	0	0	0	0	0	0	0	0	0	0	0	0	0	0	0	0	0	0	0	1	1	1	1	1	1	1	1	1	1
	Cyan	0	0	0	0	0	0	0	0	0	0	1	1	1	1	1	1	1	1	1	1	1	1	1	1	1	1	1	1	1	1
	Magenta	1	1	1	1	1	1	1	1	1	1	0	0	0	0	0	0	0	0	0	0	1	1	1	1	1	1	1	1	1	1
	Yellow	1	1	1	1	1	1	1	1	1	1	1	1	1	1	1	1	1	1	1	1	0	0	0	0	0	0	0	0	0	0
	White	1	1	1	1	1	1	1	1	1	1	1	1	1	1	1	1	1	1	1	1	1	1	1	1	1	1	1	1	1	1
RED	RED (000)	0	0	0	0	0	0	0	0	0	0	0	0	0	0	0	0	0	0	0	0	0	0	0	0	0	0	0	0	0	
	RED (001)	0	0	0	0	0	0	0	0	0	0	0	0	0	0	0	0	0	0	0	0	0	0	0	0	0	0	0	0	0	
		
	RED (1022)	1	1	1	1	1	1	1	1	1	0	0	0	0	0	0	0	0	0	0	0	0	0	0	0	0	0	0	0	0	
	RED (1023)	1	1	1	1	1	1	1	1	1	0	0	0	0	0	0	0	0	0	0	0	0	0	0	0	0	0	0	0	0	
GREEN	GREEN (000)	0	0	0	0	0	0	0	0	0	0	0	0	0	0	0	0	0	0	0	0	0	0	0	0	0	0	0	0	0	
	GREEN (001)	0	0	0	0	0	0	0	0	0	0	0	0	0	0	0	0	0	0	0	0	0	0	0	0	0	0	0	0	0	
		
	GREEN (1022)	0	0	0	0	0	0	0	0	0	1	1	1	1	1	1	1	1	1	1	0	0	0	0	0	0	0	0	0	0	
	GREEN (1023)	0	0	0	0	0	0	0	0	0	1	1	1	1	1	1	1	1	1	1	0	0	0	0	0	0	0	0	0	0	
BLUE	BLUE (000)	0	0	0	0	0	0	0	0	0	0	0	0	0	0	0	0	0	0	0	0	0	0	0	0	0	0	0	0	0	
	BLUE (001)	0	0	0	0	0	0	0	0	0	0	0	0	0	0	0	0	0	0	0	0	0	0	0	0	0	0	0	0	0	
		
	BLUE (1022)	0	0	0	0	0	0	0	0	0	0	0	0	0	0	0	0	0	0	0	1	1	1	1	1	1	1	1	1	0	
	BLUE (1023)	0	0	0	0	0	0	0	0	0	0	0	0	0	0	0	0	0	0	0	1	1	1	1	1	1	1	1	1	1	

Product Specification

3-6. Power Sequence

3-6-1. LCD Driving circuit

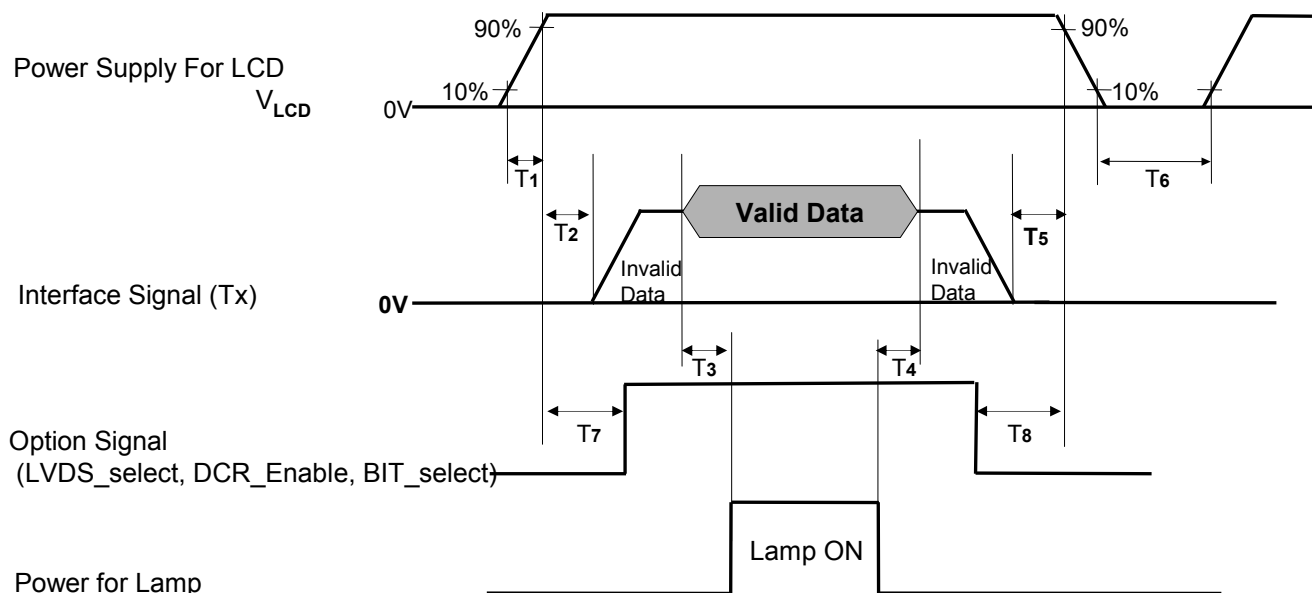

Table 9. POWER SEQUENCE

Parameter	Value			Unit	Notes
	Min	Typ	Max		
T1	0.5	-	20	ms	
T2	0	-	-	ms	4
T3	200	-	-	ms	3
T4	200	-	-	ms	3
T5	0	-	-	ms	
T6	2.0	-	-	s	5
T7	0	-	T2	ms	4
T8	0	-	-	ms	4

- Note :
1. Please avoid floating state of interface signal at invalid period.
 2. When the interface signal is invalid, be sure to pull down the power supply V_{LCD} to 0V.
 3. The T3/T4 is recommended value, the case when failed to meet a minimum specification, abnormal display would be shown. There is no reliability problem.
 4. If the on time of signals (Interface signal and Option signals) precedes the on time of Power (V_{LCD}), check the LCD logic Power (V_{CC}) is under 0.8V, otherwise it will be happened abnormal display.
 5. T6 should be measured after the Module has been fully discharged between power off and on period.

Product Specification

3-6-2. Sequence for Inverter

Power Supply For Inverter

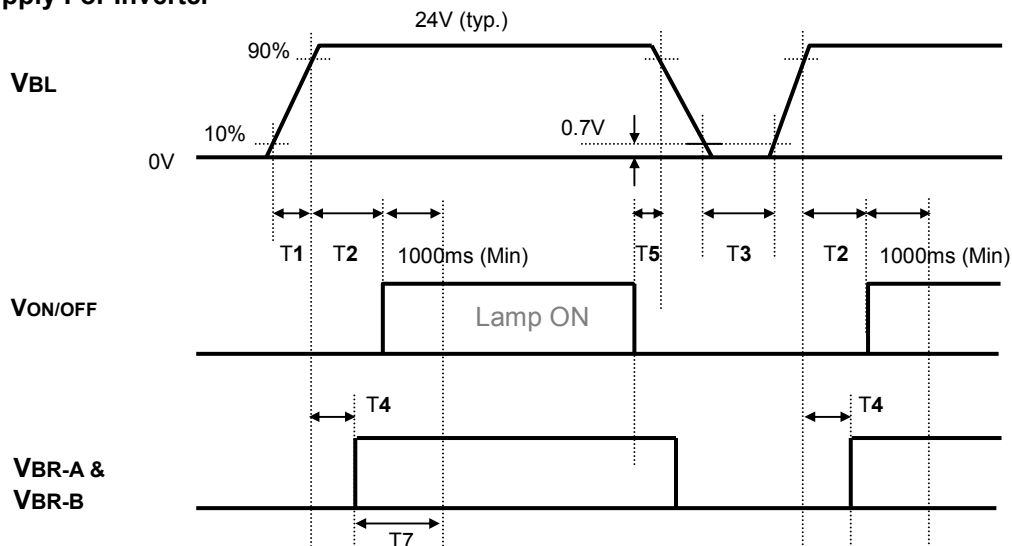

3-6-3. Deep condition for Inverter

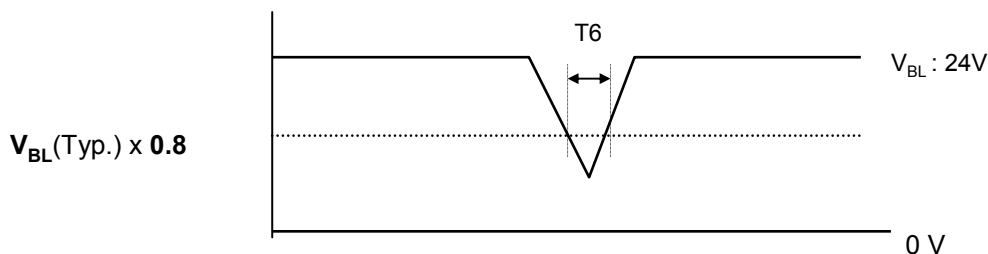

Table 10. Power Sequence for Inverter

Parameter	Values			Units	Remarks
	Min	Typ	Max		
T1	20	-	-	ms	1
T2	500	-	-	ms	
T3	200	-	-	ms	
T4	0	-	-	ms	2
T5	10	-	-	ms	
T6	-	-	10	ms	$V_{BL}(Typ) \times 0.8$
T7	1000	-	-	ms	3

- Notes :
1. T1 describes rising time of 0V to 24V and this parameter does not applied at restarting time.
 2. T4(max) is less than T2.
 3. In T7 section, V_{BR-B} is recommended 3.3V & $V_{BR-A} = 1.65V$.

Product Specification

4. Optical Specification

Optical characteristics are determined after the unit has been 'ON' and stable in a dark environment at $25 \pm 2^\circ\text{C}$. The values specified are at an approximate distance 50cm from the LCD surface at a viewing angle of Φ and θ equal to 0° .

FIG. 1 shows additional information concerning the measurement equipment and method.

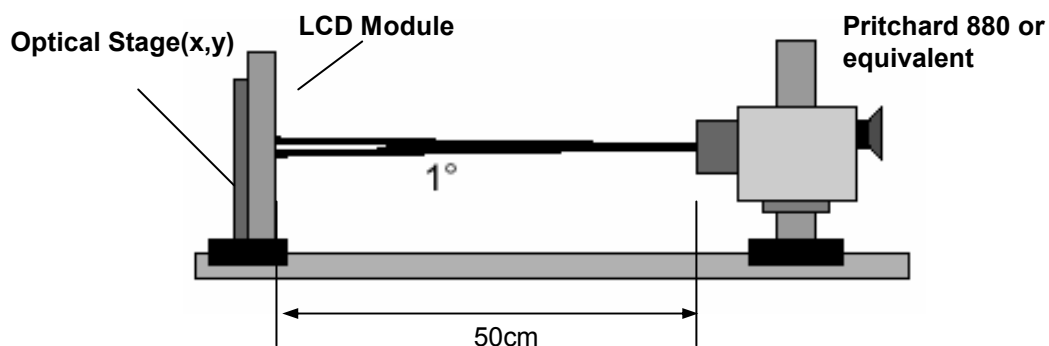

FIG. 1 Optical Characteristic Measurement Equipment and Method

Table 11. OPTICAL CHARACTERISTICS

$T_a = 25 \pm 2^\circ\text{C}$, $V_{LCD} = 12.0\text{V}$, $f_v = 60\text{Hz}$, $D_{clk} = 148.5\text{MHz}$, $V_{BR_A} = 1.65\text{V}$, $V_{BR_B} = 3.3\text{V}$

Parameter	Symbol	Value			Unit	Note	
		Min	Typ	Max			
Contrast Ratio	CR	900	1300	-		1	
Surface Luminance, white	L_{WH}	400	500	-	cd/m ²	2	
Luminance Variation	δ_{WHITE} 5P	-	-	1.3		3	
Response Time	Gray-to-Gray	G to G	-	5	8	ms	4,5
Color Coordinates [CIE1931]	RED	Rx	Typ -0.03	0.640	Typ +0.03		
		Ry		0.335			
	GREEN	Gx		0.289			
		Gy		0.610			
	BLUE	Bx		0.144			
		By		0.066			
	WHITE	Wx		0.279			
		Wy		0.292			
Viewing Angle (CR>10)							
	x axis, right($\phi=0^\circ$)	θ_r	89	-	-	degree	6
	x axis, left ($\phi=180^\circ$)	θ_l	89	-	-		
	y axis, up ($\phi=90^\circ$)	θ_u	89	-	-		
	y axis, down ($\phi=270^\circ$)	θ_d	89	-	-		
Gray Scale			-	-	-		7

Product Specification

Notes :1. Contrast Ratio(CR) is defined mathematically as :

CR(Contrast Ratio) = Maximum CR_n (n=1, 2, 3, 4, 5)

$$CR_n = \frac{\text{Surface Luminance at position n with all white pixels}}{\text{Surface Luminance at position n with all black pixels}}$$

n = the Position number(1, 2, 3, 4, 5). For more information, see FIG. 2.

※ DCR Application : Refer to Appendix V

2. Surface luminance are determined after the unit has been 'ON' and 30min after lighting the backlight in a dark environment at 25± 2°C. Surface luminance is the luminance value at center 1-point across the LCD surface 50cm from the surface with all pixels displaying white. For more information see the FIG. 2.

3. The variation in surface luminance , δ WHITE is defined as :

$$\delta \text{ WHITE}(5P) = \text{Maximum}(L_{on1}, L_{on2}, L_{on3}, L_{on4}, L_{on5}) / \text{Minimum}(L_{on1}, L_{on2}, L_{on3}, L_{on4}, L_{on5})$$

Where L_{on1} to L_{on5} are the luminance with all pixels displaying white at 5 locations .

For more information, see the FIG. 2.

4. Response time is the time required for the display to transition from G(N) to G(M) (Rise Time, Tr_R) and from G(M) to G(N) (Decay Time, Tr_D). For additional information see the FIG. 3. (N<M)

※ G to G Spec is average of measured time.

5. Viewing angle is the angle at which the contrast ratio is greater than 10. The angles are determined for the horizontal or x axis and the vertical or y axis with respect to the z axis which is normal to the LCD module surface. For more information, see the FIG. 4.

6. Gray scale specification

Gamma Value is approximately 2.2. For more information, see the Table 12.

Table 12. GRAY SCALE SPECIFICATION

Gray Level	Luminance [%] (Typ.)
L0	0.08
L63	0.21
L127	0.86
L191	2.32
L255	4.71
L319	7.70
L383	11.52
L447	16.18
L511	21.72
L575	28.15
L639	35.51
L703	43.81
L767	53.07
L831	63.30
L895	74.52
L959	86.75
L1023	100

Product Specification

Measuring point for surface luminance & measuring point for luminance variation.

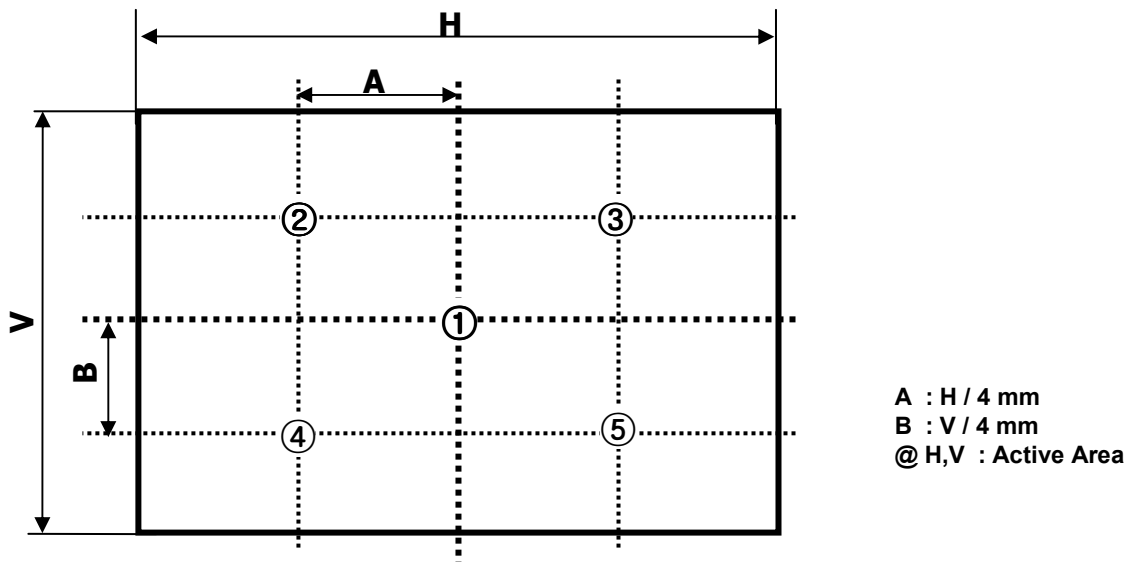

FIG. 2 5 Points for Luminance Measure

Response time is defined as the following figure and shall be measured by switching the input signal for "Gray(N)" and "Gray(M)".

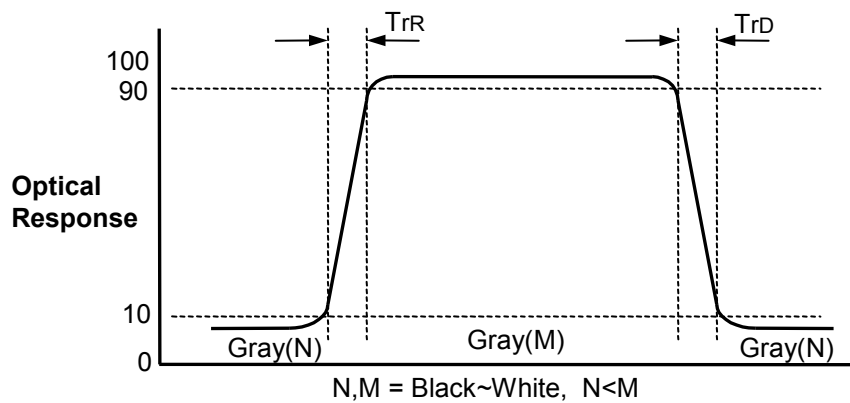

FIG. 3 Response Time

Product Specification

Dimension of viewing angle range

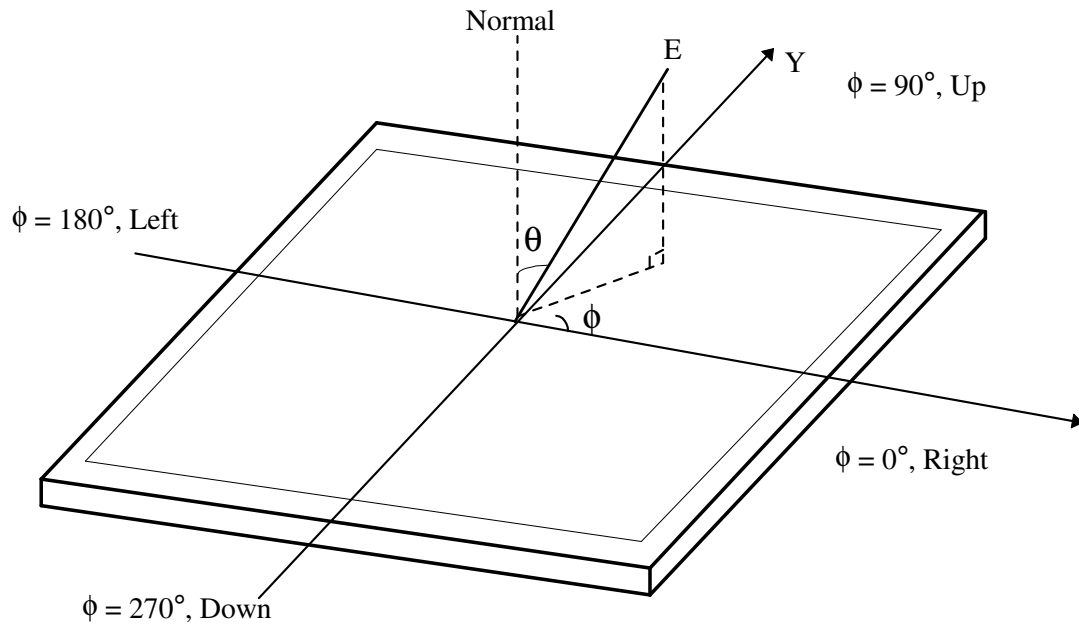

FIG. 4 Viewing Angle

5. Mechanical Characteristics

Table 13 provides general mechanical characteristics.

Table 13. MECHANICAL CHARACTERISTICS

Item	Value	
Outline Dimension	Horizontal	983.0 mm
	Vertical	576.0 mm
	Depth	51.0 mm
Bezel Area	Horizontal	939.0 mm
	Vertical	531.0 mm
Active Display Area	Horizontal	930.24 mm
	Vertical	523.26 mm
Weight	11.5 Kg (Typ.) , 12.5Kg (Max.)	

Note : Please refer to a mechanic drawing in terms of tolerance at the next page.

Product Specification

<FRONT VIEW>

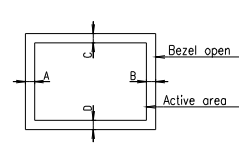
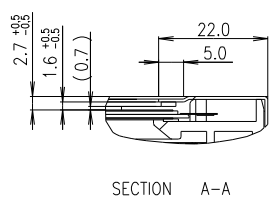
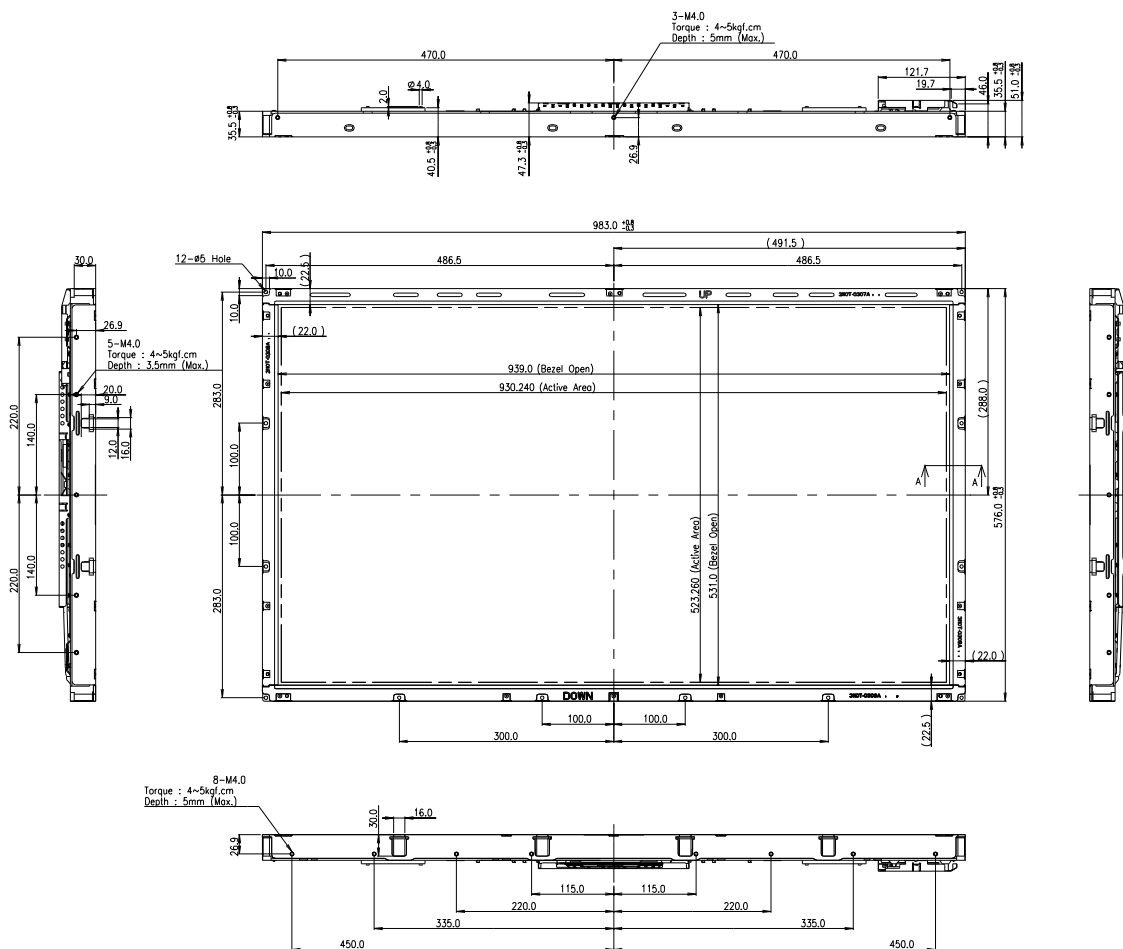

- NOTES
1. Unspecified tolerances are to be ±1.0mm.
 2. Tilt and partial disposition tolerance of display area are as following:
 - (1) X-Direction : |A-B| ≤ 1.5mm
 - (2) Y-Direction : |C-D| ≤ 1.5mm

Product Specification

<REAR VIEW>

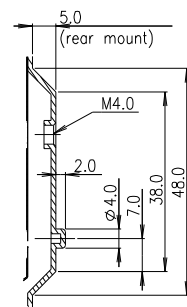
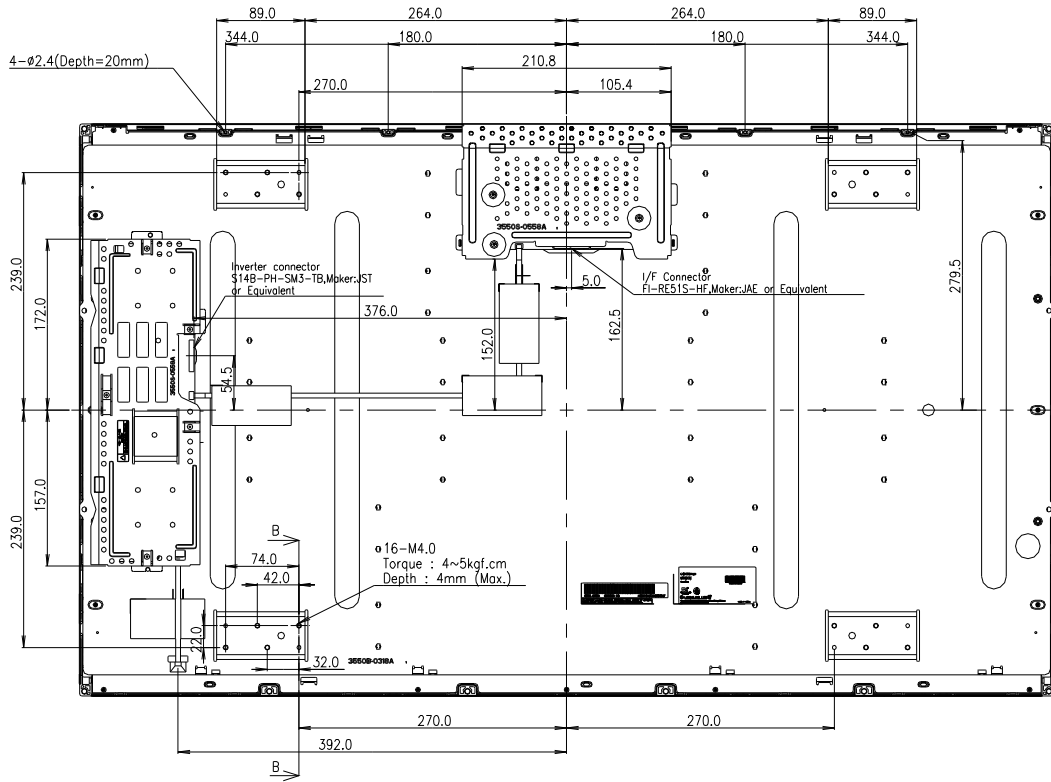

SECTION B-B

Product Specification

6. Reliability**Table 14. ENVIRONMENT TEST CONDITION**

No.	Test Item	Condition
1	High temperature storage test	Ta= 60°C 240h
2	Low temperature storage test	Ta= -20°C 240h
3	High temperature operation test	Ta= 50°C 50%RH 240h
4	Low temperature operation test	Ta= 0°C 240h
5	Vibration test (non-operating)	Wave form : random Vibration level : 1.0Grms Bandwidth : 10-300Hz Duration : X,Y,Z, 30 min One time each direction
6	Shock test (non-operating)	Shock level : 50Grms Waveform : half sine wave, 11ms Direction : ± X, ± Y, ± Z One time each direction
7	Humidity condition Operation	Ta= 40 °C ,90%RH
8	Altitude operating storage / shipment	0 - 15,000 ft 0 - 40,000 ft

Note : Before and after Reliability test, LCM should be operated with normal function.

7. International Standards

7-1. Safety

- a) UL 60065, 7th Edition, dated June 30, 2003, Underwriters Laboratories, Inc., Standard for Audio, Video and Similar Electronic Apparatus.
- b) CAN/CSA C22.2, No. 60065:03, Canadian Standards Association, Standard for Audio, Video and Similar Electronic Apparatus.
- c) IEC60065:2001, 7th Edition CB-scheme and EN 60065:2002, Safety requirements for Audio, Video and Similar Electronic Apparatus..

7-2. EMC

- a) ANSI C63.4 "Methods of Measurement of Radio-Noise Emissions from Low-Voltage Electrical and Electrical Equipment in the Range of 9kHz to 40GHz. "American National Standards Institute(ANSI), 1992
- b) CISPR13 "Limits and Methods of Measurement of Radio interference characteristics of Sound and Television broadcast receivers and associated equipment"
CISPR22 "Limits and Methods of Measurement of Radio interference characteristics of Information Technology Equipment" International Special Committee on Radio Interference.
- c) EN55013 "Limits and Methods of Measurement of Radio interference characteristics of Sound and Television broadcast receivers and associated equipment"
EN55022 "Limits and Methods of Measurement of Radio interference characteristics of Information Technology Equipment" European Committee for Electro Technical Standardization.(CENELEC), 1988(Including A1:2000)

Product Specification

8. Packing**8-1. Designation of Lot Mark**

a) Lot Mark

A	B	C	D	E	F	G	H	I	J	K	L	M
---	---	---	---	---	---	---	---	---	---	---	---	---

A,B,C : SIZE(INCH)

D : YEAR

F : PANEL CODE

H : ASSEMBLY CODE

E : MONTH

G : FACTORY CODE

I,J,K,L,M : SERIAL NO.

Note

1. YEAR

Year	2001	2002	2003	2004	2005	2006	2007	2008	2009	2010
Mark	1	2	3	4	5	6	7	8	9	0

2. MONTH

Month	Jan	Feb	Mar	Apr	May	Jun	Jul	Aug	Sep	Oct	Nov	Dec
Mark	1	2	3	4	5	6	7	8	9	A	B	C

b) Location of Lot Mark

Serial NO. is printed on the label. The label is attached to the backside of the LCD module.
This is subject to change without prior notice.

8-2. Packing Form

a) Package quantity in one Pallet : 12 pcs

b) Pallet Size : 1140 mm X 990 mm X 810 mm.

Product Specification

9. Precautions

Please pay attention to the followings when you use this TFT LCD module.

9-1. Mounting Precautions

- (1) You must mount a module using specified mounting holes (Details refer to the drawings).
- (2) You should consider the mounting structure so that uneven force (ex. Twisted stress) is not applied to the module. And the case on which a module is mounted should have sufficient strength so that external force is not transmitted directly to the module.
- (3) Please attach the surface transparent protective plate to the surface in order to protect the polarizer. Transparent protective plate should have sufficient strength in order to resist external force.
- (4) You should adopt radiation structure to satisfy the temperature specification.
- (5) Acetic acid type and chlorine type materials for the cover case are not desirable because the former generates corrosive gas of attacking the polarizer at high temperature and the latter causes circuit break by electro-chemical reaction.
- (6) Do not touch, push or rub the exposed polarizers with glass, tweezers or anything harder than HB pencil lead. And please do not rub with dust clothes with chemical treatment. Do not touch the surface of polarizer for bare hand or greasy cloth. (Some cosmetics are detrimental to the polarizer.)
- (7) When the surface becomes dusty, please wipe gently with absorbent cotton or other soft materials like chamois soaks with petroleum benzene. Normal-hexane is recommended for cleaning the adhesives used to attach front / rear polarizers. Do not use acetone, toluene and alcohol because they cause chemical damage to the polarizer.
- (8) Wipe off saliva or water drops as soon as possible. Their long time contact with polarizer causes deformations and color fading.
- (9) Do not open the case because inside circuits do not have sufficient strength.

9-2. Operating Precautions

- (1) The spike noise causes the mis-operation of circuits. It should be lower than following voltage :
 $V = \pm 200\text{mV}$ (Over and under shoot voltage)
- (2) Response time depends on the temperature. (In lower temperature, it becomes longer.)
- (3) Brightness depends on the temperature. (In lower temperature, it becomes lower.)
 And in lower temperature, response time (required time that brightness is stable after turned on) becomes longer.
- (4) Be careful for condensation at sudden temperature change. Condensation makes damage to polarizer or electrical contacted parts. And after fading condensation, smear or spot will occur.
- (5) When fixed patterns are displayed for a long time, remnant image is likely to occur.
- (6) Module has high frequency circuits. Sufficient suppression to the electromagnetic interference shall be done by system manufacturers. Grounding and shielding methods may be important to minimize the interference.
- (7) Please do not give any mechanical and/or acoustical impact to LCM. Otherwise, LCM can't be operated its full characteristics perfectly.
- (8) A screw which is fastened up the steels should be a machine screw.
 (if not, it causes metallic foreign material and deal LCM a fatal blow)
- (9) Please do not set LCD on its edge.
- (10) It is recommended to avoid the signal cable and conductive material over the inverter transformer for it can cause the abnormal display and temperature rising.
- (11) Partial darkness may happen during 3~5 minutes when LCM is operated initially in condition that luminance is under 40% at low temperature (under 5°C). This phenomenon which disappears naturally after 3~5 minutes is not a problem about reliability but LCD characteristic.

9-3. Electrostatic Discharge Control

Since a module is composed of electronic circuits, it is not strong to electrostatic discharge. Make certain that treatment persons are connected to ground through wrist band etc. And don't touch interface pin directly.

9-4. Precautions for Strong Light Exposure

Strong light exposure causes degradation of polarizer and color filter.

9-5. Storage

When storing modules as spares for a long time, the following precautions are necessary.

- (1) Store them in a dark place. Do not expose the module to sunlight or fluorescent light. Keep the temperature between 5°C and 35°C at normal humidity.
- (2) The polarizer surface should not come in contact with any other object.
It is recommended that they be stored in the container in which they were shipped.

9-6. Handling Precautions for Protection Film

- (1) The protection film is attached to the bezel with a small masking tape.
When the protection film is peeled off, static electricity is generated between the film and polarizer.
This should be peeled off slowly and carefully by people who are electrically grounded and with well ion-blown equipment or in such a condition, etc.
- (2) When the module with protection film attached is stored for a long time, sometimes there remains a very small amount of glue still on the bezel after the protection film is peeled off.
- (3) You can remove the glue easily. When the glue remains on the bezel surface or its vestige is recognized, please wipe them off with absorbent cotton waste or other soft material like chamois soaked with normal-hexane.

APPENDIX-I-1

■ Required signal assignment for Flat Link (Thine : THC63LVD103) Transmitter(Pin7="L")

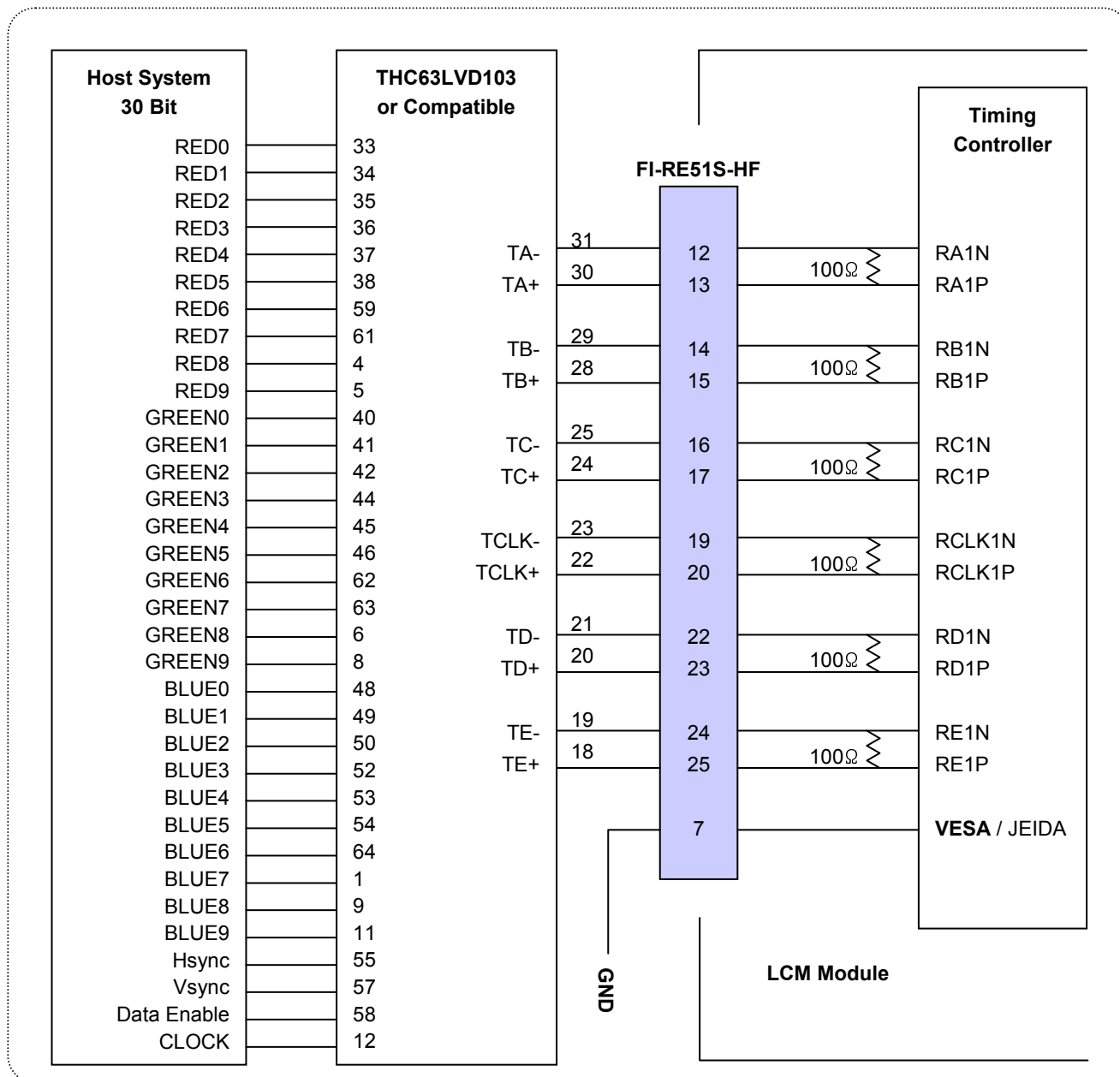

Notes:

1. The LCD module uses a 100 Ohm(Ω) resistor between positive and negative lines of each receiver input.
2. Refer to LVDS transmitter data sheet for detail descriptions. (THC63LVD103 or Compatible)
3. '7' means MSB and '0' means LSB at R,G,B pixel data.

Product Specification

APPENDIX-I-2

Required signal assignment for Flat Link (Thine : THC63LVD103) Transmitter(Pin7="H")

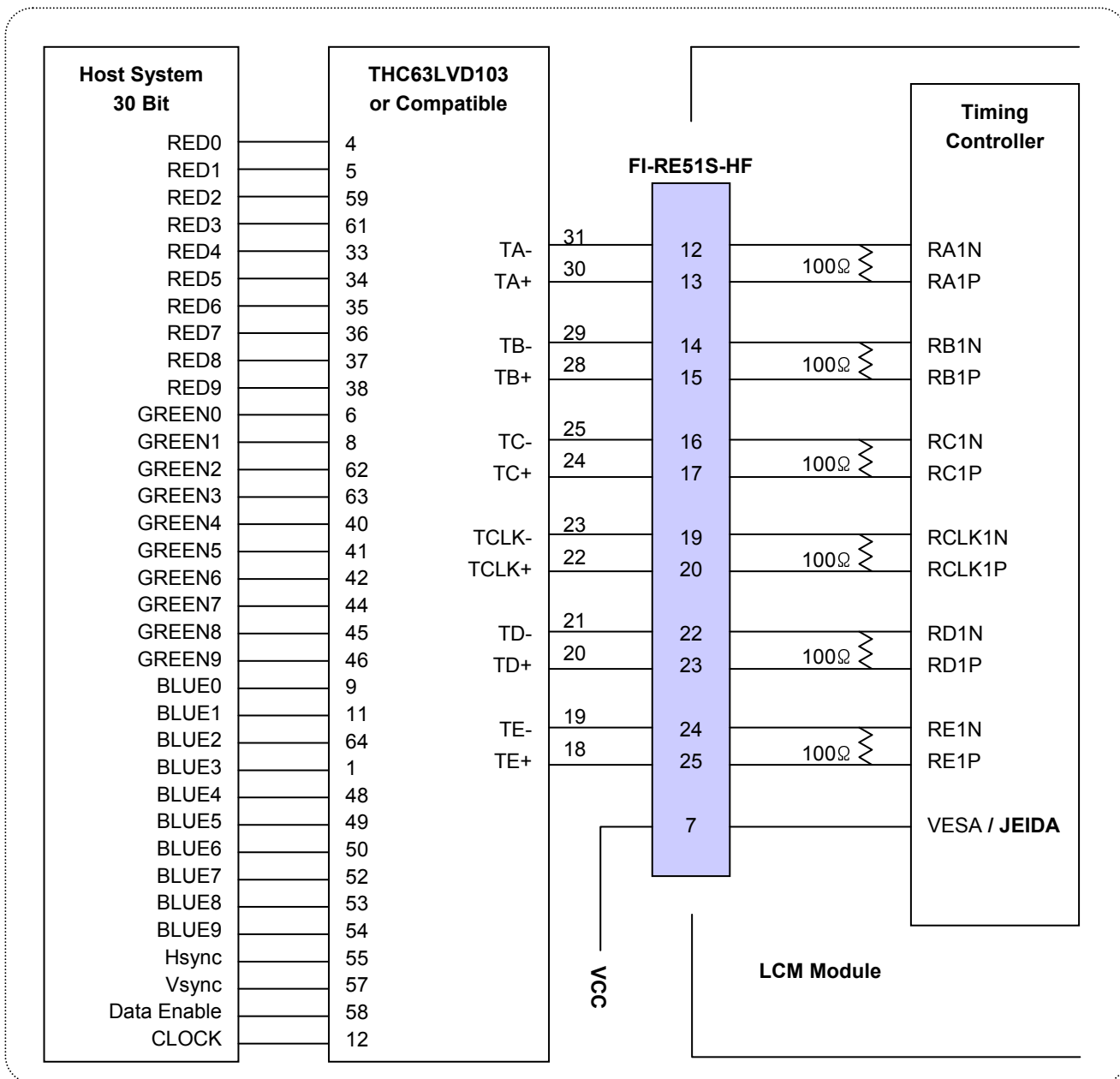

Notes:

1. The LCD module uses a 100 Ohm(Ω) resistor between positive and negative lines of each receiver input.
2. Refer to LVDS transmitter data sheet for detail descriptions. (THC63LVD103 or Compatible)
3. '7' means MSB and '0' means LSB at R,G,B pixel data.

Product Specification

APPENDIX-II

■ Pallet Ass'y

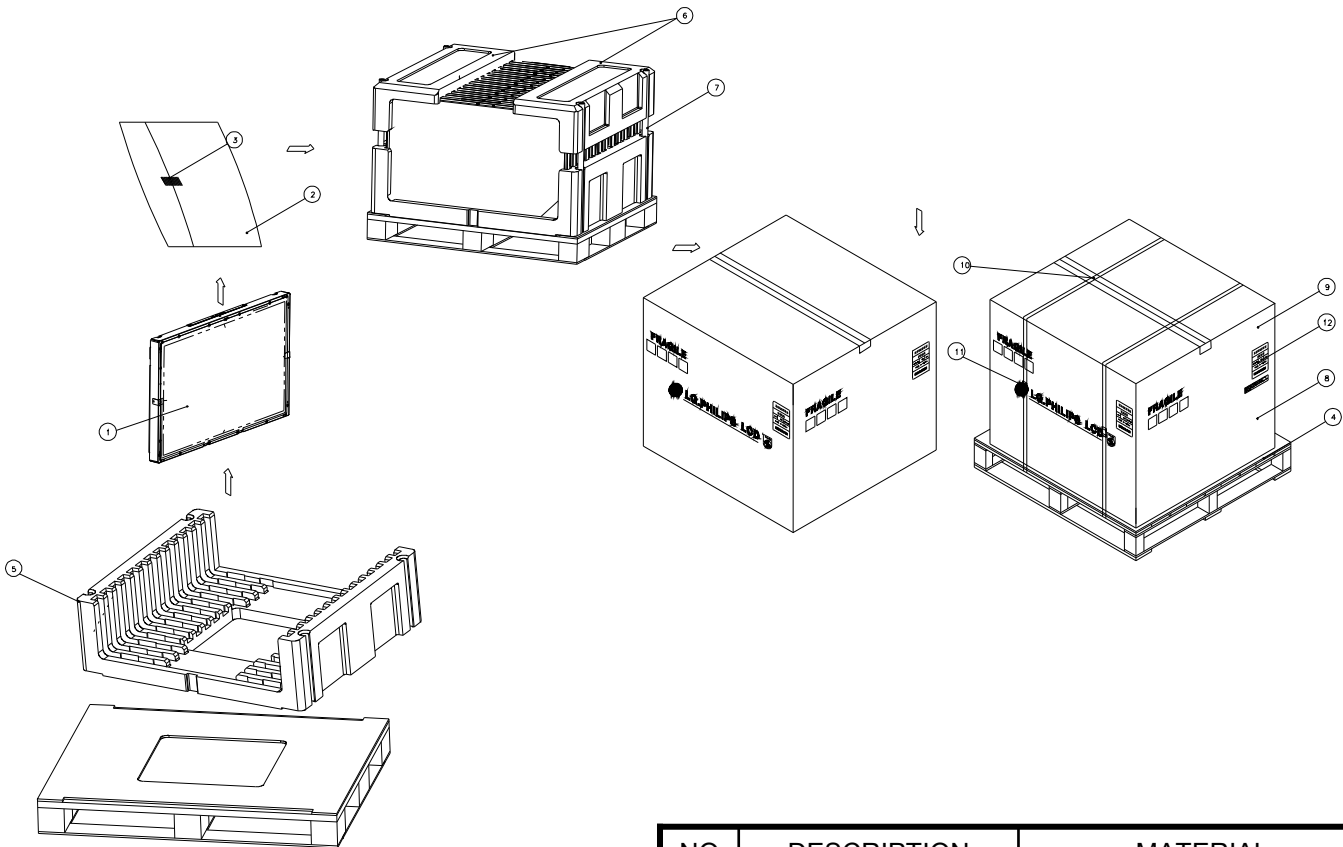

NO.	DESCRIPTION	MATERIAL
1	LCD Module	
2	BAG	42INCH
3	TAPE	MASKING 20MMX50M
4	PALLET	PAPER 1140X990X130MM
5	PACKING,BOTTOM	EPS
6	PACKING, TOP	EPS
7	ANGLE,POST	PAPER
8	ANGLE,PACKING	PAPER
9	BAND,CLIP	STEEL
10	BAND	PP
11	LABEL	YUPO 80G 100X100

APPENDIX- III

■ LCM Label

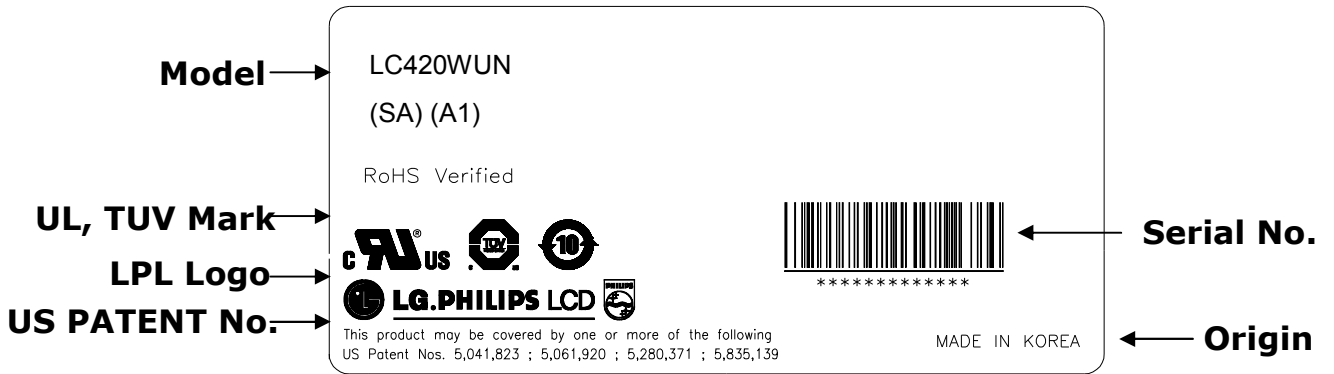

■ Serial No. (See CAS 24page for more information)

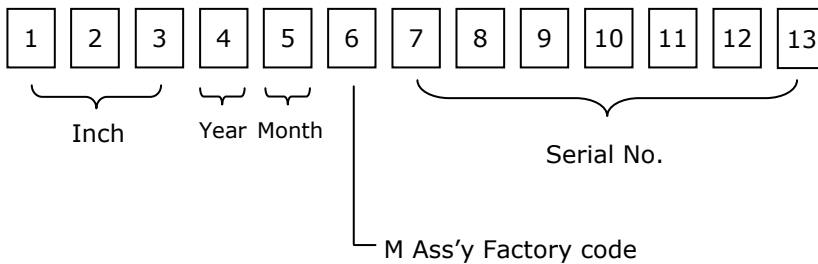

APPENDIX- IV

■ Pallet Label

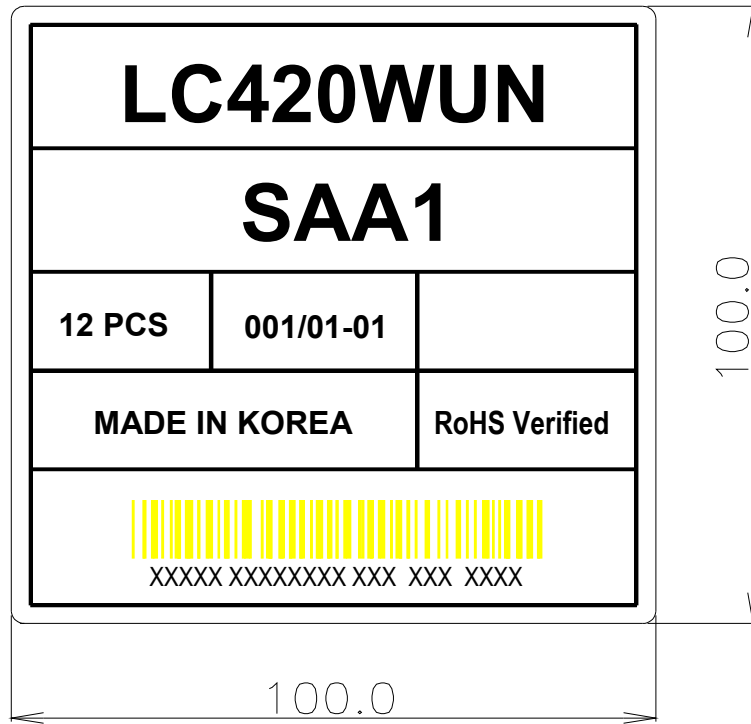

APPENDIX- V-1

■ LCM DCR Only (Reference)

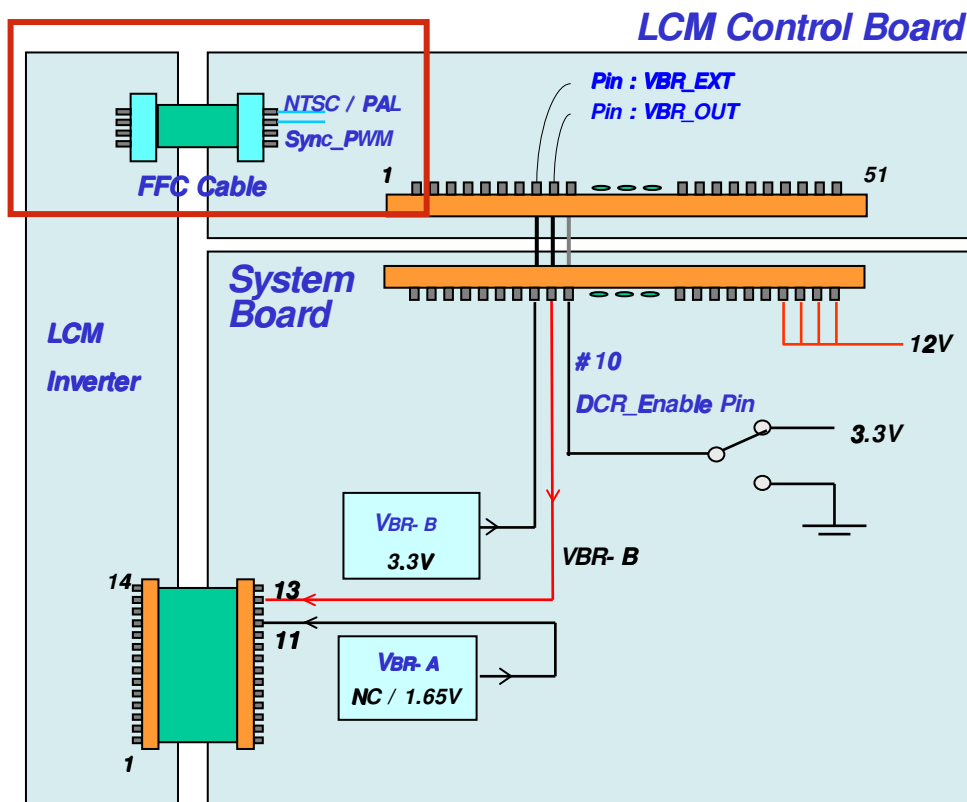

■ DCR_Enable Option Pin Description

DCR_Enable	On(3.3V)	Off (0V)
VBR_OUT (VBR-B) Signal Source	From T-Con (ASIC)	From System (VBR_EXT Pin)
VBR-B	0V ~ 3.3V	3.3V
VBR-A	1.65V or NC	1.65V or NC
DCR Level	5000 : 1	1300 : 1

APPENDIX- V-2

■ System DCR (Dynamic Contrast Ratio)- Max 13000:1 (Reference)

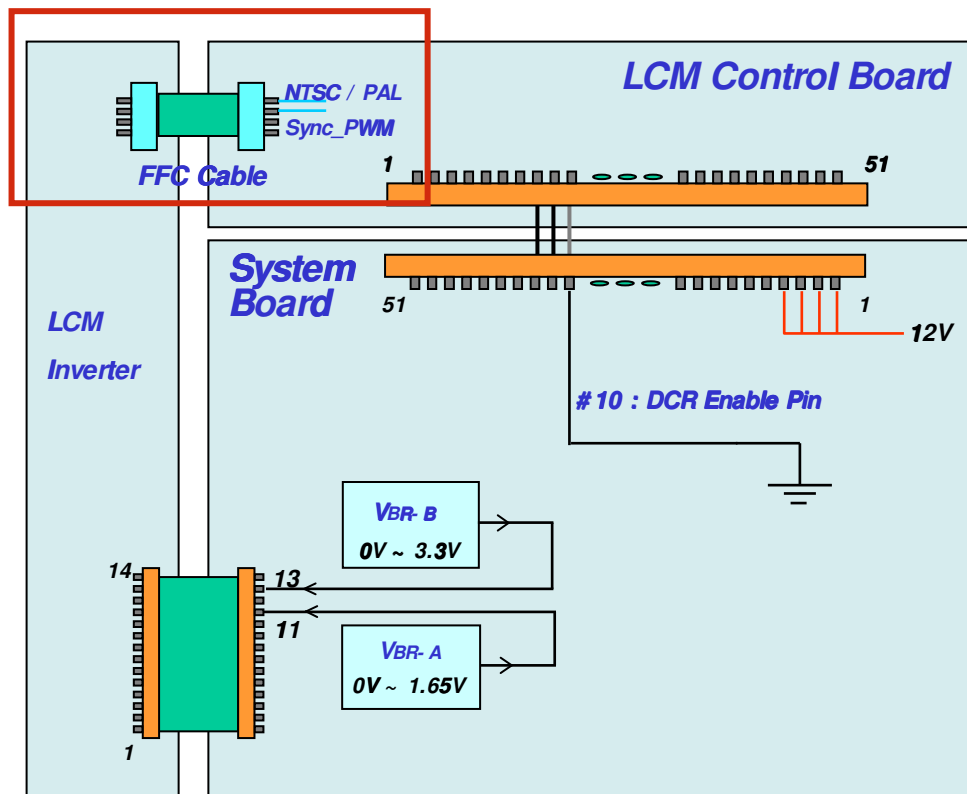

V _{BR-B}	0V ~ 3.3V	3.3V	V _{BR-A,B} Voltage	Function
V _{BR-A}	0V ~ 1.65V	1.65V	V _{BR-B} : 3.3V V _{BR-A} : 1.65V	Maximum Brightness (100%) (DCR Condition)
DCR Level	13000 : 1	1300 : 1	0V	Minimum Brightness (10%)

Note : 1. To make DCR Max 13000:1, V_{BR-A} and V_{BR-B} must be given by system.

2. DCR Max 13000:1 is defined mathematically as :

$$DCR = \text{Maximum DCR}_n \text{ (n=1, 2, 3, 4, 5)}$$

$$DCR_n = \frac{\text{Surface Luminance at position n with all white pixels (V}_{BR-B}=3.3V, V_{BR-A}=1.65V)}{\text{Surface Luminance at position n with all black pixels (V}_{BR-B}=0V, V_{BR-A}=0V)}$$

n = the Position number(1, 2, 3, 4, 5). For more information, see FIG 2.

3. Measurement Sequence (aging time 10 min each pattern) :

- ① Turn On LCM
- ② Measure Black Luminance (V_{BR-B}=0V, V_{BR-A}=0V)
- ③ Measure White Luminance (V_{BR-B}=3.3V, V_{BR-A}=1.65V)

4. In case the lowest minimum brightness is continued, it can affect the lamp reliability and appear the partial darkness.