



# SmarterGlass

state-of-the-art display solutions

[www.smarterglass.com](http://www.smarterglass.com)  
978 997 4104  
[sales@smarterglass.com](mailto:sales@smarterglass.com)

**SAMSUNG**

**ELECTRONICS**

Approval



DATE : Jan. 02, 2006

**SAMSUNG TFT-LCD**

**MODEL NO. : LTN150XG-L02**

NOTE : Extension code [ -P ]  
→ LTN150XG-L02-P  
Surface type [ Glare ]

Any Modification of Spec is not allowed without SEC' permission

APPROVED BY :

*K. H. Shin*

PREPARED BY : LCD Application Engineering Group 1, TCS Team

**SAMSUNG ELECTRONICS CO., LTD.**



**Samsung Secret**

## CONTENTS

Revision History	----- ( 3 )
General Description	----- ( 4 )
1. Absolute Maximum Ratings	----- ( 5 )
1.1 Absolute Ratings of environment	
1.2 Electrical Absolute Ratings	
2. Optical Characteristics	----- ( 7 )
3. Electrical Characteristics	----- ( 10 )
3.1 TFT LCD Module	
3.2 Backlight Unit	
4. Block Diagram	----- ( 13 )
4.1 TFT LCD Module	
4.2 Backlight Unit	
5. Input Terminal Pin Assignment	----- ( 14 )
5.1 Input Signal & Power	
5.2 LVDS Interface	
5.3 Backlight Unit	
5.4 Timing Diagrams of LVDS For Transmitting	
5.5 Input Signals, Basic Display Colors and Gray Scale of Each Color.	
5.6 Pixel format	
6. Interface Timing	----- ( 19 )
6.1 Timing Parameters(DE Mode)	
6.2 Timing Diagrams of interface Signal (DE Mode)	
6.3 Power ON/OFF Sequence	
7. Outline Dimension	----- ( 21 )
8. Packing	----- ( 23 )
9. Markings & Others	----- ( 24 )
10. General Precautions	----- ( 25 )
11. EDID	----- ( 27 )

**Samsung Secret**

# REVISION HISTORY

Approval

Date	Revision No.	Page	Summary
Jan. 2, 2006	A00	All	LTN150XG-L02-P model specification was issued first.

Samsung Secret

## GENERAL DESCRIPTION

### DESCRIPTION

LTN150XG-L02 is a color active matrix TFT (Thin Film Transistor) liquid crystal display (LCD) that uses amorphous silicon TFT as a switching devices. This model is composed of a TFT LCD panel, a driver circuit and a backlight system. The resolution of a 15.0" contains 1,024 x 768 pixels and can display up to 262,144 colors. 6 O'clock direction is the Optimum viewing angle.

### FEATURES

- Ultra High Luminance
- Thin and light weight
- High contrast ratio
- XGA ((1024x768) pixels) resolution
- Low power consumption
- DE (Data enable) only mode.
- 3.3V LVDS Interface
- Pb-free product

### APPLICATIONS

- Notebook PC and desktop monitors
- If the usage of this product is not for PC application, but for others, please contact SEC

## GENERAL INFORMATION

ITEM	SPECIFICATION	UNIT	NOTE
Display area	304.128(H)X228.096(V) (15.0"diagonal)	mm	
Driver element	a-si TFT active matrix		
Display colors	262,144		
Number of pixel	1024 X 768 (XGA)	pixel	
Pixel arrangement	RGB vertical stripe		
Pixel pitch	0.297(H) x 0.297(V)	mm	
Display Mode	Normally white		
Surface treatment	Haze 0, Hard-Coating 2H		

**Samsung Secret**

## Mechanical Information

Item		Min.	Typ.	Max.	Unit	Note
Module size	Horizontal (H)	316.8	317.3	317.8	mm	
	Vertical (V)	241.5	242.0	242.5	mm	
	Depth (D)	-	6.2	6.5	mm	
Weight		-	530	545	g	

Note (1) Measurement condition of outline dimension  
 . Equipment : Vernier Calipers  
 . Push Force : 500g · f (minimum)

## 1. ABSOLUTE MAXIMUM RATINGS

### 1.1 ENVIRONMENTAL ABSOLUTE RATINGS

Item	Symbol	Min.	Max.	Unit	Note
Storage temperate	$T_{STG}$	-20	60	°C	(1)
Operating temperate (Temperature of glass surface)	$T_{OPR}$	0	50	°C	(1)
Shock ( non-operating )	Snop	-	240	G	(2),(4)
Vibration (non-operating)	Vnop	-	2.41	G	(3),(4)

Note (1) Temperature and relative humidity range are shown in the figure below.  
 95 % RH Max. ( $40\text{ °C} \geq T_a$ )  
 Maximum wet - bulb temperature at  $39\text{ °C}$  or less. ( $T_a > 40\text{ °C}$ ) No condensation

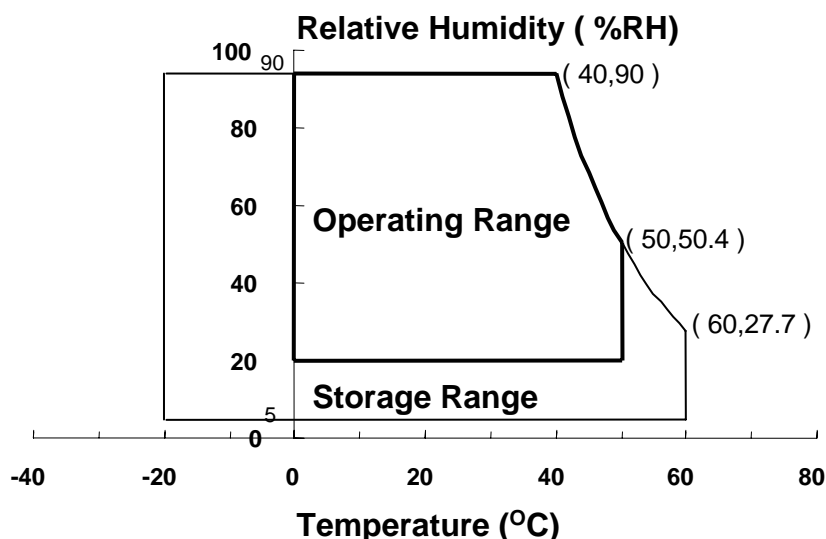

- (2) 2ms, half sine wave, one time for  $\pm X$ ,  $\pm Y$ ,  $\pm Z$ .  
 (3) 5 - 500 Hz, random vibration, 30min for X, Y, Z.  
 (4) At testing Vibration and Shock, the fixture in holding the Module to be tested have to be hard and rigid enough so that the Module would not be twisted or bent by the fixture.

**Samsung Secret**

## 1.2 ELECTRICAL ABSOLUTE RATINGS

## (1) TFT LCD MODULE

 $V_{DD} = 3.3V, V_{SS} = GND = 0V$ 

Item	Symbol	Min.	Max.	Unit	Note
Power Supply Voltage	$V_{DD}$	$V_{DD} - 0.3$	$V_{DD} + 0.3$	V	(1)
Logic Input Voltage	$V_N$	$V_{DD} - 0.3$	$V_{DD} + 0.3$	V	(1)

Note (1) Within  $T_a$  ( $25 \pm 2 \text{ }^\circ\text{C}$ )

## (2) BACK-LIGHT UNIT

 $T_a = 25 \pm 2 \text{ }^\circ\text{C}$ 

Item	Symbol	Min.	Max.	Unit	Note
Lamp Current	$I_L$	2.0	7.0	mArms	(1)
Lamp frequency	$F_L$	50	80	kHz	(1)

Note 1) Permanent damage to the device may occur if maximum values are exceeded  
 Functional operation should be restricted to the conditions described under normal operating conditions.

Samsung Secret

## 2. OPTICAL CHARACTERISTICS

The following items are measured under stable conditions. The optical characteristics should be measured in a dark room or equivalent state with the methods shown in Note (5).  
Measuring equipment : TOPCON BM-5A and PR-650

\* Ta = 25 ± 2 °C, VDD=3.3V, fv= 60Hz, fDCLK = 65MHz, IL = 6.0 mA

Item		Symbol	Condition	Min.	Typ.	Max	Unit	Note	
Contrast Ratio (5 Points)		CR		300	-	-	-	(1), (2), (5)	
Response Time at Ta	Rising	TR	Normal Viewing Angle $\phi = 0$ $\theta = 0$	-	10	15	msec	(1), (3)	
	Falling	TT		-	30	35			
Average Luminance of White (Center)		YL,AVE			250	280	-	cd/m <sup>2</sup>	IL=6.0mA (1), (4)
Color Chromaticity ( CIE )	Red	Rx			0.534	0.564	0.594	-	(1), (5) PR-650
		Ry			0.304	0.334	0.364		
	Green	Gx			0.293	0.323	0.353		
		Gy			0.500	0.530	0.560		
	Blue	Bx			0.120	0.150	0.180		
		By			0.102	0.132	0.162		
	White	Wx			0.283	0.313	0.343		
		Wy		0.299	0.329	0.359			
Viewing Angle	Hor.	$\theta_L$	CR ≥ 10	40	45		Degrees	(1), (5) BM-5A	
		$\theta_H$		40	45				
	Ver.	$\phi_H$		10	15				
		$\phi_L$		30	35				
13 Points White Variation		$\delta_L$		-	-	2.2	-	(6)	

Samsung Secret



Note 1) Definition of Viewing Angle : Viewing angle range( $10 \leq C/R$ )

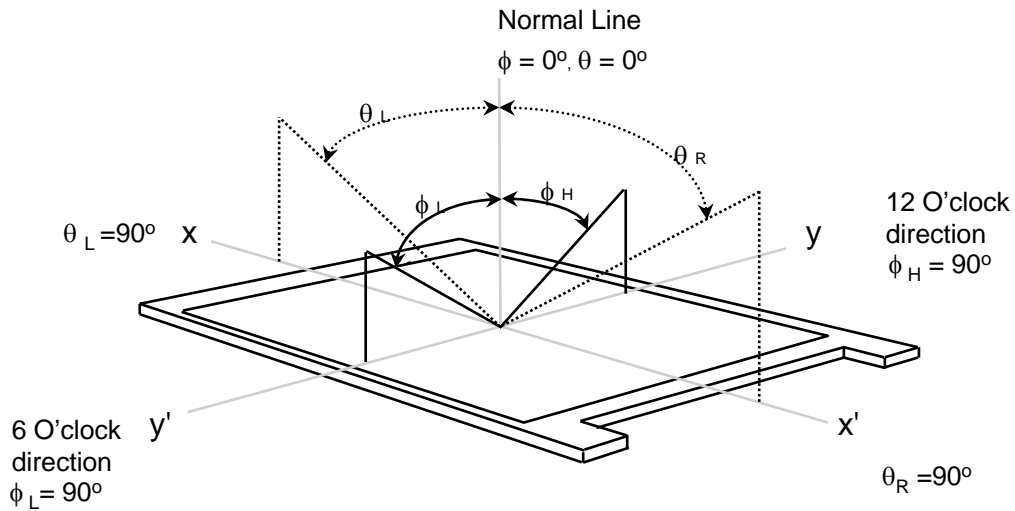

Note 2) Definition of Contrast Ratio (CR) : Ratio of gray max (Gmax) ,gray min (Gmin) at 5 points(4, 5, 7, 9, 10)

$$CR = \frac{CR(4) + CR(5) + CR(7) + CR(9) + CR(10)}{5}$$

Points : (4) , (5) , (7) , (9) , (10) at the figure of Note (6).

Note 3) Definition of Response time :

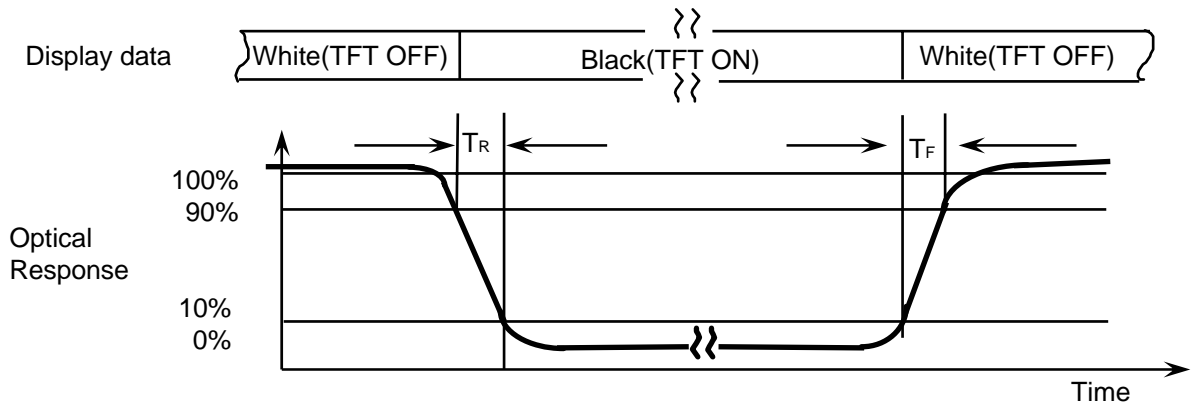

Note 4) Definition of Average Luminance of White : measure the luminance of white at center point.

Average Luminance of White ( $Y_{L,AVE}$ )

$Y_{L,} = Y_{L7}$  POINTS :, (7) at FIGURE OF NOTE 6)

Note 5) After stabilizing and leaving the panel alone at a given temperature for 30 min , the measurement should be executed. Measurement should be executed in a stable, windless, and dark room. 30 min after lighting the backlight. This should be measured in the center of screen.  
 Lamp current : 6.0mA ( Inverter : SIC-130T )  
 Environment condition : Ta = 25 ± 2 °C

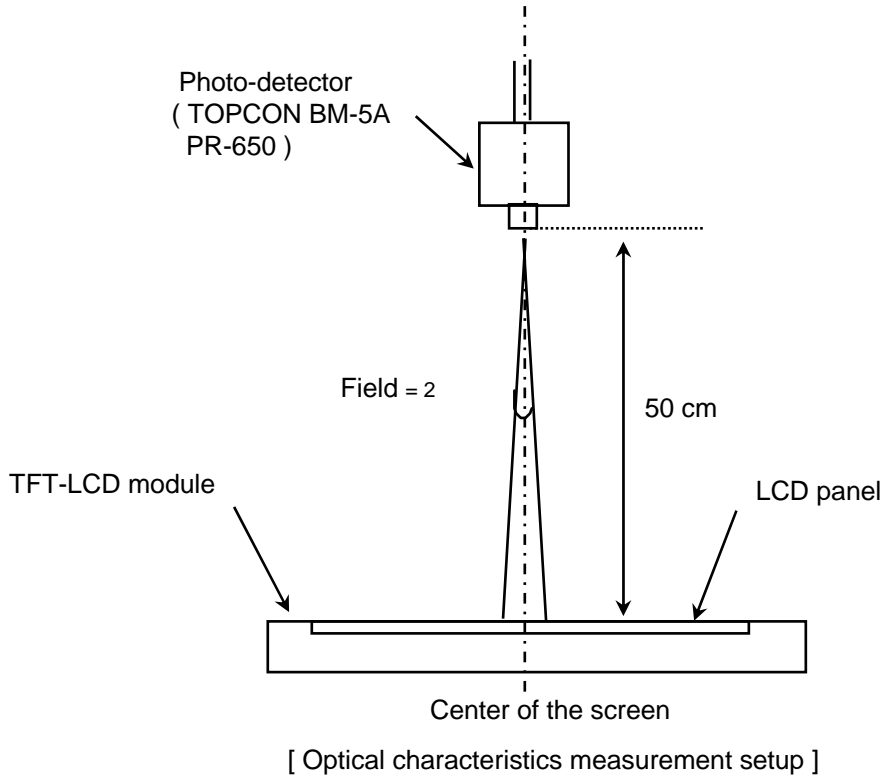

Note 6) Definition of 13 points white variation ( $\delta L$ ), [ ① ~ ⑬ ]

$$\delta L = \frac{\text{Maximum luminance of 13 points}}{\text{Minimum luminance of 13 points}}$$

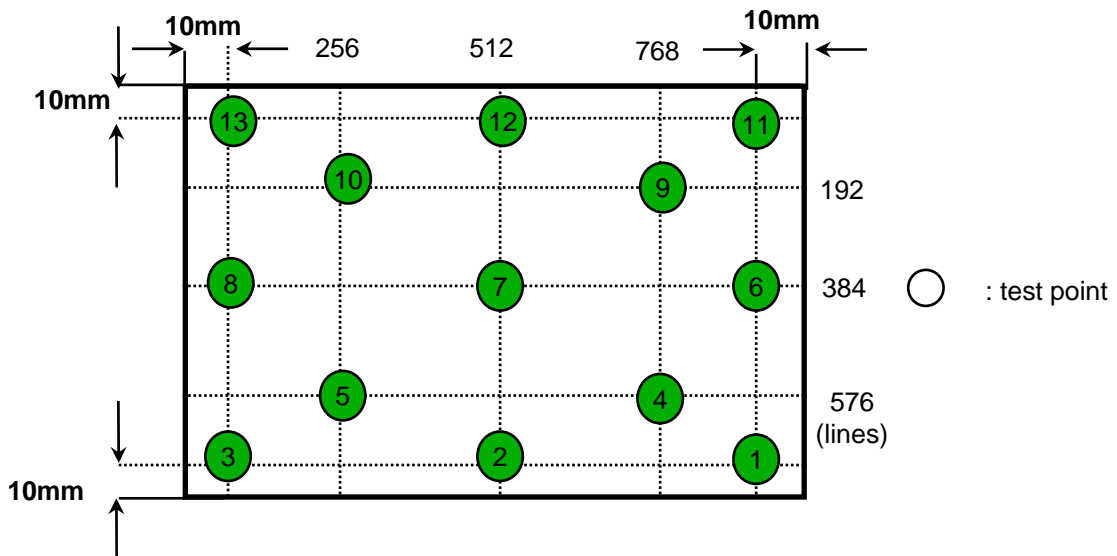

Samsung Secret

### 3. ELECTRICAL CHARACTERISTICS

Approval

#### 3.1 TFT LCD MODULE

Ta= 25 ± 2°C

Item	Symbol	Min.	Typ.	Max.	Unit	Note	
Voltage of Power Supply	V <sub>DD</sub>	3.0	3.3	3.6	V		
Differential Input Voltage for LVDS Receiver Threshold	High	V <sub>IH</sub>	-	-	+100	mV	V <sub>CM</sub> = +1.2V
	Low	V <sub>L</sub>	-100	-	-	mV	
Vsync Frequency	f <sub>v</sub>	-	60	-	Hz		
Hsync Frequency	f <sub>H</sub>	-	48.2	-	KHz		
Main Frequency	f <sub>DCLK</sub>	-	65	-	MHz		
Rush Current	I <sub>RUSH</sub>	-	-	1.5	A	(4)	
Current of Power Supply	White	I <sub>DD</sub>	-	310	-	mA	(2),(3)*a
	Mosaic		-	360	-	mA	(2),(3)*b
	V. Stripe		-	440	500	mA	(2),(3)*c

Note (1) Display data pins and timing signal pins should be connected.( GND = 0V )

(2) f<sub>v</sub> = 60Hz, f<sub>DCLK</sub> = 65MHZ, V<sub>DD</sub> = 3.3V , DC Current.

(3) Power dissipation pattern

\*a) White Pattern

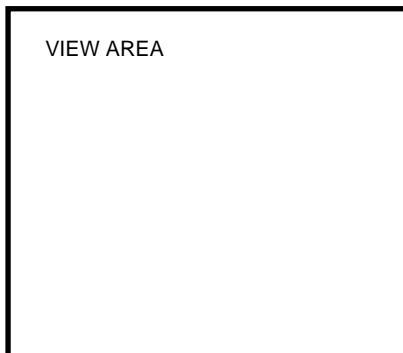

\*b) Mosaic Pattern

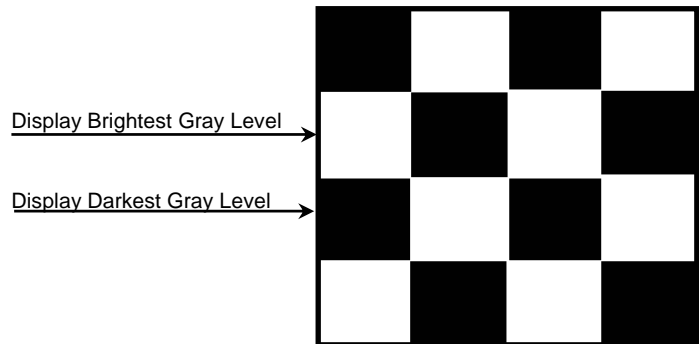

Samsung Secret

\*c) 1dot Vertical stripe pattern

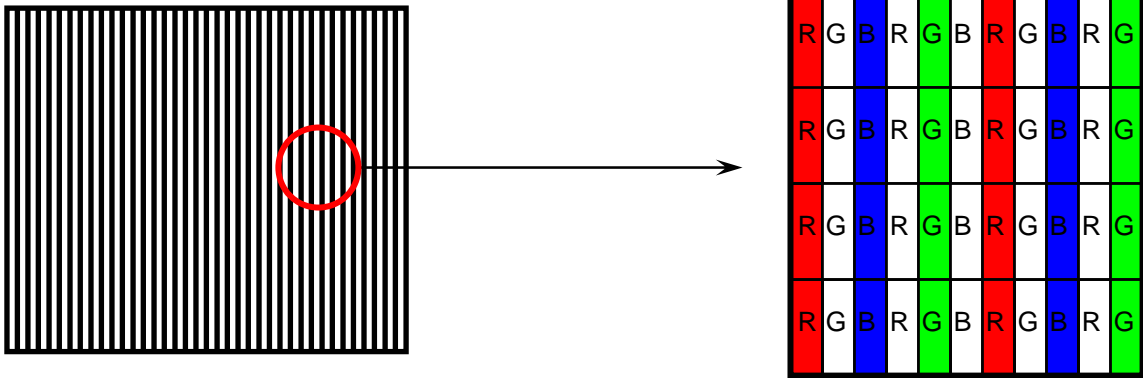

4) Rush current measurement condition

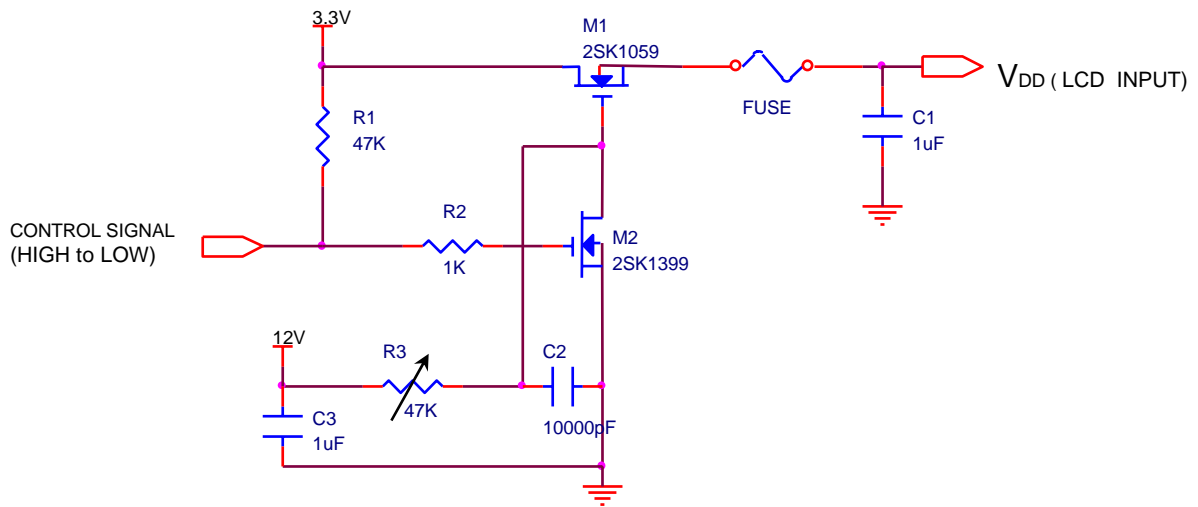

V<sub>DD</sub> rising time is 470us

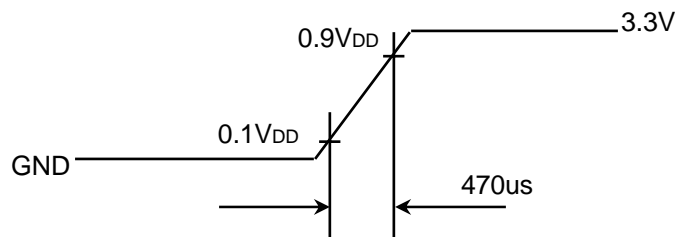

**Samsung Secret**

### 3.2 BACK-LIGHT UNIT

The backlight system is an edge-lighting type with a single CCFT ( Cold Cathode Fluorescent Tube ).  
The characteristics of a single lamp are shown in the following table.

- INVERTER : SEM SIC 130T

Ta= 25 ± 2 °C

Item	Symbol	Min.	Typ.	Max.	Unit	Note
Lamp Current	I <sub>L</sub>	3.0	6.0	6.5	mArms	(1)
Lamp Voltage	V <sub>L</sub>	-	710	-	Vrms	I <sub>L</sub> =6.0mA
Frequency	f <sub>L</sub>	50	60	65	KHz	(2)
Power Consumption	P <sub>L</sub>		4.26		W	(3) I <sub>L</sub> =6.0mA
Operating Life Time	Hr	10,000			Hour	(4)
Startup Voltage	V <sub>s</sub>	-	-	1200	Vrms	25°C, (5)
				1500	Vrms	0°C, (5)
Lamp startup time		-	-	1.0	sec	(5)

**Note) The waveform of the inverter output voltage must be area symmetric and the design of the inverter must have specifications for the modularized lamp.**

The performance of the backlight, for example life time or brightness, is much influenced by the characteristics of the DC-AC inverter for the lamp. So all the parameters of an inverter should be carefully designed so as not to produce too much leakage current from high-voltage output of the inverter. When you design or order the inverter, please make sure that a poor lighting caused by the mismatch of the backlight and the inverter(miss lighting, flicker, etc.) never occur. When you confirm it, the module should be operated in the same condition as it is installed in your instrument.

Note (1) Lamp current is measured with a high frequency current meter as shown below.

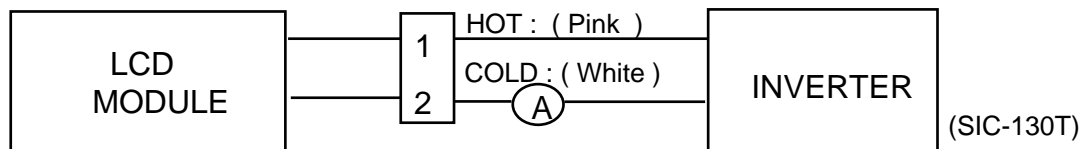

(2) Lamp frequency may produce interference with horizontal synchronous frequency and this may cause line flow on the display. Therefore lamp frequency should be detached from the horizontal synchronous frequency and its harmonics as far as possible in order to avoid interference.

(3) Refer to I<sub>L</sub> × V<sub>L</sub> to calculate.

(4) Life time (Hr) of a lamp can be defined as the time in which it continues to operate under the condition Ta= 25 ± 2 °C and I<sub>L</sub> = 6.0 mArms until one of the following event occurs.

1. When the brightness becomes 50% or lower than the original.
2. When the Effective ignition length becomes 80% or lower than the original value.  
(Effective ignition length is defined as an area that has less than 70% brightness compared to the brightness in the center point.)

(5) The inverter open voltage - this voltage should be measured after ballast capacitor- have to be larger than the lamp startup voltage, otherwise backlight may has blinking for a moment after turns on or not be turned on.

If an inverter has shutdown function it should keep its open voltage for longer than 1 second even if lamp connector open.

**Samsung Secret**

## 4. BLOCK DIAGRAM

### 4.1 TFT LCD Module

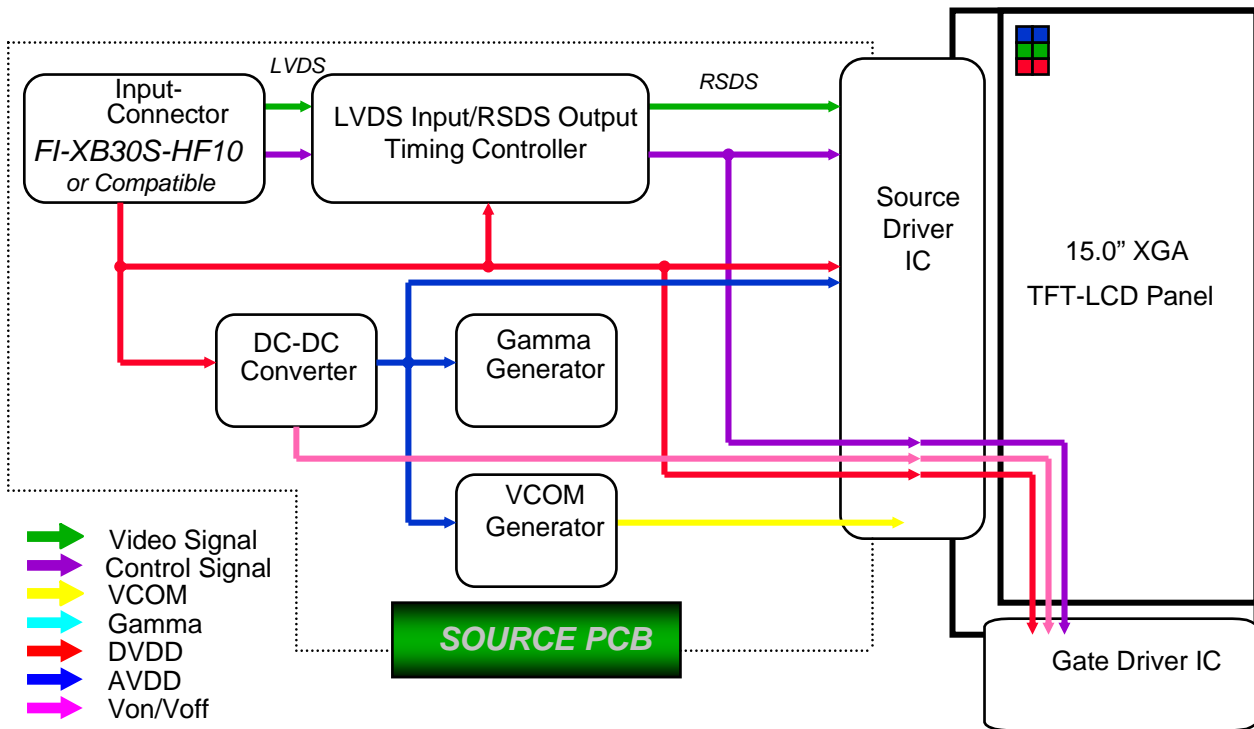

### 4.2 BACK-LIGHT UNIT

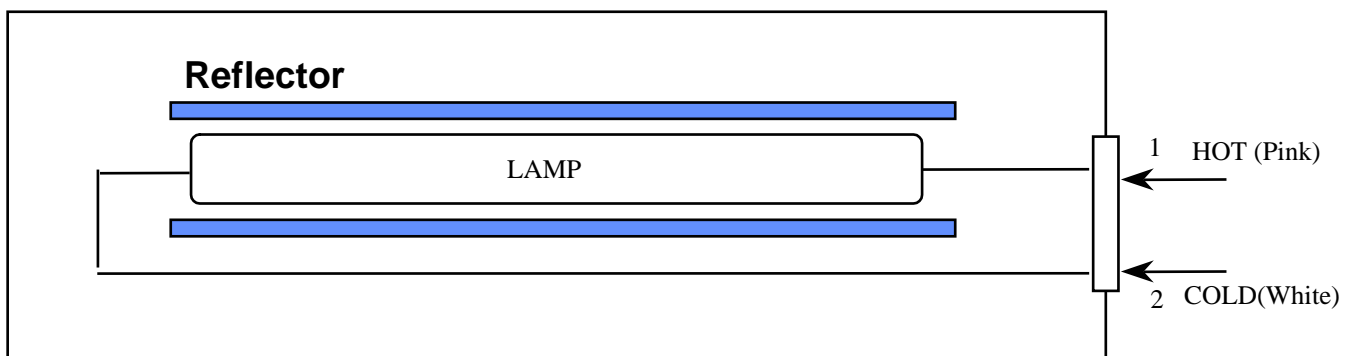

Note) The output of the inverter may change according to the material of the reflector.

**Samsung Secret**

## 5. INPUT TERMINAL PIN ASSIGNMENT

5.1. Input Signal & Power LVDS, Connector : (JAE, FI-XB30S-HF10 or Compatible)  
Mating Connector :(JAE FI-X30M or Compatible)

PIN NO	SYMBOL	FUNCTION	POLARITY	REMARK
1	VSS	Ground		
2	VDD	POWER SUPPLY +3.3V		
3	VDD	POWER SUPPLY +3.3V		
4	VEEDID	DDC 3.3V Power		
5	NC	No Connection		
6	CLKEDID	DDC Clock		
7	DATAEDID	DDC data		
8	RxIN0-	LVDS Differential Data INPUT (R0-R5,G0)	Negative	
9	RxIN0+	LVDS Differential Data INPUT (R0-R5,G0)	Positive	
10	VSS	Ground		
11	RxIN1-	LVDS Differential Data INPUT (G1-G5,B0-B1)	Negative	
12	RxIN1+	LVDS Differential Data INPUT (G1-G5,B0-B1)	Positive	
13	VSS	Ground		
14	RxIN2-	LVDS Differential Data INPUT (B2-B5,Sync,DE)	Negative	
15	RxIN2+	LVDS Differential Data INPUT (B2-B5,Sync,DE)	Positive	
16	VSS	Ground		
17	RxCLK-	LVDS Differential Data INPUT (Clock)	Negative	
18	RxCLK+	LVDS Differential Data INPUT (Clock)	Positive	
19	VSS	Ground		
20	NC	No Connection		
21	NC	No Connection		
22	NC	No Connection		
23	NC	No Connection		
24	NC	No Connection		
25	NC	No Connection		
26	NC	No Connection		
27	NC	No Connection		
28	NC	No Connection		
29	NC	No Connection		
30	NC	No Connection		

**Samsung Secret**

## 5.2 LVDS Interface : Transmitter DS90CF383 or Compatible

Pin No.	Name	RGB Signal	Pin No.	Name	RGB Signal
51	TxIN0	R0	14	TxIN14	G5
52	TxIN1	R1	15	TxIN15	B0
54	TxIN2	R2	19	TxIN18	B1
55	TxIN3	R3	20	TxIN19	B2
56	TxIN4	R4	22	TxIN20	B3
3	TxIN6	R5	23	TxIN21	B4
4	TxIN7	G0	24	TxIN22	B5
6	TxIN8	G1	27	TxIN24	Hsync
7	TxIN9	G2	28	TxIN25	Vsync
11	TxIN12	G3	30	TxIN26	DE
12	TxIN13	G4	31	TxCLKIN	Clock

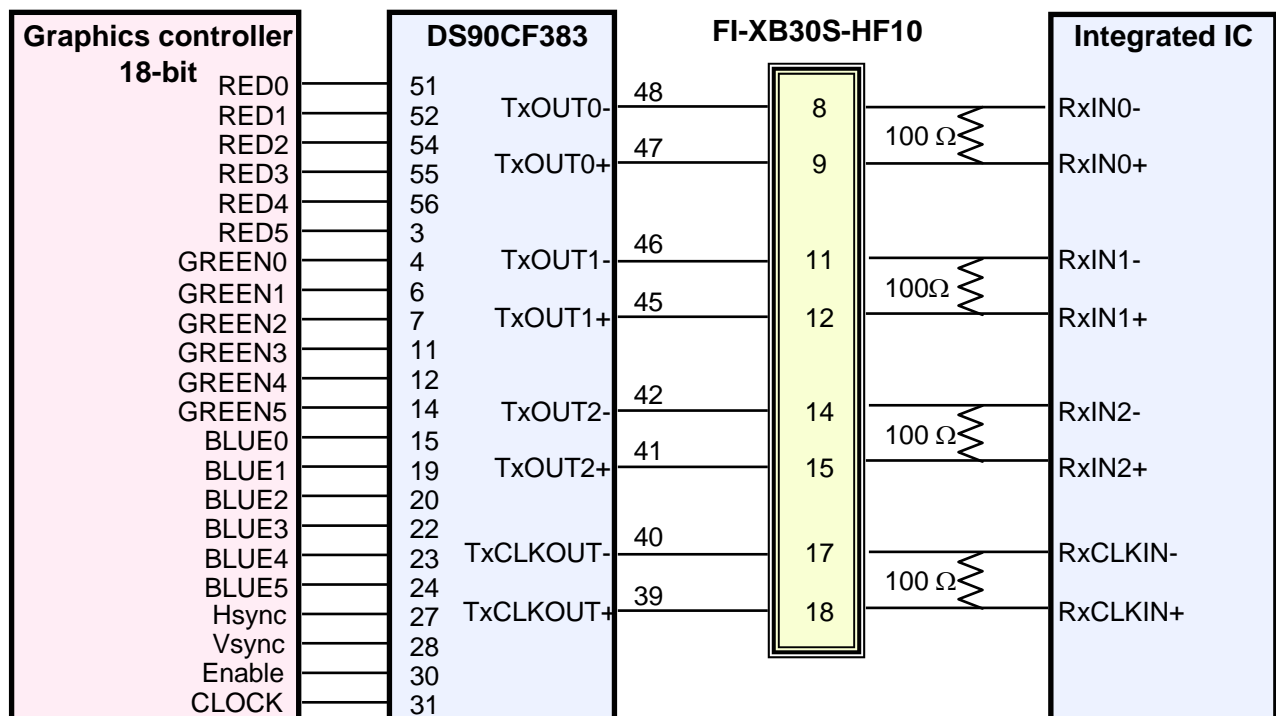
**LVDS INTERFACE**

Note : The LCD Module uses a 100ohm resistor between positive and negative lines of each receiver input.

**Samsung Secret**



### 5.3 BACK LIGHT UNIT

Connector : JST BHSR - 02VS -1  
 Mating Connector : SM02B-BHSS-1(JST)

Pin NO.	Symbol	Color	Function
1	HOT	Pink	High Voltage
2	COLD	White	Low Voltage

### 5.4 Timing Diagrams of LVDS For Transmission

LVDS Receiver : Integrated T-CON

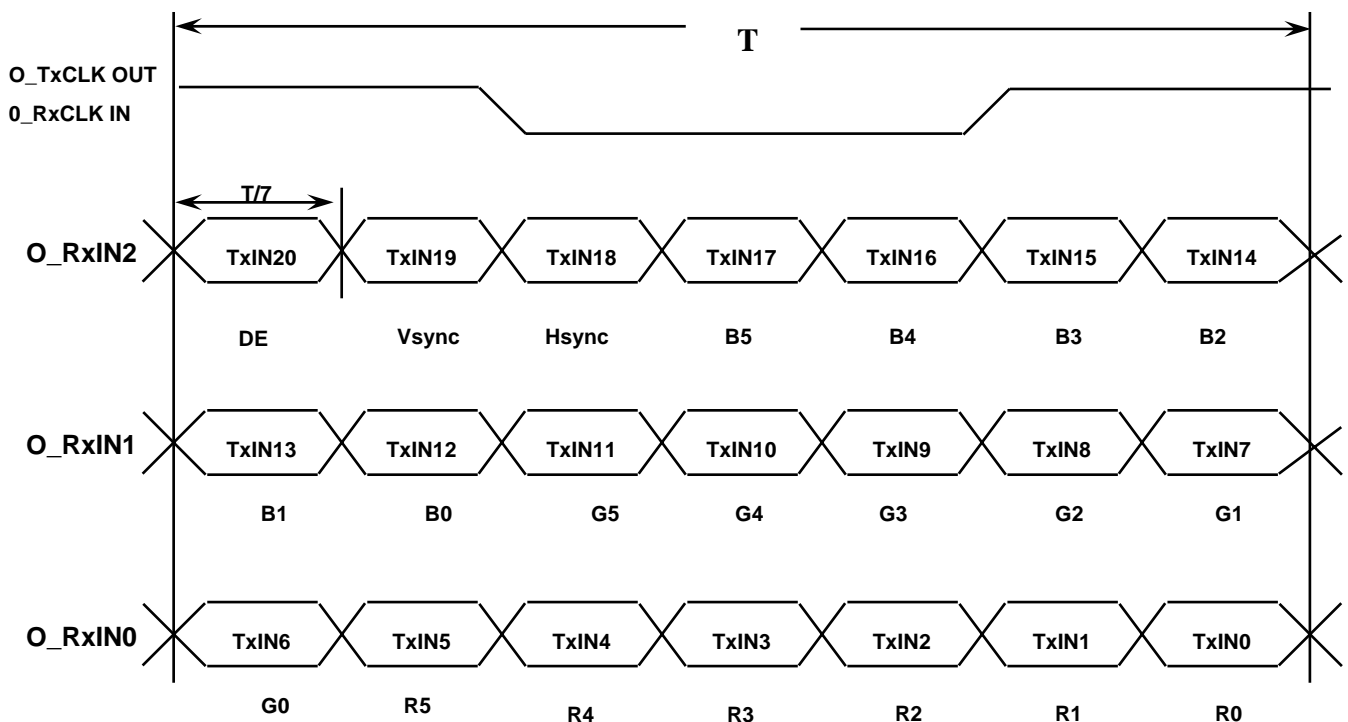

Samsung Secret

## 5.5 Input Signals, Basic Display Colors and Gray Scale of Each Color

Color	Display	Data Signal																Gray Scale Level	
		Red					Green					Blue							
		R0	R1	R2	R3	R4	R5	G0	G1	G2	G3	G4	G5	B0	B1	B2	B3		B4
Basic Colors	Black	0	0	0	0	0	0	0	0	0	0	0	0	0	0	0	0	0	-
	Blue	0	0	0	0	0	0	0	0	0	0	0	0	1	1	1	1	1	-
	Green	0	0	0	0	0	0	1	1	1	1	1	1	0	0	0	0	0	-
	Cyan	0	0	0	0	0	0	1	1	1	1	1	1	1	1	1	1	1	-
	Red	1	1	1	1	1	1	0	0	0	0	0	0	0	0	0	0	0	-
	Magenta	1	1	1	1	1	1	0	0	0	0	0	0	1	1	1	1	1	-
	Yellow	1	1	1	1	1	1	1	1	1	1	1	1	0	0	0	0	0	-
	White	1	1	1	1	1	1	1	1	1	1	1	1	1	1	1	1	1	-
Gray Scale Of Red	Black	0	0	0	0	0	0	0	0	0	0	0	0	0	0	0	0	0	R0
	Dark	1	0	0	0	0	0	0	0	0	0	0	0	0	0	0	0	0	R1
	↑	0	1	0	0	0	0	0	0	0	0	0	0	0	0	0	0	0	R2
	:	:	:	:	:	:	:	:	:	:	:	:	:	:	:	:	:	:	R3~R60
	:	:	:	:	:	:	:	:	:	:	:	:	:	:	:	:	:	:	
	↓	1	0	1	1	1	1	0	0	0	0	0	0	0	0	0	0	0	R61
	Light	0	1	1	1	1	1	0	0	0	0	0	0	0	0	0	0	0	R62
	Red	1	1	1	1	1	1	0	0	0	0	0	0	0	0	0	0	0	R63
Gray Scale Of Green	Black	0	0	0	0	0	0	0	0	0	0	0	0	0	0	0	0	0	G0
	Dark	0	0	0	0	0	0	1	0	0	0	0	0	0	0	0	0	0	G1
	↑	0	0	0	0	0	0	0	1	0	0	0	0	0	0	0	0	0	G2
	:	:	:	:	:	:	:	:	:	:	:	:	:	:	:	:	:	:	G3~G60
	:	:	:	:	:	:	:	:	:	:	:	:	:	:	:	:	:	:	
	↓	0	0	0	0	0	0	1	0	1	1	1	1	0	0	0	0	0	G61
	Light	0	0	0	0	0	0	0	1	1	1	1	1	0	0	0	0	0	G62
	Green	0	0	0	0	0	0	1	1	1	1	1	1	0	0	0	0	0	G63
Gray Scale Of Blue	Black	0	0	0	0	0	0	0	0	0	0	0	0	0	0	0	0	0	B0
	Dark	0	0	0	0	0	0	0	0	0	0	0	0	1	0	0	0	0	B1
	↑	0	0	0	0	0	0	0	0	0	0	0	0	0	1	0	0	0	B2
	:	:	:	:	:	:	:	:	:	:	:	:	:	:	:	:	:	:	B3~B60
	:	:	:	:	:	:	:	:	:	:	:	:	:	:	:	:	:	:	
	↓	0	0	0	0	0	0	0	0	0	0	0	0	1	0	1	1	1	B61
	Light	0	0	0	0	0	0	0	0	0	0	0	0	0	1	1	1	1	B62
	Blue	0	0	0	0	0	0	0	0	0	0	0	0	1	1	1	1	1	B63

Note 1) Definition of gray :

Rn: Red gray, Gn: Green gray, Bn: Blue gray (n=gray level)

Note 2) Input signal: 0 =Low level voltage, 1=High level voltage

Samsung Secret

### 5.6 Pixel Format in the display

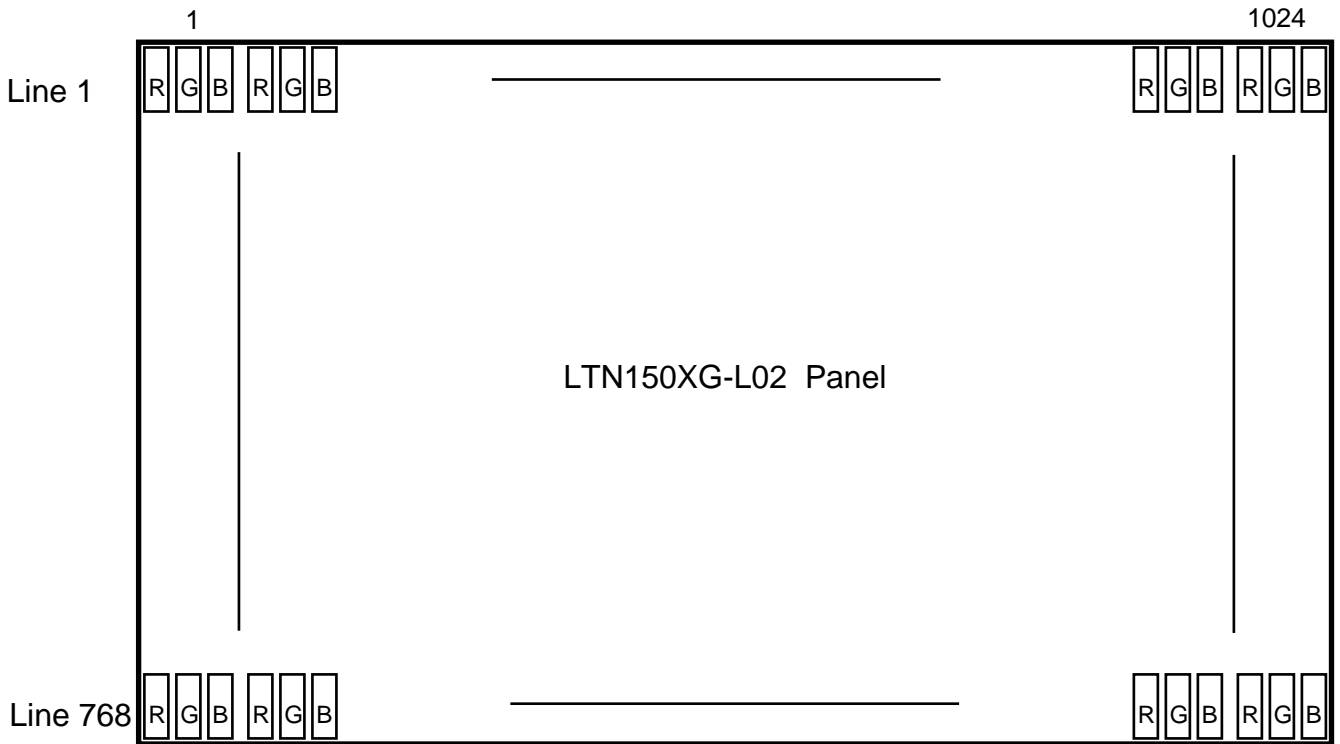

**Samsung Secret**

## 6. INTERFACE TIMING

### 6.1 Timing Parameters

Signal	Item	Symbol	Min.	Typ.	Max.	Unit	Note
Frame Frequency	Cycle	$T_V$	-	806		Lines	-
Vertical Active Display Term	Display Period	$T_{VD}$	-	768	-	Lines	-
One Line Scanning Time	Cycle	$T_H$		1344		Clocks	-
Horizontal Active Display Term	Display Period	$T_{HD}$	-	1024	-	Clocks	-
Horizontal Back porch		$T_{hbp}$	-	320	-	Clocks	-
Horizontal Front porch		$T_{hfp}$	-	24	-	Clocks	-
Vertical Back porch		$T_{vbp}$	-	38	-	Lines	-
Vertical Front porch		$T_{vfp}$	-	3	-	Lines	-

### 6.2 Timing diagrams of interface signal

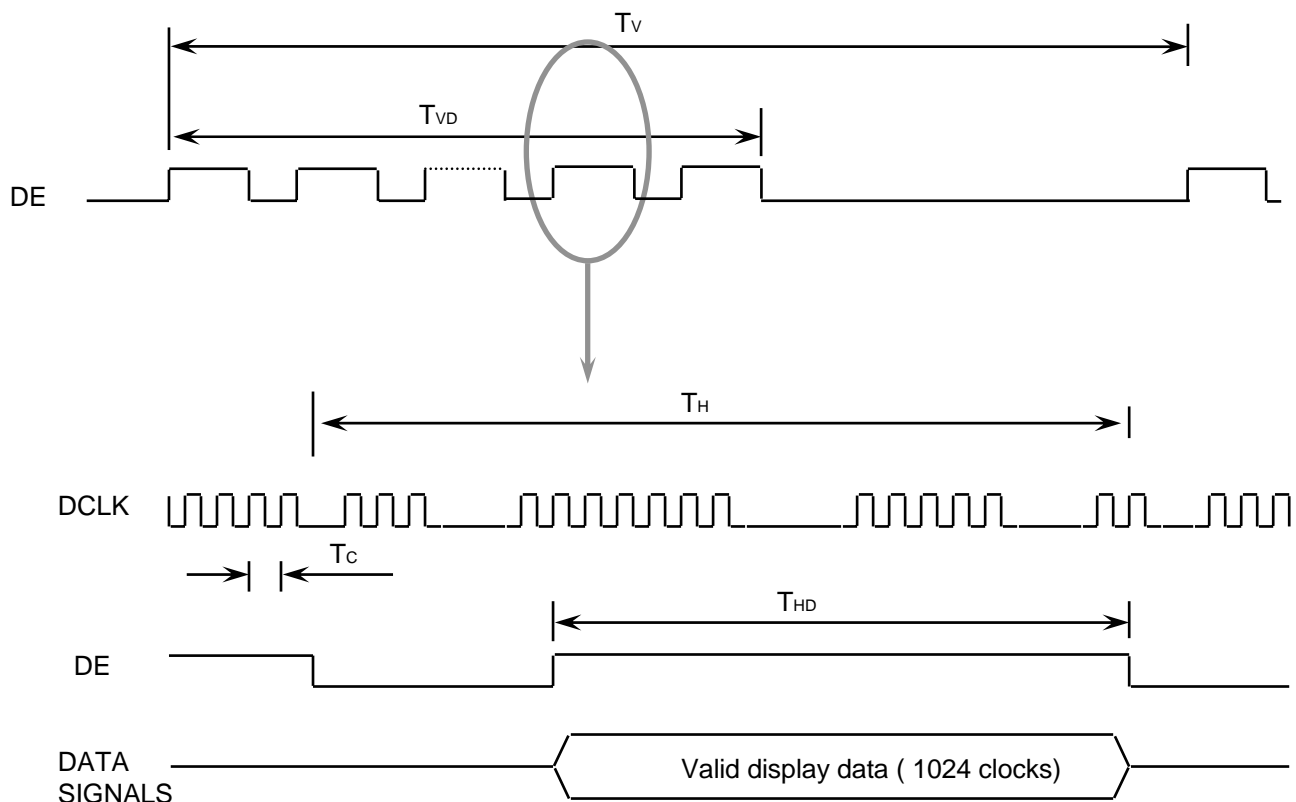

**Samsung Secret**

### 6.3 Power ON/OFF Sequence

Approval

: To prevent a latch-up or DC operation of the LCD module, the power on/off sequence should be as the diagram below.

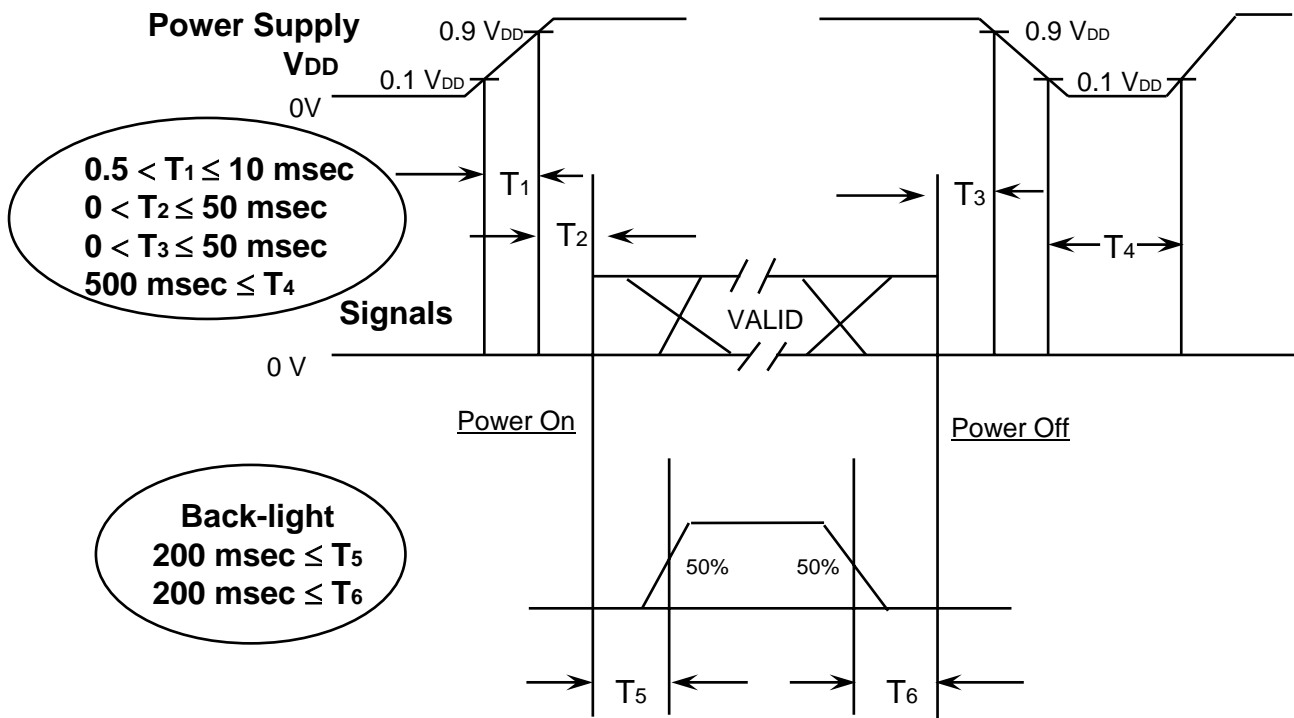

Power ON/OFF Sequence

- T1 : Vdd rising time from 10% to 90%
- T2 : The time from Vdd to valid data at power ON.
- T3 : The time from valid data off to Vdd off at power Off.
- T4 : Vdd off time for Windows restart
- T5 : The time from valid data to B/L enable at power ON.
- T6 : The time from valid data off to B/L disable at power Off.

**NOTE.**

- (1) The supply voltage of the external system for the module input should be the same as the definition of  $V_{DD}$ .
- (2) Apply the lamp voltage within the LCD operation range. When the back-light turns on before the LCD operation or the LCD turns off before the back-light turns off, the display may momentarily become white.
- (3) In case of  $V_{DD}$  = off level, please keep the level of input signals on the low or keep a high impedance.
- (4) T4 should be measured after the module has been fully discharged between power off and on period.
- (5) Interface signal shall not be kept at high impedance when the power is on.

**Samsung Secret**

## 7. MECHANICAL OUTLINE DIMENSION

Approval

[ Refer to the next page ]

**Samsung Secret**



## 8. PACKING

### 8.1 Packing

CARTON(Internal Package)

#### (1)Packing Form

Corrugated fiberoard box and corrugated cardboard as shock absorber

#### (2)Packing Method

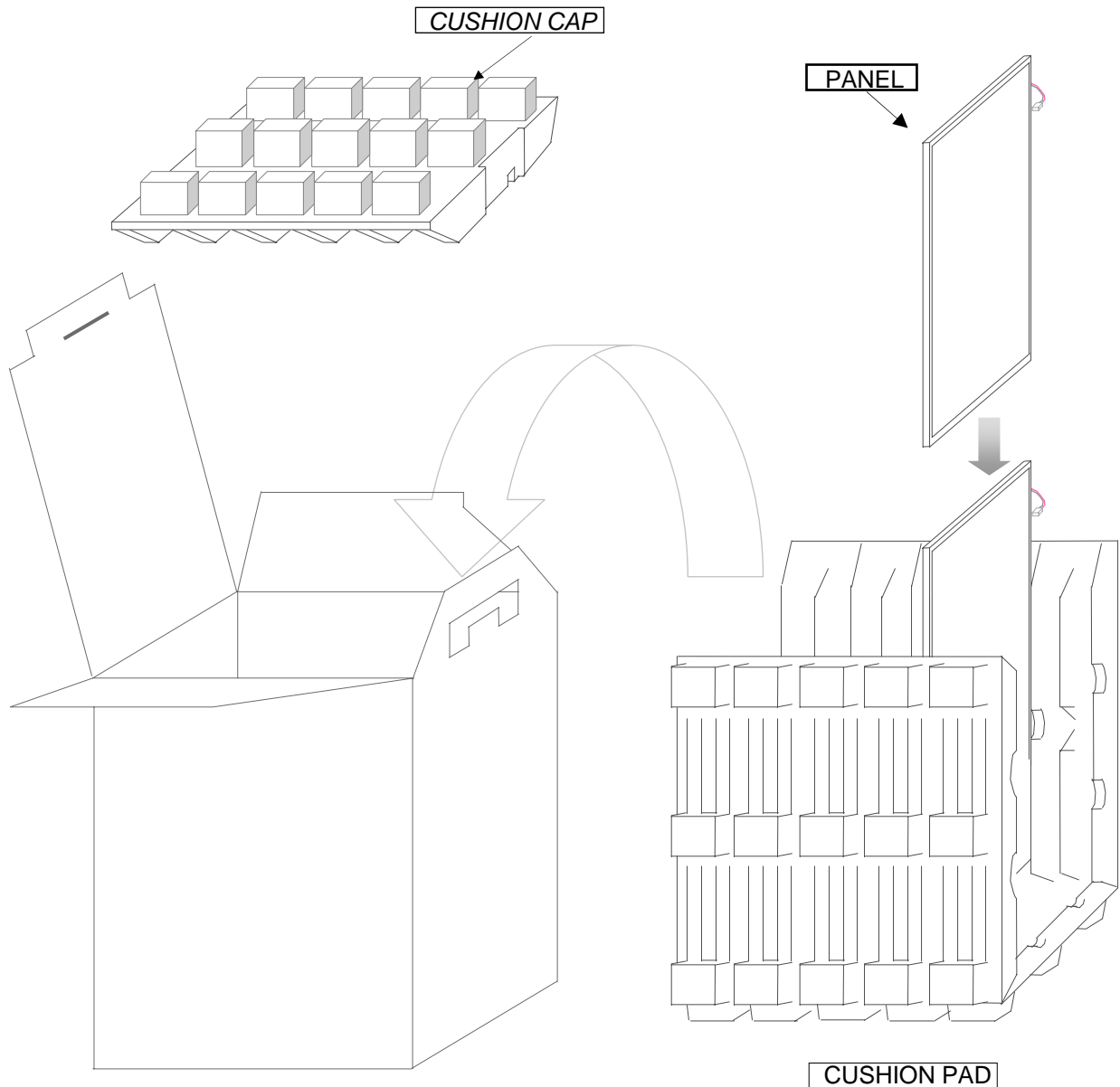

Note (1)Total : Approx. 7.5Kg

(2)Acceptance number of piling : 10 sets

(3)Carton size : 325(W) X 260(D) X 420(H)

**Samsung Secret**



(3)Packing Material

No.	Parts name	Quantity
1	Static electric protective sack	10
2	Cushion pad (Inner box) Included shock absorber	1set
3	Pictorial marking	2 pics
4	Carton	1 set

**9. MARKINGS & OTHERS**

A nameplate bearing followed by is affixed to a shipped product at the specified location on each product.

- (1)Parts number : LTN150XG-L02
- (2)Revision : Three letters
- (3)Control code : One letter
- (4)Lot number : X X X XXX XX XX XXX

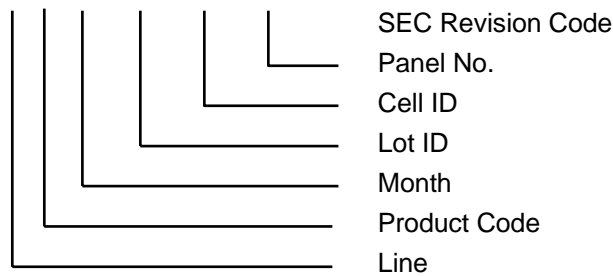

(5) Nameplate Indication

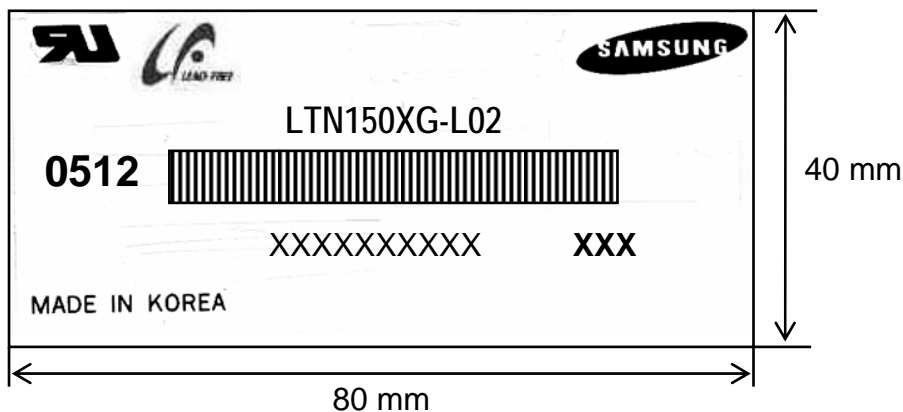

Parts name : LTN150XG - L02  
 Lot number : XXXXXXXXXXXX  
 Inspected work week : 0512(Year 2005, 12th week)  
 Product Revision Code : XXX

**Samsung Secret**

High voltage caution notice

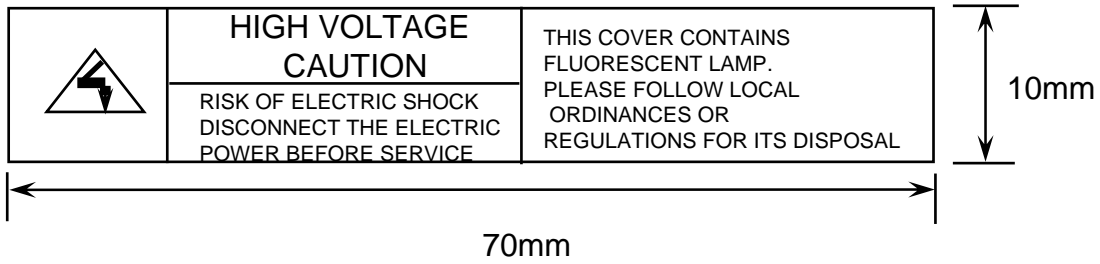

(6) Packing small box attach

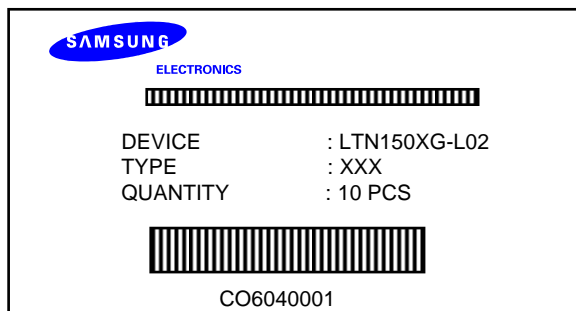

(7) Packing box Marking : Samsung TFT-LCD Brand Name



Samsung Secret

## 10. GENERAL PRECAUTIONS

Approval

### 1. Handling

- (a) When the module is assembled, It should be attached to the system firmly using every mounting holes. Be careful not to twist and bend the modules.
- (b) Refrain from strong mechanical shock and / or any force to the module. In addition to damage, this may cause improper operation or damage to the module and CCFT back-light.
- (c) Note that polarizers are very fragile and could be easily damaged. Do not press or scratch the surface harder than a HB pencil lead.
- (d) Wipe off water droplets or oil immediately. If you leave the droplets for a long time, Staining and discoloration may occur.
- (e) If the surface of the polarizer is dirty, clean it using some absorbent cotton or soft cloth.
- (f) The desirable cleaners are water, IPA (Isopropyl Alcohol) or Hexane. Do not use Ketone type materials(ex. Acetone), Ethyl alcohol, Toluene, Ethyl acid or Methyl chloride. It might permanent damage to the polarizer due to chemical reaction.
- (g) If the liquid crystal material leaks from the panel, it should be kept away from the eyes or mouth. In case of contact with hands, legs or clothes, it must be washed away thoroughly with soap.
- (h) Protect the module from static, it may cause damage to the C-MOS Gate Array IC.
- (i) Use fingerstalls with soft gloves in order to keep display clean during the incoming inspection and assembly process.
- (j) Do not disassemble the module.
- (k) Do not pull or fold the lamp wire.
- (l) Do not adjust the variable resistor which is located on the back side.
- (m) Protection film for polarizer on the module shall be slowly peeled off just before use so that the electrostatic charge can be minimized.
- (n) Pins of I/F connector shall not be touched directly with bare hands.

**Samsung Secret**

## 2. STORAGE

- (a) Do not leave the module in high temperature, and high humidity for a long time.  
It is highly recommended to store the module with temperature from 0 to 35 °C and relative humidity of less than 70%.
- (b) Do not store the TFT-LCD module in direct sunlight.
- (c) The module shall be stored in a dark place. It is prohibited to apply sunlight or fluorescent light during the store.

## 3. OPERATION

- (a) Do not connect, disconnect the module in the “ Power On” condition.
- (b) Power supply should always be turned on/off by following item 6.3  
“ Power on/off sequence “.
- (c) Module has high frequency circuits. Sufficient suppression to the electromagnetic interference shall be done by system manufacturers. Grounding and shielding methods may be important to minimize the interference.
- (d) The cable between the back-light connector and its inverter power supply shall be a minimized length and be connected directly . The longer cable between the back-light and the inverter may cause lower luminance of lamp(CCFT) and may require higher startup voltage (Vs).
- (e) The standard limited warranty is only applicable when the module is used for general notebook applications. If used for purposes other than as specified, SEC is not to be held reliable for the defective operations. It is strongly recommended to contact SEC to find out fitness for a particular purpose.

## 4. OTHERS

- (a) Ultra-violet ray filter is necessary for outdoor operation.
- (b) Avoid condensation of water. It may result in improper operation or disconnection of electrode.
- (c) Do not exceed the absolute maximum rating value. ( the supply voltage variation, input voltage variation, variation in part contents and environmental temperature, so on)  
Otherwise the module may be damaged.
- (d) If the module displays the same pattern continuously for a long period of time, it can be the situation when the image “sticks” to the screen.

**Samsung Secret**

# 11. EDID

Approval

Address (HEX)	FUNCTION	Value	BIN	DEC	ASCII or Data	Notes
		HEX				
00	Header	00	00000000	0		EDID Header
01		FF	11111111	255		
02		FF	11111111	255		
03		FF	11111111	255		
04		FF	11111111	255		
05		FF	11111111	255		
06		FF	11111111	255		
07		00	00000000	0		
08	ID Manufacturer Name	4C	01001100	76	S	3 character ID
09		A3	10100011	163	E C	"SEC"
0A	ID Product Code	47	01000111	71	G	
0B		32	00110010	50	2	
0C	32-bit serial no.	00	00000000	0		
0D		00	00000000	0		
0E		00	00000000	0		
0F		00	00000000	0		
10	Week of manufacture	00	00000000	0		
11	Year of manufacture	0D	00001101	13	2003	2003
12	EDID Structure Ver.	01	00000001	1	1	EDID Ver. 1.0
13	EDID revision #	03	00000011	3	3	EDID Rev. 0.3
14	Video input definition	80	10000000	128		
15	Max H image size	1E	00011110	30	30	30.4128cm
16	Max V image size	17	00010111	23	23	22.8096cm
17	Display Gamma	78	01111000	120	2.2	Gamma 2.2
18	Feature support	0A	00001010	10		
19	Red/green low bits	AD	10101101	173		10101101
1A	Blue/white low bits	75	01110101	117		01110101
1B	Red x/ high bits	90	10010000	144	0.564	Red x 0.564= 1001001110
1C	Red y	55	01010101	85	0.334	Red y 0.334= 0101011110
1D	Green x	52	01010010	82	0.323	Green x 0.323= 0101001011
1E	Green y	87	10000111	135	0.530	Green y 0.530= 1000100001
1F	Blue x	26	00100110	38	0.150	Blue x 0.150= 0010011101
20	Blue y	21	00100001	33	0.132	Blue y 0.132= 0010000111
21	White x	50	01010000	80	0.313	White x 0.313= 0101000001
22	White y	54	01010100	84	0.329	White y 0.329= 0101010001
23	Established timing 1	00	00000000	0		
24	Established timing 2	00	00000000	0		
25	Established timing 3	00	00000000	0		

**Samsung Secret**

26	Standard timing #1	01	00000001	1		not used	
27		01	00000001	1			
28	Standard timing #2	01	00000001	1		not used	
29		01	00000001	1			
2A	Standard timing #3	01	00000001	1		not used	
2B		01	00000001	1			
2C	Standard timing #4	01	00000001	1		not used	
2D		01	00000001	1			
2E	Standard timing #5	01	00000001	1		not used	
2F		01	00000001	1			
30	Standard timing #6	01	00000001	1		not used	
31		01	00000001	1			
32	Standard timing #7	01	00000001	1		not used	
33		01	00000001	1			
34	Standard timing #8	01	00000001	1		not used	
35		01	00000001	1			
36	Detailed timing/monitor descriptor #1	64	01100100	100	65	main clock=65 Mhz	
37		19	00011001	25			
38		00	00000000	0	1024	Hor active=1024 pixels	
39		40	01000000	64	320	Hor blanking=320 pixels	
3A		41	01000001	65		4bit : 4bit	
3B		00	00000000	0	768	Vertical active=768 lines	
3C		26	00100110	38	38	Vertical blanking=38lines	
3D		30	00110000	48		4bit : 4bit	
3E		18	00011000	24	24	Hor sync. Offset=24 pixels	
3F		88	10001000	136	136	H sync. Width=136 pixels	
40		Detailed timing/monitor descriptor #1	36	00110110	54	3	V sync. Offset=3 lines
						6	V sync. Width=6 lines
41			00	00000000	0		2bit : 2bit :2bit :2bit
42			30	00110000	48	304	H image size= 304.128 mm(approx)
43			E4	11100100	228	228	V image size = 228.096 mm(approx)
44			10	00010000	16		
45			00	00000000	0		No Horizontal Border
46		00	00000000	0		No Vertical Border	
47		19	00011001	25			
48	Detailed timing/monitor descriptor #2	00	00000000	0		Manufacturer Specified (Timing)	
49		00	00000000	0			
4A		00	00000000	0			
4B		0F	00001111	15			
4C		00	00000000	0		Value=HSPWmin / 2	
4D		04	00000100	4		Value=HSPWmax / 2	
4E		7E	01111110	126		Value=Thbpmin / 2	
4F		18	00011000	24		Value=Thbpmax / 2	
50		FF	11111111	255		Value=VSPWmin / 2	
51		01	00000001	1		Value=VSPWmax / 2	
52		05	00000101	5		Value=Tvbpmin / 2	
53		02	00000010	2		Value=Tvbpmax / 2	
54		6F	01101111	111		Thpmin=value*2 + Hapixelclks	
55		18	00011000	24		Thpmax=value*2 + Hapixelclks	
56		FF	11111111	255		Tvpmin=value*2 + Valines	
57		02	00000010	2		Tvpmax=value*2 + Valines	
58		74	01110100	116			
59		00	00000000	0	0	Module revision	

Samsung Secret

5A	Detailed timing/monitor descriptor #3	00	00000000	0		ASCII Data String Tag
5B		00	00000000	0		
5C		00	00000000	0		
5D		FE	11111110	254		
5E		00	00000000	0		
5F		53	01010011	83	[S]	
60		41	01000001	65	[A]	
61		4D	01001101	77	[M]	
62		53	01010011	83	[S]	
63		55	01010101	85	[U]	
64		4E	01001110	78	[N]	
65		47	01000111	71	[G]	
66		0A	00001010	10	[^]	
67		20	00100000	32	[ ]	
68		20	00100000	32	[ ]	
69	20	00100000	32	[ ]		
6A	20	00100000	32	[ ]		
6B	20	00100000	32	[ ]		
6C	Detailed timing/monitor descriptor #4	00	00000000	0		Monitor Name Tag (ASCII)
6D		00	00000000	0		
6E		00	00000000	0		
6F		FE	11111110	254		
70		00	00000000	0		
71		4C	01001100	76	[L]	
72		54	01010100	84	[T]	
73		4E	01001110	78	[N]	
74		31	00110001	49	[1]	
75		35	00110101	53	[5]	
76		30	00110000	48	[0]	
77		58	01011000	88	[X]	
78		47	01000111	71	[G]	
79		2D	00101101	45	[-]	
7A		4C	01001100	76	[L]	
7B	30	00110000	48	[0]		
7C	32	00110010	50	[2]		
7D	0A	00001010	10	[^]		
7E	Extension Flag	00	00000000	0		
7F	Checksum	9C	10011100	156		

Samsung Secret