



SmarterGlass

state-of-the-art display solutions

www.smarterglass.com
978 997 4104
sales@smarterglass.com

SPEC. NO.	TQ3C-8EAF0-E1DDN04-01
DATE	March 28, 2006

FOR :

TYPE: TCG104VG2AA-G00

CONTENTS

1. Application
2. Construction and Outline
3. Mechanical Specifications
4. Absolute Maximum Ratings
5. Electrical Characteristics
6. Optical Characteristics
7. Interface Signals
8. Timing Characteristics of input signals
9. Backlight Characteristics
10. Lot Number Identification
11. Warranty
12. Precautions for Use
13. Reliability Data/Environmental Test
14. Outline Drawing

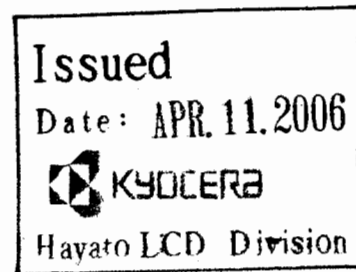

KYOCERA CORPORATION
KAGOSHIMA HAYATO PLANT
LCD DIVISION

This specification is subject to change without notice.
Consult Kyocera before ordering.

Original	Designed by :Engineering Dept.			Confirmed by :QA Dept.	
Issue Date	Prepared	Checked	Approved	Checked	Approved
January 14, 2006	<i>J. Yamazaki</i>	<i>H. Tokumoto</i>	<i>M. Fujitani</i>	<i>Y. Matsumoto</i>	<i>S. Hayashi</i>

Caution

1. This Kyocera LCD module has been specifically designed for use only in electronic devices in the areas of audio control, office automation, industrial control, home appliances, etc. The modules should not be used in applications where module failure could result in physical harm or loss of life, and Kyocera expressly disclaims any and all liability relating in any way to the use of the module in such applications.
2. Customer agrees to indemnify, defend and hold Kyocera harmless from and against any and all actions, claims, losses, damages, liabilities, awards, costs, and expenses, including legal fees, resulting from or arising out of Customer's use, or sale for use, of Kyocera modules in applications.
3. Kyocera shall have the right, which Customer hereby acknowledges, to immediately scrap or destroy tooling for Kyocera modules for which no Purchase Orders have been received from the Customer in a two-year period.

Revision Record

Date		Designed by: Engineering Dept.			Confirmed by: QA Dept.	
		Prepared	Checked	Approved	Checked	Approved
March 28, 2006		<i>J. Yamazaki</i>	<i>H. Tokumori</i>	<i>M. Fujitani</i>	<i>Y. Matsumoto</i>	<i>S. Hayashi</i>
Rev. No.	Date	Page	Descriptions			
01	March 28, 2006	6	6. Optical Characteristics Add "Brightness uniformity"			
		7	"6-3. Definition of ..." Change "The brightness is measuring...." Add "The brightness uniformity"			
		8	7-1. LCD Change "LCD side connector" "Recommended matching connector" 7-2. CFL Change "Recommended matching connector"			
		9	8-1. Timing characteristics Change "Horizontal sync. signal" Change "Vertical sync. signal"			
		14	14. Outline drawing Change outline drawing			

1. Application

This data sheet defines the specification for a $(640 \times R.G.B) \times 480$ dot, amorphous silicon TFT transmissive color dot matrix type Liquid Crystal Display with CFL backlight.

『RoHS Compliant』

2. Construction and Outline

$(640 \times R.G.B) \times 480$ dots, COG type LCD with CFL backlight.

Backlight system : Side-edge type CFL (2 tubes).

Inverter : Option.
Recommended Inverter : CXA-0308 (TDK)

Polarizer : Glare treatment.

Additional circuits : Timing controller, Power supply (3.3V/5.0V input)

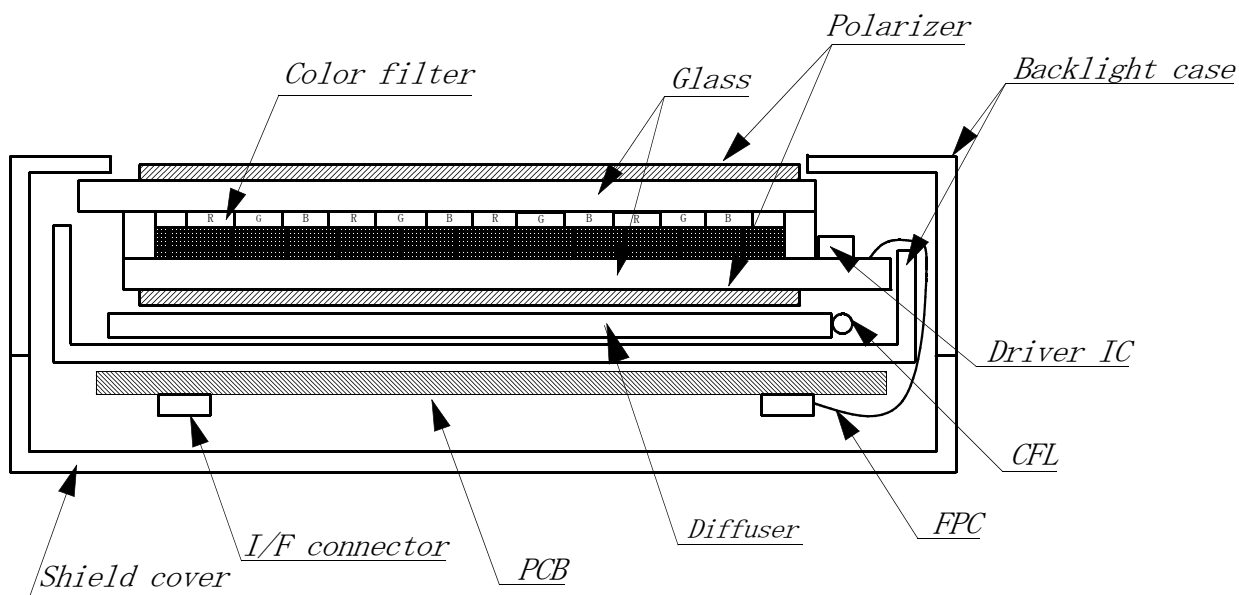

This drawing is showing conception only.

3. Mechanical Specifications

ITEM	SPECIFICATION	UNIT
Outline dimensions	243 (W) × 185.1 (H) × 10.5 (D)	mm
Effective viewing area	213.2 (W) × 160.4 (H)	mm
Dot number	(640×R. G. B) (W) × 480 (H)	Dots
Dot pitch	0.11 (W) × 0.33 (H)	mm
Display mode *1	Normally Black	—
Mass	(520)	g

*1 Due to the characteristics of the LCD material, the color vary with environmental temperature.

4. Absolute Maximum Ratings

4-1. Electrical absolute maximum ratings

ITEM	SYMBOL	Min.	Max.	UNIT
Power input voltage	VDD	-0.3	6.0	V
Input signal voltage *1	Vin	-0.3	VDD + 0.3	V

*1 Input signals : CK, Hsync, Vsync, R0~R5, G0~G5, B0~B5, DE, SC

4-2. Environmental absolute maximum ratings

ITEM	SYMBOL	Min.	Max.	UNIT
Operating temperature *1	Top	-10	70	deg. C
Storage temperature *2	Tsto	-20	80	deg. C
Operating humidity *3	Hop	10	*4	%RH
Storage humidity *3	Hsto	10	*4	%RH
Vibration	—	*5	*5	—
Shock	—	*6	*6	—

*1 Operating temperature means a temperature which operation shall be guaranteed.
Since display performance is evaluated at 25 deg.C, another temperature range should be confirmed.

*2 Temp. = -20 °C < 48 h , Temp = 80 °C < 168 h
Store LCD panel at normal temperature/humidity.
Keep it free from vibration and shock.
LCD panel that is kept at low or high temperature for a long time can be defective due to the other conditions, even if the temperature satisfies standard.
(Please refers to 12. Precautions for use as detail).

*3 Non-condensation.

*4 Temp. ≤ 40 deg.C, 85%RH Max.
Temp. > 40 deg.C, Absolute Humidity shall be less than 85% RH at 40 deg.C.

*5

Frequency	10~55 Hz	Converted to acceleration value : (0.3~9 m/s ²)
Vibration width	0.15 mm	
Interval	10-55-10 Hz 1 minute	

2 hours in each direction X/Y/Z (6 hours as total)
EIAJ ED-2531

*6 Acceleration: 490m/s²
Pulse width : 11 ms
3 times in each direction : ±X/±Y/±Z.
EIAJ ED-2531

5. Electrical Characteristics
 5-1. LCD Electrical Characteristics

Temp. = 25°C

ITEM	SYMBOL	MIN	TYP	MAX	UNIT
Power supply voltage	VDD	3.0	3.3 / 5.0	5.25	V
Power supply current *2	White (a)	—	(495)	—	mA
	Black (b)	—	(450)	—	
	Vertical Stripe (c)	—	(563)	—	
Permissive input ripple voltage	VRP	—	—	(100)	mV
Rush current *1	IRUSH	—	—	(1)	A
Input signal voltage (Low)	VIL	—	—	0.3VDD	V
Input signal voltage (High)	VIH	0.7VDD	—	VDD	V

* The module is recommended to operate within specification ranges listed above for normal function.

*1 Measurement Conditions :

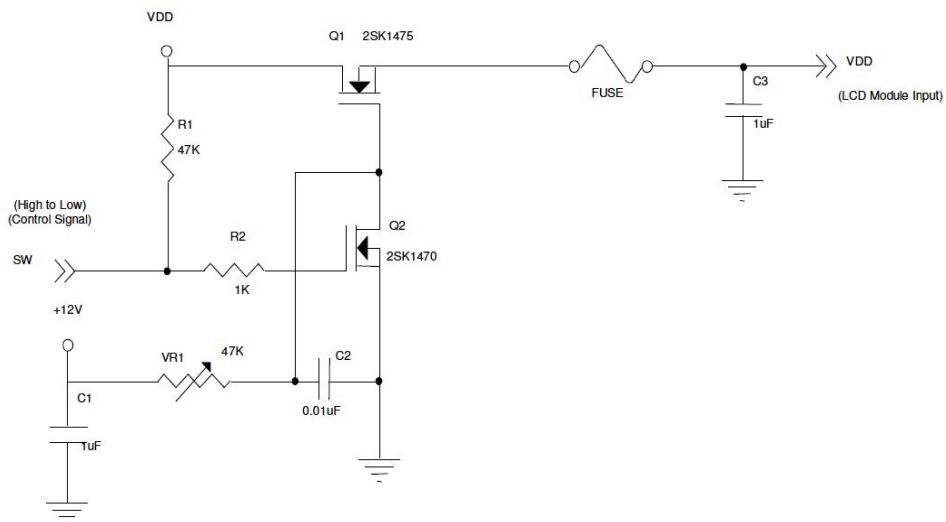

VDD rising time

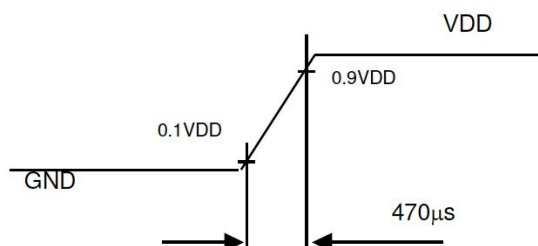

*2 The specified power supply current is under the conditions at VDD = 3.3V, Ta = 25°C, Fr = 60Hz

a. White Pattern



b. Black Pattern



c. Vertical Stripe Pattern

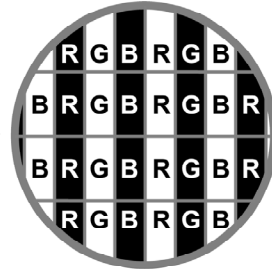
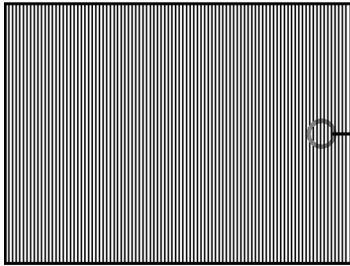

5-2. Supply Voltage Sequence Condition

To prevent a latch-up or DC operation of LCD module, the power on/off sequence should be as the diagram below.

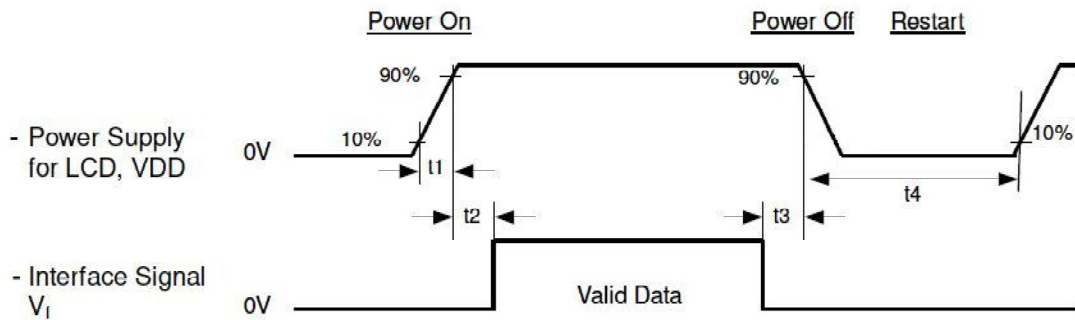

- * Timing Characteristics
- $0.5 < t1 \leq 10\text{ms}$
- $0 < t2 \leq 50\text{ms}$
- $0 < t3 \leq 50\text{ms}$
- $t4 \geq 500\text{ms}$

* Control the supply voltage sequence not to float all signal line when the LCD panel is driving.

6. Optical Characteristics

Measuring points = ϕ 6.0mm , Temp. = 25°C

ITEM		SYMBOL	CONDITION	MIN	TYP	MAX	UNIT	
Response time	Rise	τr	$\theta = \phi = 0^\circ$	—	(14)	—	ms	
	Down	τd	$\theta = \phi = 0^\circ$	—	(9)	—	ms	
Viewing angle range		θ	$CR \geq 5$	Upper	—	(85)	—	deg.
				Lower	—	(85)	—	
		ϕ		Left	—	(85)	—	deg.
				Right	—	(85)	—	
Contrast ratio		CR	$\theta = \phi = 0^\circ$	(600)	(750)	—	—	
Brightness		L	IL=5.0mArms.	(360)	(450)	—	cd/m ²	
Brightness uniformity		LU	—	(70)	—	—	%	
Chromaticity coordinates	Red	x	$\theta = \phi = 0^\circ$	(TBD)	(TBD)	(TBD)	—	
		y		(TBD)	(TBD)	(TBD)		
	Green	x	$\theta = \phi = 0^\circ$	(TBD)	(TBD)	(TBD)		
		y		(TBD)	(TBD)	(TBD)		
	Blue	x	$\theta = \phi = 0^\circ$	(TBD)	(TBD)	(TBD)		
		y		(TBD)	(TBD)	(TBD)		
	White	x	$\theta = \phi = 0^\circ$	(TBD)	(TBD)	(TBD)		
		y		(TBD)	(TBD)	(TBD)		

6-1. Contrast ratio is defined as follows:

$$CR = \frac{\text{Brightness at all pixels "White"}}{\text{Brightness at all pixels "Black"}}$$

6-2. Definition of viewing angle

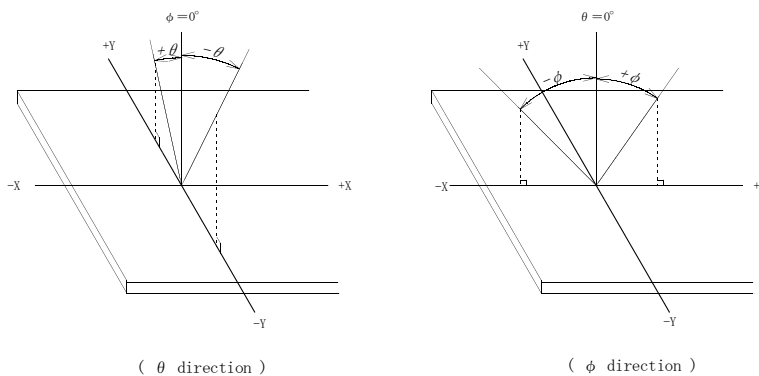

6-3. Definition of brightness and brightness uniformity

The brightness is measuring by white brightness at center of display screen(3).

The brightness uniformity is calculated by using following formula.

$$\text{Brightness uniformity} = \frac{\text{Minimum brightness from 1 to 5}}{\text{Maximum brightness from 1 to 5}} \times 100 [\%]$$

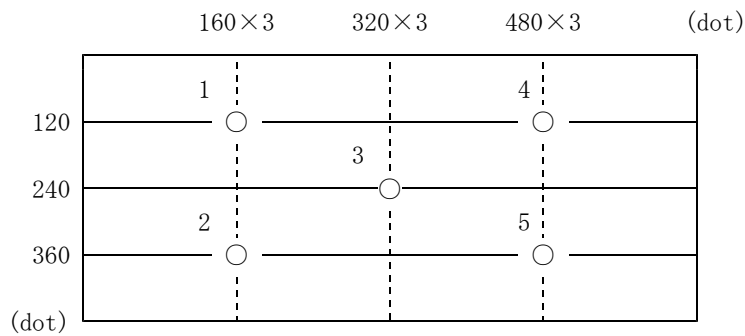

- 1) Rating is defined as the average brightness inside the viewing area.
- 2) 30 minutes after CFL is turned on. (Ambient Temp.=25°C)
- 3) The inverter should meet the CFL rating conditions;
 - Sine, symmetric waveform without spike in positive and negative.

7. Interface signals

7-1. LCD

CM1

PIN NO.	SYMBOL	DESCRIPTION	I/O	Note
1	GND	GND	-	
2	CK	Clock signal for sampling each data signal	I	
3	Hsync	Horizontal synchronous signal (negative)	I	
4	Vsync	Vertical synchronous signal (negative)	I	
5	GND	GND	-	
6	R0	RED data signal (LSB)	I	
7	R1	RED data signal	I	
8	R2	RED data signal	I	
9	R3	RED data signal	I	
10	R4	RED data signal	I	
11	R5	RED data signal (MSB)	I	
12	GND	GND	-	
13	G0	GREEN data signal (LSB)	I	
14	G1	GREEN data signal	I	
15	G2	GREEN data signal	I	
16	G3	GREEN data signal	I	
17	G4	GREEN data signal	I	
18	G5	GREEN data signal (MSB)	I	
19	GND	GND	-	
20	B0	BLUE data signal (LSB)	I	
21	B1	BLUE data signal	I	
22	B2	BLUE data signal	I	
23	B3	BLUE data signal	I	
24	B4	BLUE data signal	I	
25	B5	BLUE data signal (MSB)	I	
26	GND	GND	-	
27	DE	Signal to settle the horizontal display position(positive)	I	
28	VDD	power supply(+3.3V/+5.0V)	-	
29	VDD	power supply(+3.3V/+5.0V)	-	
30	NC	No connect	I	*1
31	SC	Scan direction control (GND or Open : normal, High : Reverse)	I	*2

LCD side connector : DF9C-31P-1V(32) (HIROSE)
 Recommended matching connector : DF9-31S-1V, DF9A-31S-1V(32) (HIROSE)
 DF9B-31S-1V(32), DF9C-31S-1V(32) (HIROSE)

* The shield case is connected with GND.

*1 Do not input any signal at Pin No.30(Open state). It might happen LCD has a trouble.

*2 Scanning Direction

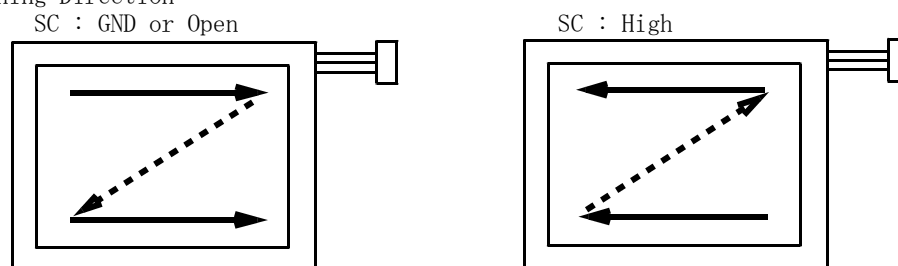

7-2. CFL

CN2

PIN NO.	SYMBOL	DESCRIPTION
1	COLD	Inverter output low voltage side
2	HOT	Inverter output High voltage side
3	HOT	Inverter output High voltage side

LCD side connector : BHR-03VS-1 (JST)
 Recommended matching connector : SM03(4.0)B-BHS-1TB (JST)
 : SM03(4.0)B-BHS-1-TB(LF)(SN) (JST) . . . (RoHS)

* Please be careful NOT to connect inversely an inverter-output high voltage side to the CFL low voltage side. It may result in damage or electric shock.

8. Timing Characteristics of input signals

8-1. Timing characteristics

ITEM	SYMBOL	MIN	TYP	MAX	UNIT	NOTE	
Clock	Frequency	1/Tc	(21)	(25.175)	(29)	MHz	
	Duty ratio	—	(0.4)	(0.5)	(0.6)	—	
Data	Set up time	Tds	(8)	—	—	ns	
	Hold time	Tdh	(12)	—	—	ns	
Horizontal sync. signal	Cycle	TH	(690)	(800)	(1,279)	clock	*1
	Display	THd	(640)	(640)	(640)	clock	
	Blank	THb	(80)	(160)	(TH-THd)	clock	
Vertical sync. signal	Frame frequency	Fr	(56)	(60)	(75)	Hz	
	Cycle	TV	(482)	(525)	(959)	line	*2
	Display	TVd	(480)	(480)	(480)	line	
	Blank	TVb	(2)	(45)	(TV-TVd)	line	

* In case of lower frequency, the deterioration of the display quality, flicker etc., may occur.

*1 $TH = THd + THb$

*2 $TV = TVd + TVb$

*3 Input signal timing diagram

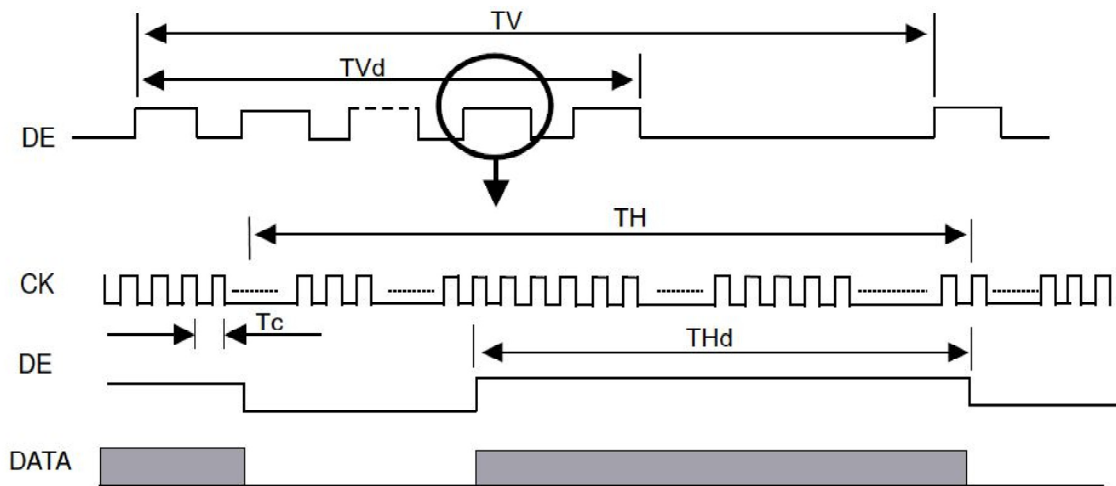

8-2. Block diagram

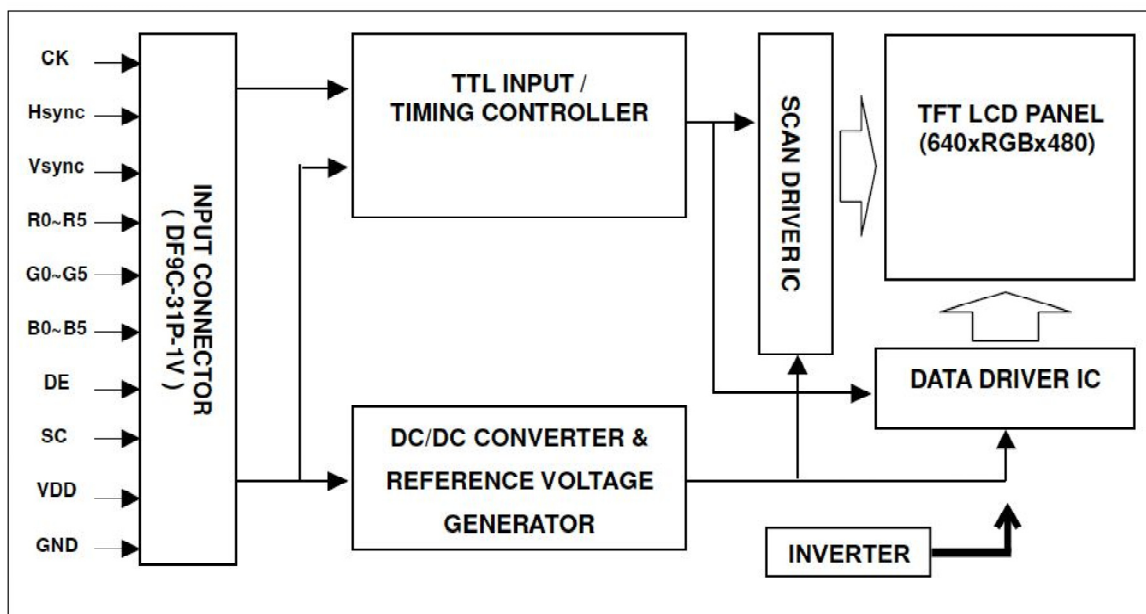

9. Backlight Characteristics

Temp. = 25°C

ITEM	SYMBOL	MIN.	TYP.	MAX.	NOTE
Starting discharge Voltage *1	VS	—	—	(1,325) Vrms.	-10 °C
		—	—	(830) Vrms.	25 °C
Discharging tube current *2	IL	(2.0) mArms.	(5.0) mArms.	(6.0) mArms.	—
Discharging tube voltage	VL	—	(490) Vrms.	—	IL=5.0mArms.
Operating life *3	T	(36,000) h	(50,000) h	—	IL=5.0mArms.
Operating frequency *4	F	(40) kHz	—	(100) kHz	—

*1 The Non-load output voltage (VS) of the inverter should be designed to have some margin, because VS may increase due to the leak current which may be caused by wiring of CFL cables. (Reference value : (1,720) Vrms Min.)

*2 We recommend that you should set the discharging tube current at lower than typical value so as to prevent the heat accumulation of CFL tube from deteriorating a performance of the LCD.

*3 End of life is defined as when the illuminance or quantity of light has decreased to 50% of the initial value. Illuminance of light will drastically decrease when LCD is operated at lower temperature for long hours.

*4 The driving frequency of the CFL may interfere with the horizontal synchronous signal, leaving interference stripes on the display. So please evaluate LCD panels beforehand. To avoid interference stripes, we recommend to separate as far as possible the CFL frequency from the horizontal synchronous signal and its high harmonic frequency.

* There may be cases where interface noise on LCD PCB, generated by high-voltage products such as inverters, may leave stripes on the display. Please be careful when designing a mold to take into consideration that the inverter shall be located as far as possible from PCB. Shield protection may be effective.

1 0. Lot Number Identification

The lot number shall be indicated on the back of the backlight case of each LCD.

TCG104VG2AA-G00 - □ □ - □ □ - □ MADE IN □ □ □ □ □

↓ ↓ ↓ ↓ ↓
 ① ② ③ ④ ⑤

- ①YEAR
- ②MONTH
- ③DATE
- ④Version Number
- ⑤Country of origin(Japan or China)

YEAR	2006	2007	2008	2009	2010	2011
CODE	6	7	8	9	0	1

MONTH	JAN.	FEB.	MAR.	APR.	MAY.	JUN.
CODE	1	2	3	4	5	6

MONTH	JUL.	AUG.	SEP.	OCT.	NOV.	DEC.
CODE	7	8	9	X	Y	Z

1 1. Warranty

11-1. Incoming inspection

Please inspect the LCD within one month after your receipt.

11-2. Production Warranty

Kyocera warrants its LCDs for a period of 12 months after receipt by the purchaser, and within the limits specified. Kyocera shall, by mutual agreement, replace or rework defective LCDs that are shown to be Kyocera's responsibility.

1 2. Precautions for use

12-1. Installation of the LCD

1. A transparent protection sheet shall be added to protect the LCD and its polarizers.
2. The LCD shall be installed so that there is no pressure on the LSI chips.
3. The LCD shall be installed flat, without twisting or bending.
4. The display window size should be the same as the effective viewing area.
5. In case you use outside frame of effective viewing area as outward appearance of your product, unevenness of its outward appearance is out of guarantee.
6. Do not pull the CFL lead wires and do not bend the root of the wires.
Housing should be designed to protect CFL lead wires from external stress.

12-2. Static Electricity

1. Since CMOS ICs are mounted directly onto the LCD glass, protection from static electricity is required. Operator should wear ground straps.

12-3. LCD Operation

1. The LCD shall be operated within the limits specified. Operation at values outside of these limits may shorten life, and/or harm display images.
2. Operation of the LCD at temperature below the limit specified may cause image degradation and/or bubbles.
It may also change the characteristics of the liquid crystal.
This phenomenon may not recover. The LCD shall be operated within the temperature limits specified.

12-4. Storage

1. The LCD shall be stored within normal temperature and humidity.
Store in a dark area, and protected the LCD from direct sunlight or fluorescent light.
2. Always store the LCD so that it is free from external pressure onto it.

12-5. Screen Surface

1. DO NOT store in a high humidity environment for extended periods.
Image degradation, bubbles, and/or peeling off of polarizer may result.
2. The front polarizer is easily scratched or damaged.
Prevent touching it with any hard material, and from being pushed or rubbed.
3. The LCD screen may be cleaned with a soft cloth or cotton pad.
Methanol, or Isopropyl Alcohol may be used, but insure that all solvent residue is removed.
4. Water may cause damage or discoloration of the polarizer.
Clean any condensation or moisture from any source immediately.
5. Always keep the LCD free from condensation during testing.
Condensation may permanently spot or stain the polarizers.
6. Do not disassemble LCD module because it will result in damage.
7. Please do not use solid-base image pattern for long hours because a temporary afterimage may appear. We recommend to use screen saver etc. in cases where a solid-base image pattern must be used.
8. A transparent protection sheet is attached to the polarizer. Please remove the protection film slowly before use, paying attention to static electricity.
9. This Kyocera LCD module has been specifically designed for use in general electronic devices, but not for use in a special environment such as usage in an active gas.
Hence, when the LCD is supposed to be used in a special environment, evaluate the LCD thoroughly beforehand and do not expose the LCD to chemicals such as an active gas.

1 3. Reliability Data / Environmental Test

TEST ITEM	TEST CONDITION	TEST TIME	RESULT
High Temp. Atmosphere	80°C	240 h	Display Quality : T.B.D. Display Function : T.B.D. Current Consumption : T.B.D.
Low Temp. Atmosphere	-30°C	240 h	Low Temp. Bubble : T.B.D. Solid Crystallization of Liquid Crystal : T.B.D. Display Quality : T.B.D. Display Function : T.B.D. Current Consumption : T.B.D.
High Temp. Humidity Operation	60°C 90 %RH	240 h	Display Quality : T.B.D. Display Function : T.B.D. Peel-off of Organic Sealing : T.B.D. Current Consumption : T.B.D.
Temp. Cycle	-30°C 0.5 h R.T. 0.5 h 80°C 0.5 h	10 cycles	Display Quality : T.B.D. Display Function : T.B.D. Peel-off of Organic Sealing : T.B.D. Bubble on Cell : T.B.D.
High Temp. Operation	70°C	500 h	Display Quality : T.B.D. Current Consumption : T.B.D.

* Each test item uses a test LCD only once. The tested LCD is not used in any other tests.

* The LCD is tested in circumstances in which there is no condensation.

* The tested LCD is inspected after 24 hours of storage at room temperature and room humidity after each test is finished.

* The reliability test is not an out-going inspection.

* The results of the reliability test are for your reference purpose only.
The reliability test is conducted only to examine the LCD's capability.

No	Description	Drawn	Checked	Checked	Approved

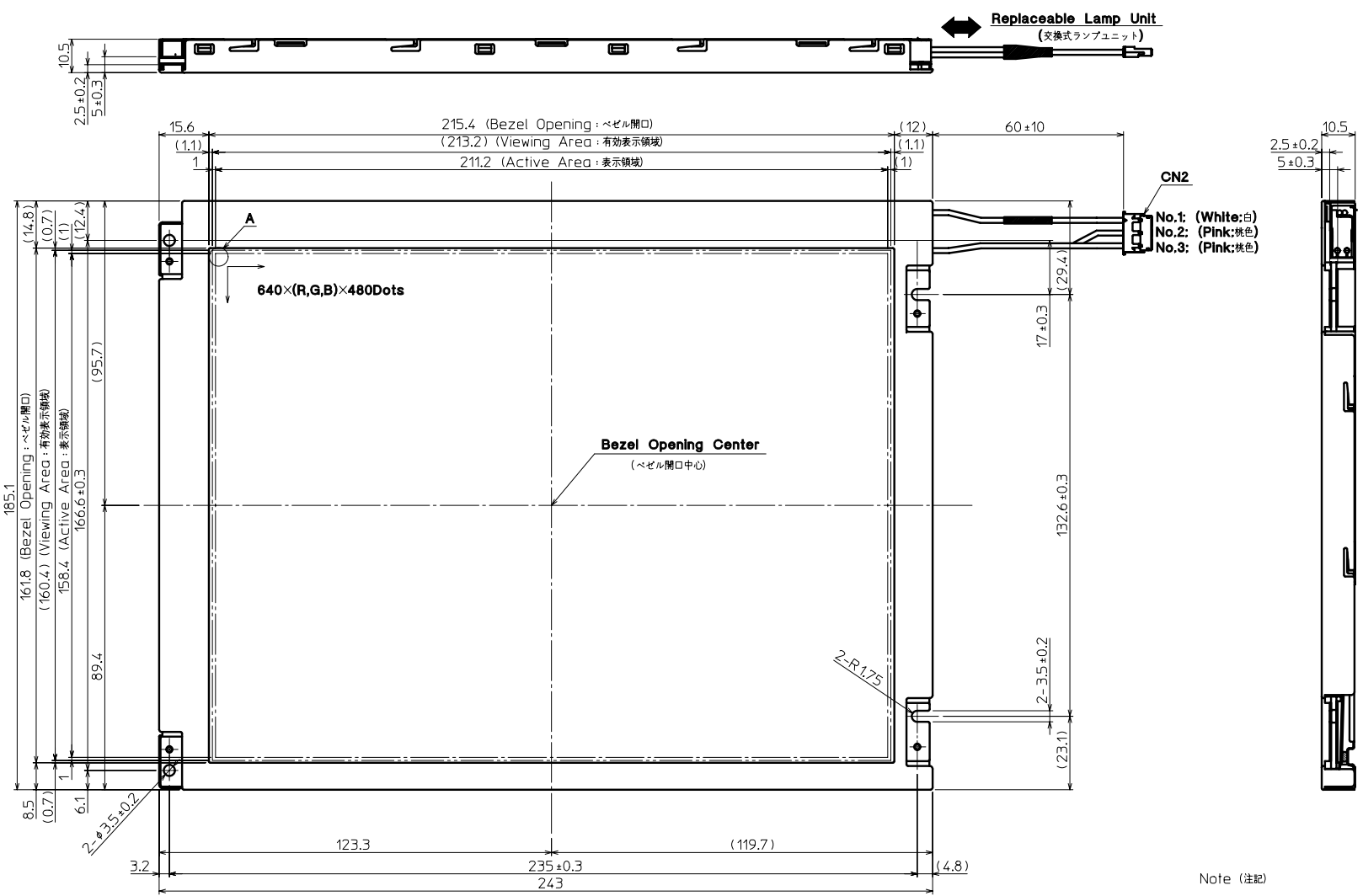

Note (注記)

- Connector CN1: DF9C-31P-1V(32) (HIROSE) (コネクタ)
CN2: BHR-03VS-1 (JST)
- Matching Connector CN1: DF9×-31S-1V (HIROSE) (適合コネクタ)
CN2: SM03(4.0)B-BHS-1-TB (JST)
SM03(4.0)B-BHS-1-TB-(LF)(SN) (JST)
- The Information of LCD is displayed starting at the lower right hand corner, moving left then up to the upper left hand corner.
(LCDにおいて、画像データの表示は右下コーナーから始まり、左へ進み上へ送られ左上コーナーへ向かう。)
4 Tolerance without indication: ±0.5 (指示無き公差)

Material 材質	Treatment 処理	Approved '06.03.15	Checked '06.03.09	Checked '06.03.09	Drawn 茶園	Scale 1:1 (NTS)	Title TCG104VG2AA	KYOCERA Year-Month-Day '06.03.09	Size 2
Quantity 製作数	Description: 備考	朝倉	阿部	今村	茶園	Outline Dimensions	Drawing No. 121A5047600		

No	Description	Drawn	Checked	Checked	Approved

Contrast Adjustment Volume
(ボリューム調整孔)

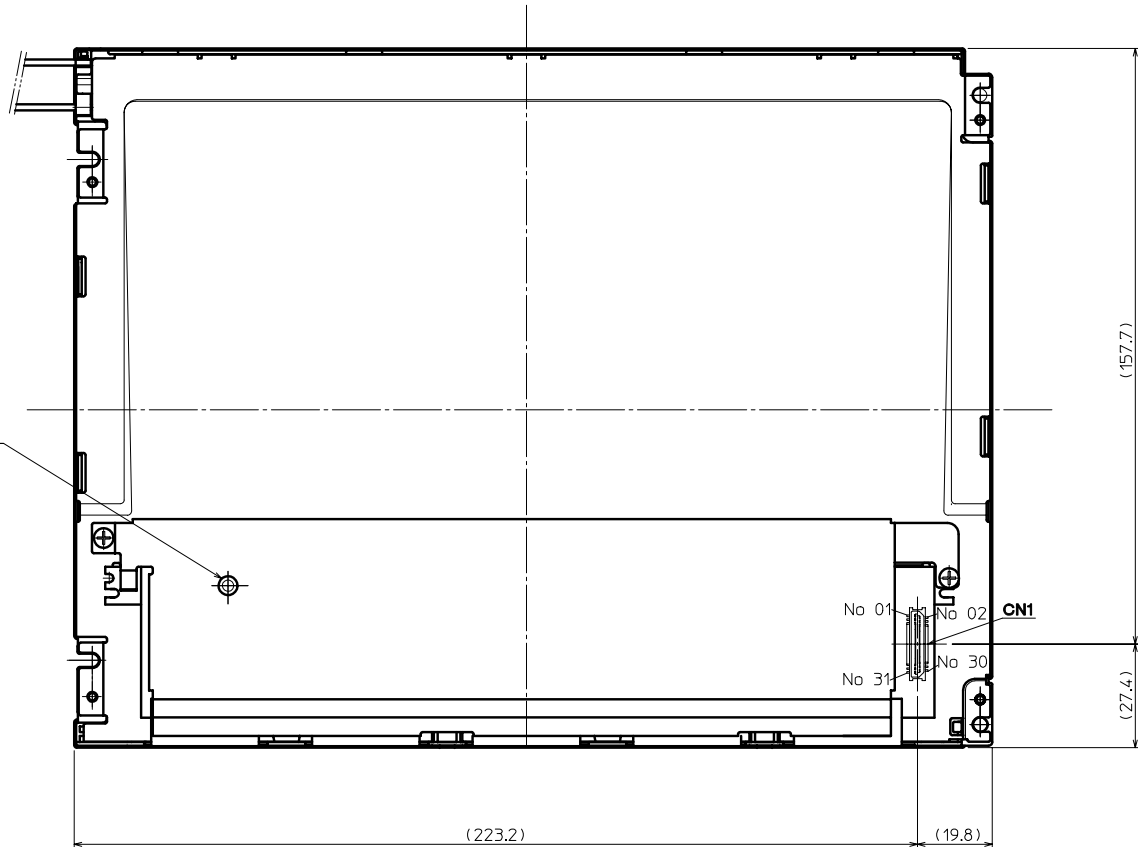

Material 材質	Treatment 処理	Approved '06.03.15	Checked '06.03.09	Checked '06.03.09	Drawn 茶園	Scale 1:1 (NTS)	Title TCG104VG2AA	Year-Month-Day '06.03.09	Size 2
Quantity 製作数	Description: 備考 RoHS	朝倉	阿部	今村	茶園		Outline Dimensions	RoHS	2
							Drawing No. 121A5047600	2/2	

SPEC. NO.	TQ3C-8EAF0-E2DDN04-00
DATE	January 14, 2006

FOR : _____

KYOCERA INSPECTION STANDARD

TYPE : TCG104VG2AA-G00

KYOCERA CORPORATION
 KAGOSHIMA HAYATO PLANT
 LCD DIVISION

Original	Designed by :Engineering Dept.			Confirmed by :QA Dept.	
Issue Date	Prepared	Checked	Approved	Checked	Approved
January 14, 2006	<i>Y. Yamazaki</i>	<i>H. Tokumori</i>	<i>M. Fujitani</i>	<i>Y. Matsumoto</i>	<i>S. Higashi</i>

Revision Record

Date	Designed by: Engineering Dept.			Confirmed by: QA Dept.	
	Prepared	Checked	Approved	Checked	Approved
Rev. No.	Date	Page	Descriptions		

1) Note

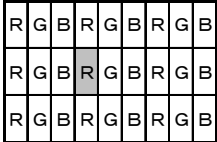
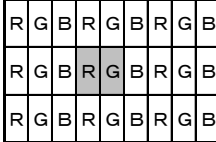
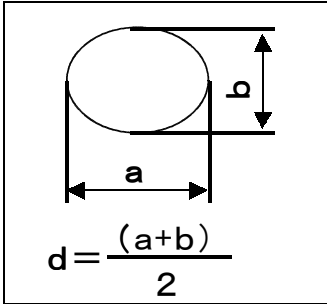
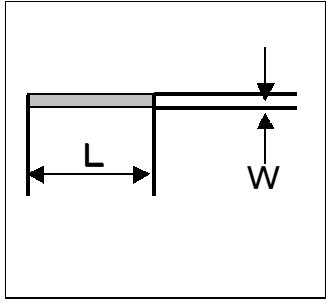
		Note		
General	<p>1. Customer identified anomalies not defined within this inspection standard shall be reviewed by Kyocera, and an additional standard shall be determined by mutual consent.</p> <p>2. Inspection Conditions Luminance : 500 Lux minimum Inspection distance : 300 mm (from the sample) Temperature : 25 ± 5 °C Direction : directly above</p>			
Definition of Inspection item	Dot defect	Bright dot defect	<p>The dot is constantly "on" when power applied to the LCD, even when all "Black" data sent to the screen. Inspection tool: 5% Transparency neutral density filter. Count dot: If the dot is visible through the filter Don't count dot: If the dot is not visible through the filter.</p>  <p style="text-align: right;">■ dot defect</p>	
		Black dot defect	<p>The dot is constantly "off" when power applied to the LCD, even when all "white" data sent to the screen.</p>	
		Adjacent dot	<p>Adjacent dot defect is defined as two or more bright dot defects or black dot defects.</p>  <p style="text-align: right;">■ dot defect</p>	
	External inspection	Bubble, Scratches, Foreign particle (Polarizer, Cell, Backlight)	Visible operating (all pixels "Black" or "White") and non operating.	
		Appearance inspection	Does not satisfy the value at the spec.	
	Others	CFL wires	Damaged to the CFL wires, connector, pin, functional failure or appearance failure.	
	Definition of size	<p>Definition of circle size</p>  <p style="text-align: center;">$d = \frac{(a+b)}{2}$</p>	<p>Definition of linear size</p> 	

2) Standard

Classification		Inspection item		Judgement standard																	
defect (in LCD glass)	Dot defect	Bright dot defect		Acceptable number : 4 bright dots defects Bright dot spacing : 5 mm or more																	
		Black dot defect		Acceptable number : 5 black dots defects Black dot spacing : 5 mm or more																	
		2 dots join	Bright dot defect	Acceptable number : 2																	
			Black dot defect	Acceptable number : 3																	
		3 or more dots join		Acceptable number : 0																	
	Total dot defects		Acceptable number : 5 Max																		
	Others	White dot, Dark dot (Circle)		<table border="1"> <thead> <tr> <th>Size(mm)</th> <th colspan="2">Acceptable Number</th> </tr> </thead> <tbody> <tr> <td>d < 0.2</td> <td colspan="2">(neglected)</td> </tr> <tr> <td>0.2 < d ≤ 0.4</td> <td colspan="2">5</td> </tr> <tr> <td>0.4 < d ≤ 0.5</td> <td colspan="2">3</td> </tr> <tr> <td>0.5 < d</td> <td colspan="2">0</td> </tr> </tbody> </table>			Size(mm)	Acceptable Number		d < 0.2	(neglected)		0.2 < d ≤ 0.4	5		0.4 < d ≤ 0.5	3		0.5 < d	0	
Size(mm)	Acceptable Number																				
d < 0.2	(neglected)																				
0.2 < d ≤ 0.4	5																				
0.4 < d ≤ 0.5	3																				
0.5 < d	0																				
External inspection (Defect on Polarizer or between Polariz- er and LCD glass)	Polarizer(Scratches)			<table border="1"> <thead> <tr> <th>Width(mm)</th> <th>Length(mm)</th> <th>Acceptable Number</th> </tr> </thead> <tbody> <tr> <td>W ≤ 0.1</td> <td>-</td> <td>(neglected)</td> </tr> <tr> <td rowspan="2">0.1 < W ≤ 0.3</td> <td>L ≤ 5.0</td> <td>(neglected)</td> </tr> <tr> <td>5.0 < L</td> <td>0</td> </tr> <tr> <td>0.3 < W</td> <td>-</td> <td>0</td> </tr> </tbody> </table>			Width(mm)	Length(mm)	Acceptable Number	W ≤ 0.1	-	(neglected)	0.1 < W ≤ 0.3	L ≤ 5.0	(neglected)	5.0 < L	0	0.3 < W	-	0	
		Width(mm)	Length(mm)	Acceptable Number																	
		W ≤ 0.1	-	(neglected)																	
		0.1 < W ≤ 0.3	L ≤ 5.0	(neglected)																	
	5.0 < L		0																		
	0.3 < W	-	0																		
	Polarizer Touch panel (Bubble, Dent)			<table border="1"> <thead> <tr> <th>Size(mm)</th> <th colspan="2">Acceptable Number</th> </tr> </thead> <tbody> <tr> <td>d < 0.2</td> <td colspan="2">(neglected)</td> </tr> <tr> <td>0.2 < d ≤ 0.3</td> <td colspan="2">5</td> </tr> <tr> <td>0.3 < d ≤ 0.5</td> <td colspan="2">3</td> </tr> <tr> <td>0.5 < d</td> <td colspan="2">0</td> </tr> </tbody> </table>			Size(mm)	Acceptable Number		d < 0.2	(neglected)		0.2 < d ≤ 0.3	5		0.3 < d ≤ 0.5	3		0.5 < d	0	
		Size(mm)	Acceptable Number																		
		d < 0.2	(neglected)																		
		0.2 < d ≤ 0.3	5																		
	0.3 < d ≤ 0.5	3																			
	0.5 < d	0																			
	Foreign Particle(Circular shape)			<table border="1"> <thead> <tr> <th>Size(mm)</th> <th colspan="2">Acceptable Number</th> </tr> </thead> <tbody> <tr> <td>d < 0.2</td> <td colspan="2">(neglected)</td> </tr> <tr> <td>0.2 < d ≤ 0.4</td> <td colspan="2">5</td> </tr> <tr> <td>0.4 < d ≤ 0.5</td> <td colspan="2">3</td> </tr> <tr> <td>0.5 < d</td> <td colspan="2">0</td> </tr> </tbody> </table>			Size(mm)	Acceptable Number		d < 0.2	(neglected)		0.2 < d ≤ 0.4	5		0.4 < d ≤ 0.5	3		0.5 < d	0	
		Size(mm)	Acceptable Number																		
		d < 0.2	(neglected)																		
		0.2 < d ≤ 0.4	5																		
0.4 < d ≤ 0.5	3																				
0.5 < d	0																				
Foreign Particle (Linear shape), Scratches			<table border="1"> <thead> <tr> <th>Width(mm)</th> <th>Length(mm)</th> <th>Acceptable Number</th> </tr> </thead> <tbody> <tr> <td>W ≤ 0.03</td> <td>-</td> <td>(neglected)</td> </tr> <tr> <td rowspan="3">0.03 < W ≤ 0.1</td> <td>L ≤ 2.0</td> <td>(neglected)</td> </tr> <tr> <td>2.0 < L ≤ 4.0</td> <td>3</td> </tr> <tr> <td>4.0 < L</td> <td>0</td> </tr> <tr> <td>0.1 < W</td> <td>-</td> <td>(According to Circular shape)</td> </tr> </tbody> </table>			Width(mm)	Length(mm)	Acceptable Number	W ≤ 0.03	-	(neglected)	0.03 < W ≤ 0.1	L ≤ 2.0	(neglected)	2.0 < L ≤ 4.0	3	4.0 < L	0	0.1 < W	-	(According to Circular shape)
	Width(mm)	Length(mm)	Acceptable Number																		
	W ≤ 0.03	-	(neglected)																		
	0.03 < W ≤ 0.1	L ≤ 2.0	(neglected)																		
		2.0 < L ≤ 4.0	3																		
4.0 < L		0																			
0.1 < W	-	(According to Circular shape)																			