



SmarterGlass

state-of-the-art display solutions

www.smarterglass.com
978 997 4104
sales@smarterglass.com

HITACHI

KAOHSIUNG HITACHI
ELECTRONICS CO.,LTD
P.O. BOX 26-27
2,13TH EAST ST. K.E.P.Z.
KAOHSIUNG TAIWAN R.O.C.
TEL:(07) 821-5811(7 LINE)
FAX:(07) 821-5815

FOR MESSRS : _____

DATE : Apr.18,2005

CUSTOMER'S ACCEPTANCE SPECIFICATIONS

TX16D11VM2CAA

CONTENTS

No.	ITEM	SHEET No.	PAGE
1	COVER	7B64PS 2701-TX16D11VM2CAA-3	1-1/1
2	RECORD OF REVISION	7B64PS 2702-TX16D11VM2CAA-3	2-1/2~2/2
3	GENERAL DATA	7B64PS 2703-TX16D11VM2CAA-3	3-1/1
4	ABSOLUTE MAXIMUM RATINGS	7B64PS 2704-TX16D11VM2CAA-3	4-1/1
5	ELECTRICAL CHARACTERISTICS	7B64PS 2705-TX16D11VM2CAA-3	5-1/3~3/3
6	OPTICAL CHARACTERISTICS	7B64PS 2706-TX16D11VM2CAA-3	6-1/3~3/3
7	BLOCK DIAGRAM	7B64PS 2707-TX16D11VM2CAA-3	7-1/1
8	INTERFACE TIMING CHART	7B64PS 2708-TX16D11VM2CAA-3	8-1/6~6/6
9	DIMENSIONAL OUTLINE	7B63PS 2709-TX16D11VM2CAA-3	9-1/2~9-2/2
10	APPEARANCE STANDARD	7B64PS 2710-TX16D11VM2CAA-3	10-1/5~5/5
11	PRECAUTION IN DESIGN	7B64PS 2711-TX16D11VM2CAA-3	11-1/4~4/4
12	DESIGNATION OF LOT MARK	7B64PS 2712-TX16D11VM2CAA-3	12-1/1
13	PRECAUTION FOR USE	7B64PS 2713-TX16D11VM2CAA-3	13-1/1

*When product will be discontinued, customer will be informed by HITACHI with twelve months prior announcement.

ACCEPTED BY: _____

PROPOSED BY: Jay Yang

KAOHSIUNG HITACHI ELECTRONICS CO.,LTD.	Sh. No.	7B64PS 2701-TX16D11VM2CAA-3	PAGE	1-1/1
---	------------	-----------------------------	------	-------

RECORD OF REVISION

DATE	SHEET No.	SUMMARY																																																																																																																																																																						
Oct.22,'03	7B64PS 2703- TX16D11VM2CAA-2 Page 3-1/2	3. GENERATE DATA Added : (10) Average life time 50kh at 25°C IL=5mA Added : (15) Viewing direction.																																																																																																																																																																						
	7B64PS 2708- TX16D11VM2CAA-2 Page 8-6/6	8. INTERNAL PIN CONNECTION Changed CN2 pin No. <table border="1" style="width: 100%; border-collapse: collapse; margin-top: 10px;"> <tr> <td style="width: 5%; text-align: center;">1</td> <td style="width: 20%;">VSS</td> <td style="width: 5%; text-align: center;">-</td> <td style="width: 70%;">GND for CFL</td> </tr> <tr> <td style="text-align: center;">2</td> <td>VCFL</td> <td style="text-align: center;">-</td> <td>Power Supply for CFL</td> </tr> </table>	1	VSS	-	GND for CFL	2	VCFL	-	Power Supply for CFL																																																																																																																																																														
	1	VSS	-	GND for CFL																																																																																																																																																																				
	2	VCFL	-	Power Supply for CFL																																																																																																																																																																				
7B64PS 2709- TX16D11VM2CAA-2 Page 9-1/2	9. DIMENSIONAL OUTINE Changed the pin definition of CN2. <div style="text-align: center; margin-top: 10px;"> </div>																																																																																																																																																																							
7B64PS 2711- TX16D11VM2CAA-2 Page 11-4/4	11.5 MOUNTING PRECAUTION Added : LCM assemble explanation.																																																																																																																																																																							
Apr.12,'05	7B64PS 2706- TX16D11VM2CAA-3 Page 6-1/3	6.1 OPTICAL CHARACTERISTICS OF LCD Revised: <table border="1" style="width: 100%; border-collapse: collapse; margin-bottom: 10px;"> <thead> <tr> <th colspan="2">ITEM</th> <th>CONDITION</th> <th>MIN.</th> <th>TYP.</th> <th>MAX</th> <th>UNIT</th> <th>NOTE</th> </tr> </thead> <tbody> <tr> <td rowspan="4" style="text-align: center; vertical-align: middle;">Viewing Area</td> <td>θx</td> <td>$\phi = 0^\circ, K \geq 5.0$</td> <td style="text-align: center;">-</td> <td style="text-align: center;">(60)</td> <td style="text-align: center;">-</td> <td style="text-align: center;">deg</td> <td style="text-align: center;">1~5</td> </tr> <tr> <td>$\theta x'$</td> <td>$\phi = 180^\circ, K \geq 5.0$</td> <td style="text-align: center;">-</td> <td style="text-align: center;">(60)</td> <td style="text-align: center;">-</td> <td style="text-align: center;">deg</td> <td style="text-align: center;">1~5</td> </tr> <tr> <td>θy</td> <td>$\phi = 90^\circ, K \geq 5.0$</td> <td style="text-align: center;">-</td> <td style="text-align: center;">(45)</td> <td style="text-align: center;">-</td> <td style="text-align: center;">deg</td> <td style="text-align: center;">1~5</td> </tr> <tr> <td>$\theta y'$</td> <td>$\phi = 270^\circ, K \geq 5.0$</td> <td style="text-align: center;">-</td> <td style="text-align: center;">(60)</td> <td style="text-align: center;">-</td> <td style="text-align: center;">deg</td> <td style="text-align: center;">1~5</td> </tr> <tr> <td rowspan="8" style="text-align: center; vertical-align: middle;">Color Tone (Primary Color)</td> <td rowspan="2" style="text-align: center; vertical-align: middle;">Red</td> <td style="text-align: center;">x</td> <td rowspan="8" style="text-align: center; vertical-align: middle;">$\phi = 0^\circ, \theta = 0^\circ$</td> <td style="text-align: center;">-</td> <td style="text-align: center;">(0.62)</td> <td style="text-align: center;">-</td> <td style="text-align: center;">-</td> </tr> <tr> <td style="text-align: center;">y</td> <td style="text-align: center;">-</td> <td style="text-align: center;">(0.34)</td> <td style="text-align: center;">-</td> <td style="text-align: center;">-</td> </tr> <tr> <td rowspan="2" style="text-align: center; vertical-align: middle;">Green</td> <td style="text-align: center;">x</td> <td style="text-align: center;">-</td> <td style="text-align: center;">(0.30)</td> <td style="text-align: center;">-</td> <td style="text-align: center;">-</td> </tr> <tr> <td style="text-align: center;">y</td> <td style="text-align: center;">-</td> <td style="text-align: center;">(0.59)</td> <td style="text-align: center;">-</td> <td style="text-align: center;">-</td> </tr> <tr> <td rowspan="2" style="text-align: center; vertical-align: middle;">Blue</td> <td style="text-align: center;">x</td> <td style="text-align: center;">-</td> <td style="text-align: center;">(0.14)</td> <td style="text-align: center;">-</td> <td style="text-align: center;">-</td> </tr> <tr> <td style="text-align: center;">y</td> <td style="text-align: center;">-</td> <td style="text-align: center;">(0.09)</td> <td style="text-align: center;">-</td> <td style="text-align: center;">-</td> </tr> <tr> <td rowspan="2" style="text-align: center; vertical-align: middle;">White</td> <td style="text-align: center;">x</td> <td style="text-align: center;">-</td> <td style="text-align: center;">(0.29)</td> <td style="text-align: center;">-</td> <td style="text-align: center;">-</td> </tr> <tr> <td style="text-align: center;">y</td> <td style="text-align: center;">-</td> <td style="text-align: center;">(0.31)</td> <td style="text-align: center;">-</td> <td style="text-align: center;">-</td> </tr> </tbody> </table> <div style="text-align: center; margin-bottom: 10px;">↓</div> <table border="1" style="width: 100%; border-collapse: collapse;"> <thead> <tr> <th colspan="2">ITEM</th> <th>CONDITION</th> <th>MIN.</th> <th>TYP.</th> <th>MAX</th> <th>UNIT</th> <th>NOTE</th> </tr> </thead> <tbody> <tr> <td rowspan="4" style="text-align: center; vertical-align: middle;">Viewing Area</td> <td>θx</td> <td>$\phi = 0^\circ, K \geq 5.0$</td> <td style="text-align: center;">-</td> <td style="text-align: center;">70</td> <td style="text-align: center;">-</td> <td style="text-align: center;">deg</td> <td style="text-align: center;">1~5</td> </tr> <tr> <td>$\theta x'$</td> <td>$\phi = 180^\circ, K \geq 5.0$</td> <td style="text-align: center;">-</td> <td style="text-align: center;">70</td> <td style="text-align: center;">-</td> <td style="text-align: center;">deg</td> <td style="text-align: center;">1~5</td> </tr> <tr> <td>θy</td> <td>$\phi = 90^\circ, K \geq 5.0$</td> <td style="text-align: center;">-</td> <td style="text-align: center;">60</td> <td style="text-align: center;">-</td> <td style="text-align: center;">deg</td> <td style="text-align: center;">1~5</td> </tr> <tr> <td>$\theta y'$</td> <td>$\phi = 270^\circ, K \geq 5.0$</td> <td style="text-align: center;">-</td> <td style="text-align: center;">70</td> <td style="text-align: center;">-</td> <td style="text-align: center;">deg</td> <td style="text-align: center;">1~5</td> </tr> <tr> <td rowspan="8" style="text-align: center; vertical-align: middle;">Color Tone (Primary Color)</td> <td rowspan="2" style="text-align: center; vertical-align: middle;">Red</td> <td style="text-align: center;">x</td> <td rowspan="8" style="text-align: center; vertical-align: middle;">$\phi = 0^\circ, \theta = 0^\circ$</td> <td style="text-align: center;">0.57</td> <td style="text-align: center;">0.62</td> <td style="text-align: center;">0.67</td> <td style="text-align: center;">-</td> </tr> <tr> <td style="text-align: center;">y</td> <td style="text-align: center;">0.29</td> <td style="text-align: center;">0.34</td> <td style="text-align: center;">0.39</td> <td style="text-align: center;">-</td> </tr> <tr> <td rowspan="2" style="text-align: center; vertical-align: middle;">Green</td> <td style="text-align: center;">x</td> <td style="text-align: center;">0.25</td> <td style="text-align: center;">0.30</td> <td style="text-align: center;">0.35</td> <td style="text-align: center;">-</td> </tr> <tr> <td style="text-align: center;">y</td> <td style="text-align: center;">0.54</td> <td style="text-align: center;">0.59</td> <td style="text-align: center;">0.64</td> <td style="text-align: center;">-</td> </tr> <tr> <td rowspan="2" style="text-align: center; vertical-align: middle;">Blue</td> <td style="text-align: center;">x</td> <td style="text-align: center;">0.09</td> <td style="text-align: center;">0.14</td> <td style="text-align: center;">0.19</td> <td style="text-align: center;">-</td> </tr> <tr> <td style="text-align: center;">y</td> <td style="text-align: center;">0.04</td> <td style="text-align: center;">0.09</td> <td style="text-align: center;">0.14</td> <td style="text-align: center;">-</td> </tr> <tr> <td rowspan="2" style="text-align: center; vertical-align: middle;">White</td> <td style="text-align: center;">x</td> <td style="text-align: center;">0.24</td> <td style="text-align: center;">0.29</td> <td style="text-align: center;">0.34</td> <td style="text-align: center;">-</td> </tr> <tr> <td style="text-align: center;">y</td> <td style="text-align: center;">0.26</td> <td style="text-align: center;">0.31</td> <td style="text-align: center;">0.36</td> <td style="text-align: center;">-</td> </tr> </tbody> </table>	ITEM		CONDITION	MIN.	TYP.	MAX	UNIT	NOTE	Viewing Area	θx	$\phi = 0^\circ, K \geq 5.0$	-	(60)	-	deg	1~5	$\theta x'$	$\phi = 180^\circ, K \geq 5.0$	-	(60)	-	deg	1~5	θy	$\phi = 90^\circ, K \geq 5.0$	-	(45)	-	deg	1~5	$\theta y'$	$\phi = 270^\circ, K \geq 5.0$	-	(60)	-	deg	1~5	Color Tone (Primary Color)	Red	x	$\phi = 0^\circ, \theta = 0^\circ$	-	(0.62)	-	-	y	-	(0.34)	-	-	Green	x	-	(0.30)	-	-	y	-	(0.59)	-	-	Blue	x	-	(0.14)	-	-	y	-	(0.09)	-	-	White	x	-	(0.29)	-	-	y	-	(0.31)	-	-	ITEM		CONDITION	MIN.	TYP.	MAX	UNIT	NOTE	Viewing Area	θx	$\phi = 0^\circ, K \geq 5.0$	-	70	-	deg	1~5	$\theta x'$	$\phi = 180^\circ, K \geq 5.0$	-	70	-	deg	1~5	θy	$\phi = 90^\circ, K \geq 5.0$	-	60	-	deg	1~5	$\theta y'$	$\phi = 270^\circ, K \geq 5.0$	-	70	-	deg	1~5	Color Tone (Primary Color)	Red	x	$\phi = 0^\circ, \theta = 0^\circ$	0.57	0.62	0.67	-	y	0.29	0.34	0.39	-	Green	x	0.25	0.30	0.35	-	y	0.54	0.59	0.64	-	Blue	x	0.09	0.14	0.19	-	y	0.04	0.09	0.14	-	White	x	0.24	0.29	0.34	-	y	0.26	0.31	0.36	-
ITEM		CONDITION	MIN.	TYP.	MAX	UNIT	NOTE																																																																																																																																																																	
Viewing Area	θx	$\phi = 0^\circ, K \geq 5.0$	-	(60)	-	deg	1~5																																																																																																																																																																	
	$\theta x'$	$\phi = 180^\circ, K \geq 5.0$	-	(60)	-	deg	1~5																																																																																																																																																																	
	θy	$\phi = 90^\circ, K \geq 5.0$	-	(45)	-	deg	1~5																																																																																																																																																																	
	$\theta y'$	$\phi = 270^\circ, K \geq 5.0$	-	(60)	-	deg	1~5																																																																																																																																																																	
Color Tone (Primary Color)	Red	x	$\phi = 0^\circ, \theta = 0^\circ$	-	(0.62)	-	-																																																																																																																																																																	
		y		-	(0.34)	-	-																																																																																																																																																																	
	Green	x		-	(0.30)	-	-																																																																																																																																																																	
		y		-	(0.59)	-	-																																																																																																																																																																	
	Blue	x		-	(0.14)	-	-																																																																																																																																																																	
		y		-	(0.09)	-	-																																																																																																																																																																	
	White	x		-	(0.29)	-	-																																																																																																																																																																	
		y		-	(0.31)	-	-																																																																																																																																																																	
ITEM		CONDITION	MIN.	TYP.	MAX	UNIT	NOTE																																																																																																																																																																	
Viewing Area	θx	$\phi = 0^\circ, K \geq 5.0$	-	70	-	deg	1~5																																																																																																																																																																	
	$\theta x'$	$\phi = 180^\circ, K \geq 5.0$	-	70	-	deg	1~5																																																																																																																																																																	
	θy	$\phi = 90^\circ, K \geq 5.0$	-	60	-	deg	1~5																																																																																																																																																																	
	$\theta y'$	$\phi = 270^\circ, K \geq 5.0$	-	70	-	deg	1~5																																																																																																																																																																	
Color Tone (Primary Color)	Red	x	$\phi = 0^\circ, \theta = 0^\circ$	0.57	0.62	0.67	-																																																																																																																																																																	
		y		0.29	0.34	0.39	-																																																																																																																																																																	
	Green	x		0.25	0.30	0.35	-																																																																																																																																																																	
		y		0.54	0.59	0.64	-																																																																																																																																																																	
	Blue	x		0.09	0.14	0.19	-																																																																																																																																																																	
		y		0.04	0.09	0.14	-																																																																																																																																																																	
	White	x		0.24	0.29	0.34	-																																																																																																																																																																	
		y		0.26	0.31	0.36	-																																																																																																																																																																	

RECORD OF REVISION

DATE	SHEET No.	SUMMARY								
Apr.12,'05	7B64PS 2706- TX16D11VM2CAA-3 Page 6-3/3	6.2 OPTICAL CHARACTERISTICS OF BACKLIGHT Revised: <table border="1" style="margin-left: auto; margin-right: auto; border-collapse: collapse;"> <tr> <td style="padding: 2px;">TIEM</td> <td style="padding: 2px;">TYP.</td> </tr> <tr> <td style="padding: 2px;">Brightness</td> <td style="padding: 2px;">(200)</td> </tr> </table> <p style="text-align: center;">↓</p> <table border="1" style="margin-left: auto; margin-right: auto; border-collapse: collapse;"> <tr> <td style="padding: 2px;">TIEM</td> <td style="padding: 2px;">TYP.</td> </tr> <tr> <td style="padding: 2px;">Brightness</td> <td style="padding: 2px;">(280)</td> </tr> </table>	TIEM	TYP.	Brightness	(200)	TIEM	TYP.	Brightness	(280)
TIEM	TYP.									
Brightness	(200)									
TIEM	TYP.									
Brightness	(280)									

3.GENERAL DATA

(1) Part Name	TX16D11VM2CAA
(2) Module Dimensions	173.0(W)mm x 70.0(H)mm x (8.6)max.(D)mm
(3) LCD Active Area	148.8(W)mm x 53.76(H)mm
(4) Dot Pitch	0.0775(W)mm x 3(R,G,B)(W) x 0.224(H)mm
(5) Resolution	640 x 3(R,G,B))(W) x 240(H) dots
(6) Color Pixel Arrangement	R,G,B Vertical stripe
(7) LCD Type	Transmissive Color TFT LCD (Normally White)
(8) Display Type	Active Matrix
(9) Number of Colors	262k Colors (R,G,B 6bit parallel)
(10) Backlight	Cold Cathode Fluorescent Tube (CFL) x 1 Average life time 50kh at 25°C IL=5mA
(11) Weight	(140)g
(12) Interface	40pin (C-MOS)
(13) Power Supply Voltage	3.3V only (Include Timing Controller and Power Unit)
(14) Touch Panel	Resistance Type The surface is antiglare type.
(15) Viewing Direction	12 O'clock

4. ABSOLUTE MAXIMUM RATINGS

4.1 ELECTRICAL ABSOLUTE MAXIMUM RATINGS OF LCD

VSS=0V

ITEM	SYMBOL	MIN.	MAX.	UNIT	COMMENT
Power Supply for Logic	VDD	-0.3	4.0	V	
Input Voltage	VI	-0.2	VDD+0.2		(Note 1)
Input Current	Ii	0	1	A	
Static Electricity	VESD0	-	(±100)	V	(Note 2,3)
	VESD1	-	(±8)	kV	(Note 2,4)

Note 1 : DTMG,DCLK,RD0~RD5,GD0~GD5,BD0~BD5.

Note 2 : 200pF-250Ω 25°C - 70%RH

Note 3 : Interface Pin Connector.

Note 4 : The surface of metal bezel and LCD panel .

4.2 ENVIRONMENTAL ABSOLUTE MAXIMUM RATINGS

ITEM	OPERATING		STORAGE		COMMENT
	MIN.	MAX.	MIN.	MAX.	
Ambient Temperature	0°C	50°C	-20°C	60°C	(Note 2,3,6)
Humidity	(Note 1)		(Note 1)		Without condensation
Vibration	-	4.9m/s ² (0.5G)	-	19.6m/s ² (2G) (Note 5)	(Note 4)
Shock	-	29.4m/s ² (3G)	-	490m/s ² (50G) (Note 5)	XYZ directions (Note 7,8)
Corrosive Gas	Not Acceptable		Not Acceptable		

Note 1 : Ta ≤ 40°C :85%RH max.

Ta > 40°C :Absolute humidity must be lower than the humidity of 85%RH at 40°C.

Note 2 : Ta at -20°C for 48h , at 60°C for 168h.

Note 3 : Background color changes slightly depending on ambient temperature.
This phenomenon is reversible.

Note 4 : 5Hz~100Hz(Except resonance frequency)

Note 5 : This LCM will resume normal operation after finishing the test.

Note 6 : The response time will be slower as low temperature.

Note 7 : Pulse Width : 10ms

Note 8 : The module has no mounting hole.

It should be fixed by the way of sandwiching-like method. (Fig.1)

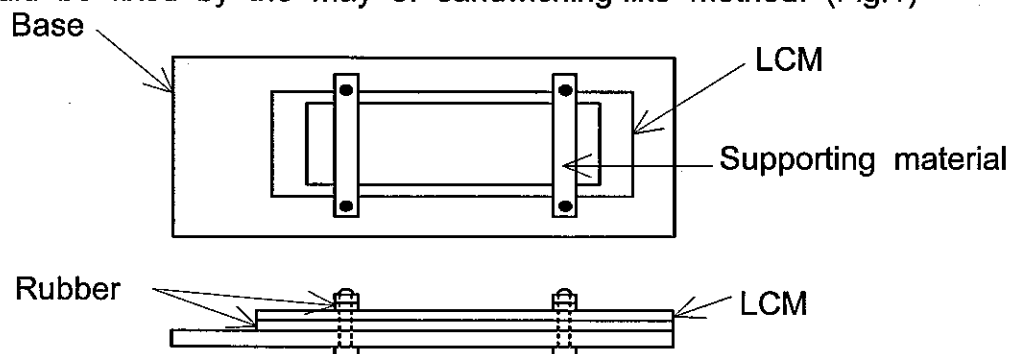

Fig.1

5. ELECTRICAL CHARACTERISTICS

5.1 ELECTRICAL CHARACTERISTICS OF LCD

Ta=25°C, VSS=0V

ITEM	SYMBOL	CONDITION	MIN.	TYP.	MAX.	UNIT
Power Supply Voltage	VDD	-	3.0	3.3	3.6	V
Input Voltage for Logic (Note 1)	VI	"H" level	2.0	-	VDD	V
		"L" level	VSS	-	0.8	
Power Supply Current (Note 2)	IDD for HVGA Display Mode	VDD-VSS=3.3V	-	(94)	-	mA
	IDD for VGA Display Mode		-	(110)	-	
Vsync Frequency	fV	-	(52)	(60)	(68)	Hz
Hsync Frequency	fH for HVGA Display Mode	-	(12.8)	(15.1)	(36.1)	kHz
	fH for VGA Display Mode	-	(25.3)	(29.5)	(36.1)	
DCLK Frequency	fCLK for HVGA Display Mode	-	(8.7)	(10.7)	(26.7)	MHz
	fCLK for VGA Display Mode	-	(17.2)	(20.9)	(26.7)	

Note 1 : DTMG, DCLK, RD0~RD5, GD0~GD5, BD0~BD5.

Note 2 : fV=60Hz, Ta=25°C, Pattern used as display pattern : All Black.

Note 3 : Need to make sure of flickering and rippling of display when setting the frame frequency in your set.

5.2 ELECTRICAL CHARACTERISTICS OF TOUCH PANEL

5.2.1 ELECTRICAL CHARACTERISTICS

ITEM	SPECIFICATION	NOTE
Resistance Between Terminal	X1-X2	(630~1610)Ω
	Y1-Y2	(110~340)Ω
Insulation Resistance	X-Y	20MΩ min. Operating Voltage : 25V DC
Linearity	X	1.5% max. (Note 1,2,3)
	Y	1.5% max.
Chattering	10ms max.	

5.2.2 MECHANICAL CHARACTERISTICS

ITEM	SPECIFICATION	NOTE
Pen Input Pressure	1.0N max.	R0.8mm polyacetal pen
Surface Hardness	3H min.	JIS K5400

5.2.3 OPTICAL CHARACTERISTICS

ITEM	SPECIFICATION	NOTE
Transparency	80% min.	

Note 1 : Operating Voltage 5V DC.

Note 2 : Test Condition.

(a) Y axis linearity testing method (with tip radius 0.8, polycetal pen). $V_{x1-x2}=5V$, $V_{OUT}=V_{y1}$.

(b) X axis linearity method $V_{y1-y2}=5V$, $V_{OUT}=V_{x1}$.

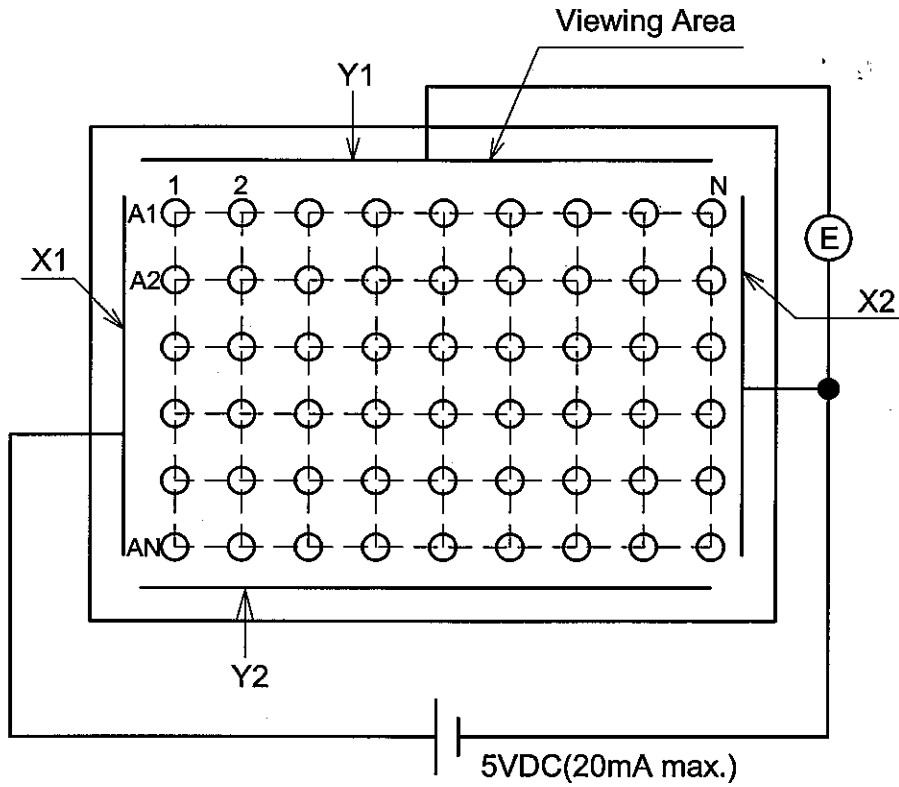

Note 3 : Calculation

(a) Y axis linearity

$$\text{Linearity} = \frac{\Delta E \text{ max.}}{EA1 - EA10} \times 100(\%)$$

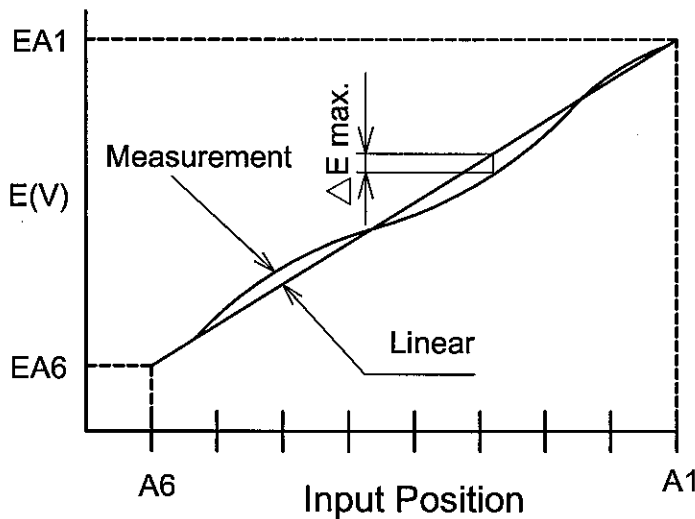

5.3 ELECTRICAL CHARACTERISTICS OF BACKLIGHT

ITEM	SYMBOL	MIN.	TYP.	MAX.	UNIT	NOTE
Lamp Voltage	VL	-	(450)	-	Vrms	Ta=25°C
Frequency	fL	-	(55)	-	kHz	
Lamp Current (1Lamp)(Note 7)	IL	(2.0)	(5.0)	(7.0)	mA	Ta=25°C
Starting Discharge Voltage	VS (Note 2)	(1300)	-	-	Vrms	Ta=0°C

Note 1 : Please design your lamp driving circuit (inverter) based on the above specifications, and inform HITACHI about it.

Note 2 : Starting discharge voltage is increased when LCM is operating under low temperature.

Please check the characteristics of your inverter before applying to your set.

Note 3 : Average life time of CFL will be decreased when LCM is operating under low temperature.

Note 4 : Under lower driving frequency of an inverter, a certain Backlight system (CFL & CFL reflection sheet) may generate a sound noise. Before designing the inverter, please consider the driving frequency and noise.

Note 5 : When IL is over 7.0mA, it may cause uneven contrast near CFL location, due to heat dispersion form CFL.

Note 6 : We recommend to equip protection circuit (To stop output) which works under abnormal operation to the inverter for CFL.

6. OPTICAL CHARACTERISTICS

6.1 OPTICAL CHARACTERISTICS OF LCD

Ta=25°C (Backlight on)

ITEM		SYMBOL	CONDITION	MIN.	TYP.	MAX.	UNIT	NOTE
Viewing Area		θx	$\phi=0^\circ, K \geq 5.0$	-	70	-	deg	1~5
		$\theta x'$	$\phi=180^\circ, K \geq 5.0$	-	70	-	deg	1~5
		θy	$\phi=90^\circ, K \geq 5.0$	-	60	-	deg	1~5
		$\theta y'$	$\phi=270^\circ, K \geq 5.0$	-	70	-	deg	1~5
Contrast Ratio		K	$\phi=0^\circ, \theta=0^\circ$	(100)	(200)	-	-	5
Response Time (rise+fall)		tr+tf	$\phi=0^\circ, \theta=0^\circ$	-	(45)	-	ms	6
Color Tone (Primary Color)	Red	x	$\phi=0^\circ, \theta=0^\circ$	0.57	0.62	0.67	-	
		y		0.29	0.34	0.39	-	
	Green	x		0.25	0.30	0.35	-	
		y		0.54	0.59	0.64	-	
	Blue	x		0.09	0.14	0.19	-	
		y		0.04	0.09	0.14	-	
	White	x		0.24	0.29	0.34	-	
		y		0.26	0.31	0.36	-	

(Measurement condition : HITACHI standard)
(Note 3~6) : See next page.

Note 1 : Driving Condition
Display Pattern : White Raster
ICFL Current : (5)mA

Note 2 : Measurement Condition
(Transmittance)

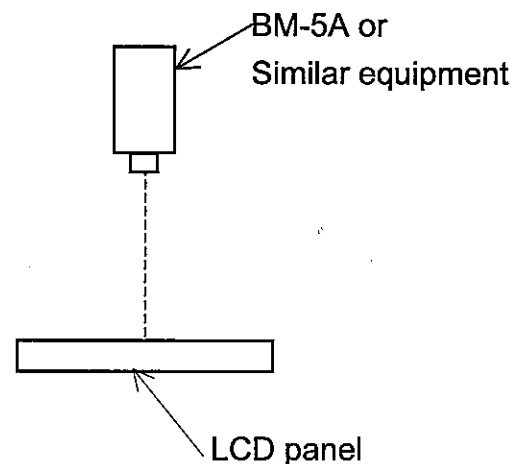

Note 3 : Definition of θ and ϕ
(Normal)
Viewing direction

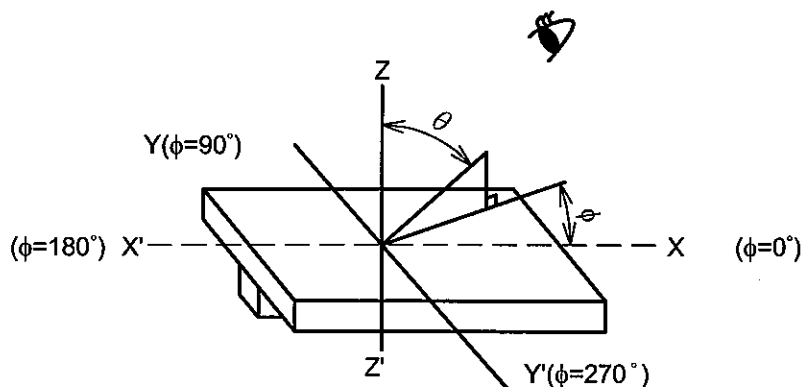

Note 5 : Definition of contrast "K"

$$K = \frac{\text{White Brightness}}{\text{Black Brightness}}$$

Note 4 : Definition of Viewing angle ϕ_1 and ϕ_2

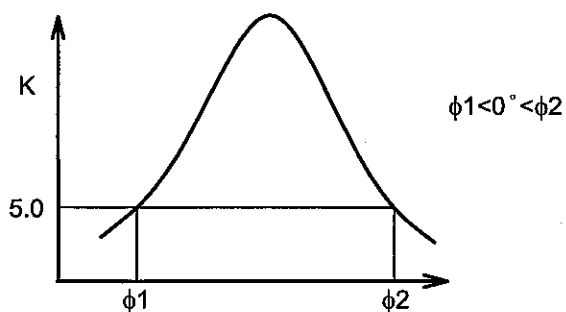

Contrast ratio "K" vs Viewing angle " ϕ "

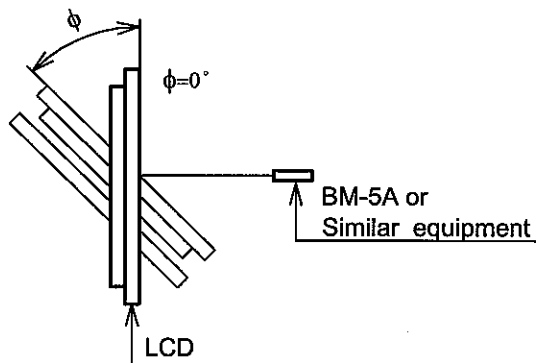

Note 6 : Definition optical response time

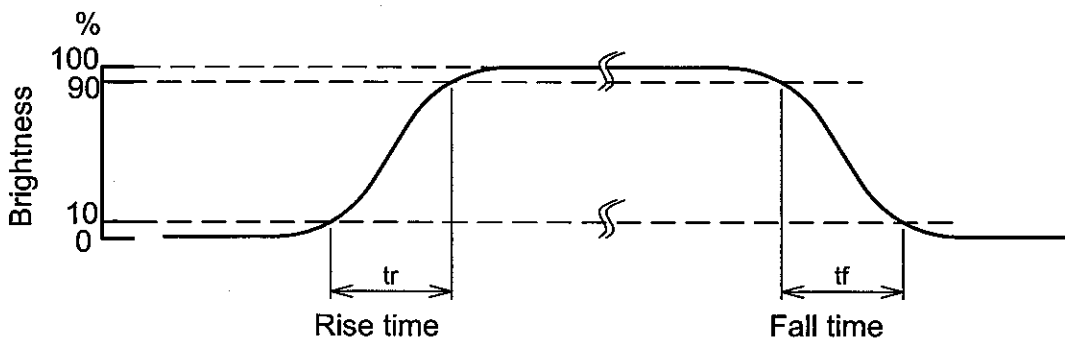
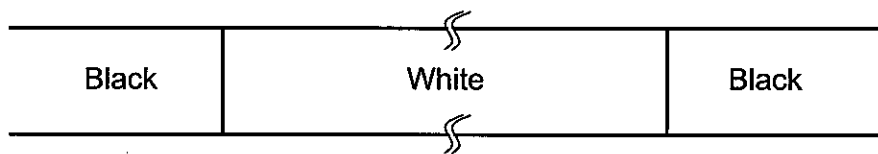

6.2 OPTICAL CHARACTERISTICS OF BACKLIGHT

ITEM	MIN.	TYP.	MAX.	UNIT	NOTE
Brightness	-	(280)	-	cd/m ²	IL=(5)mA (Note 1,2)
Rise Time	-	(3)	-	Minute	IL=(5)mA Brightness 80%
Brightness Uniformity	-	-	(±25)	%	Under mentioned (Note 1,3,4)

(Measurement condition : HITACHI standard)

CFL: 0h operation, Ta=25°C

Display data should all be "ON"

Note 1 : Measurement after 10 minutes from CFL operating.

Average value of 9 points (Note 3)

Note 2 : Brightness control : 100%.

Note 3 : Measurement of the following 9 places on the display.

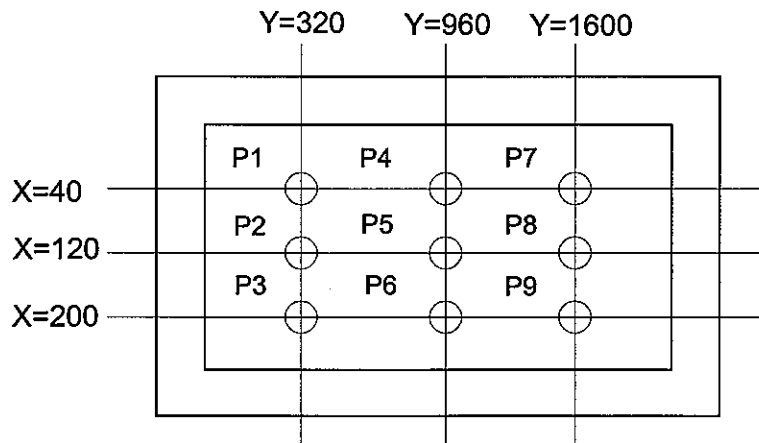

Note 4 : Definition of the brightness tolerance.

$$\left(\frac{\text{Max. brightness or Min. brightness} - \text{Average brightness}}{\text{Average brightness}} \right) \times 100$$

7.BLOCK DIAGRAM

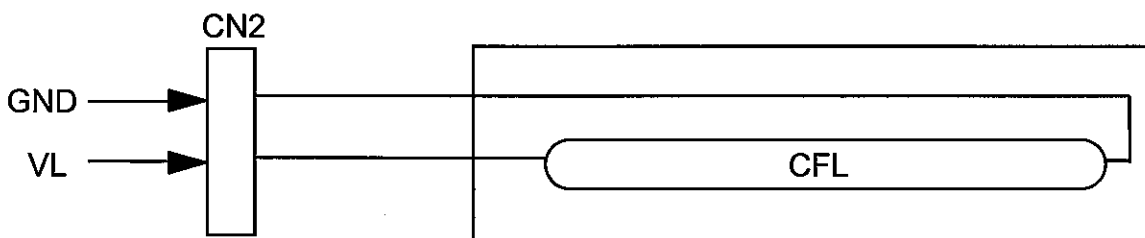
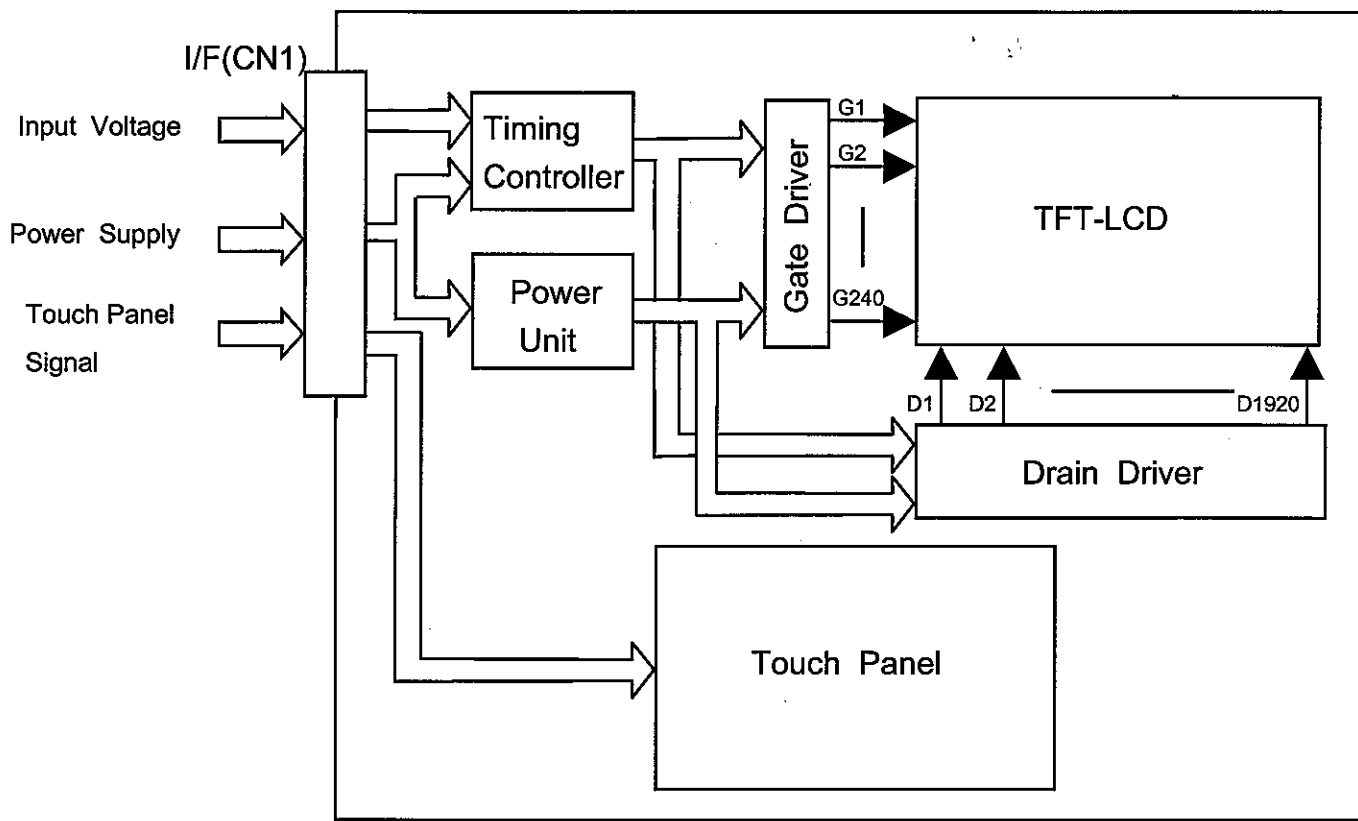

8.INTERFACE TIMING

8.1.1 INTERFACE TIMING FOR HVGA DISPLAY MODE

ITEM		MIN.	TYP.	MAX.	UNIT	SYMBOL	REMARKS
DCLK	Cycle time	37.5	(94)	114.9	ns	tCLK	
	Low level Width	15	-	-		twCL	
	High level Width	15	-	-		twCH	
	Rise time	-	-	25		trCLK	
	Fall time	-	-	25		tfCLK	
	Duty	0.45	0.5	0.55	-	D	D= tCLK/CLK
Hsync	Set up time	5	-	-	ns	tSH	for DCLK
	Hold time	10	-	-		tHH	
	Cycle	679	(709)	739	tCLK	tHP	
	Valid width	4	5	5		tWH	
	Rise/Fall time	-	-	30	ns	T _r ,t _f	
Vsync	Set up	0	-	-	tCLK	tSV	for Hsync
	Hold	2	-	-		tHV	
	Cycle	245	(251)	533	tHP	tVP	
	Valid width	2	2	2		tWV	
	Rise/Fall time	-	-	50	ns	t _v ,t _v	
DTMG	Set up time	5	-	-	ns	tSI	for DCLK
	Hold time	10	-	-		tHI	
	Rise/Fall time	-	-	30	ns	T _r ,t _f	
	Horizontal back porch	24	(37)	50	tCLK	tHBP	
	Horizontal front porch	15	(32)	49		tHFP	
	Vertical back porch	4	(7)	196	tHP	tVBP	
	Vertical front porch	1	(4)	97		tVFP	
Data	Set up time	5	-	-	ns	tSD	for DCLK
	Hold time	10	-	-		tHD	
	Rise/Fall time	-	-	25	ns	T _{Dr} ,t _{Df}	

Note : Vsync Cycle No. should be set to odd.

8.1.2 INTERFACE TIMING FOR VGA DISPLAY MODE

ITEM		MIN.	TYP.	MAX.	UNIT	SYMBOL	REMARKS
DCLK	Cycle time	37.4	(47.8)	58.1	ns	tCLK	
	Low level Width	15	-	-		twCL	
	High level Width	15	-	-		twCH	
	Rise time	-	-	25		trCLK	
	Fall time	-	-	25		tfCLK	
	Duty	0.45	0.5	0.55	-	D	D= tCLK/ CLK
Hsync	Set up time	5	-	-	ns	tSH	for DCLK
	Hold time	10	-	-		tHH	
	Cycle	679	(709)	739	tCLK	tHP	
	Valid width	4	5	5		tWH	
	Rise/Fall time	-	-	30	ns	T _{hr} ,t _{hf}	
Vsync	Set up	0	-	-	tCLK	tSV	for Hsync
	Hold	2	-	-		tHV	
	Cycle	485	(491)	533	tHP	tVP	
	Valid width	2	2	2		tWV	
	Rise/Fall time	-	-	50	ns	t _{vr} ,t _{vf}	
DTMG	Set up time	5	-	-	ns	tSI	for DCLK
	Hold time	10	-	-		tHI	
	Rise/Fall time	-	-	30	ns	T _{lr} ,t _{lf}	
	Horizontal back porch	24	(37)	50	tCLK	tHBP	
	Horizontal front porch	15	(32)	49		tHFP	
	Vertical back porch	4	(7)	28	tHP	tVBP	
	Vertical front porch	1	(4)	25		tVFP	
Data	Set up time	5	-	-	ns	tSD	for DCLK
	Hold time	10	-	-		tHD	
	Rise/Fall time	-	-	25	ns	T _{Dr} ,t _{Df}	

Note : Vsync Cycle No. should be set to odd.

8.2 TIMING CHART

(Data is latched negative edge trigger of DCLK)

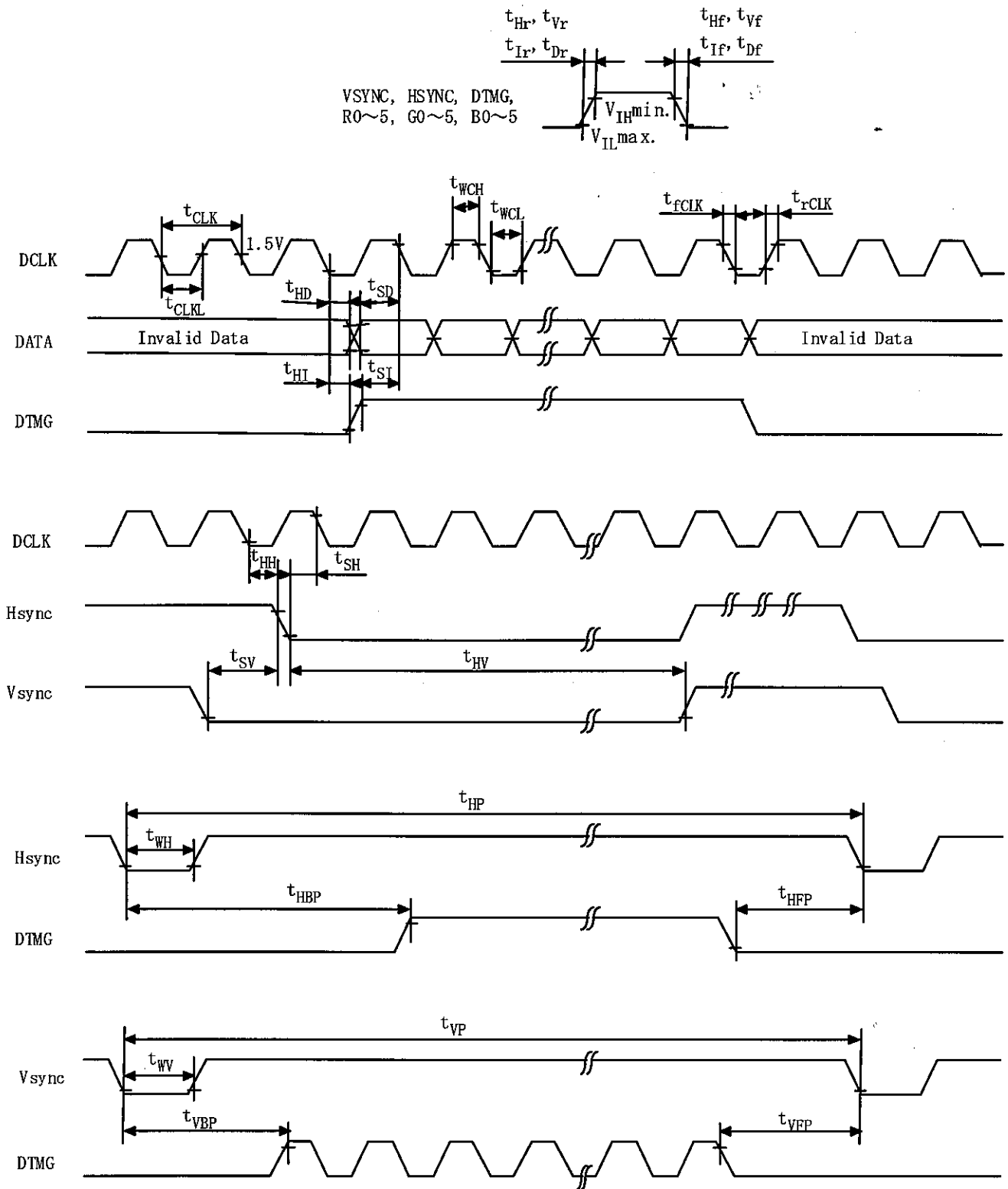

Note 1 : DTMG is definition of the above timing for Hsync and Vsync.

Note 2 : No matter when Hsync and Vsync is inputted ,this LCM can be drove only DTMG Signal. DTMG should be set to low level when it is not input valid data.

8.3 POWER ON/OFF SEQUENCE

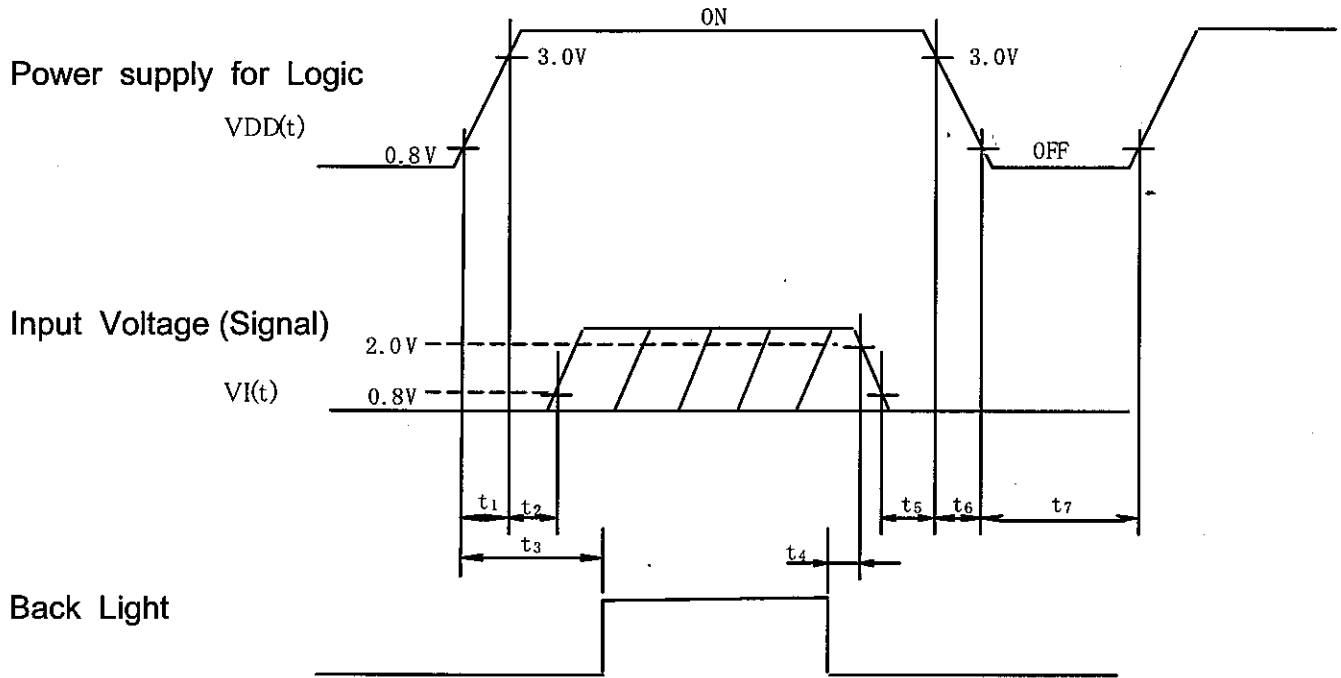

POWER ON

$t_1 \leq 15\text{ms}$
 $0\text{ms} < t_2 \leq 45\text{ms}$
 $0.1\text{s} \leq t_3$

POWER OFF

$5\text{ms} \leq t_4$
 $0\text{ms} \leq t_5 \leq 45\text{ms}$
 $0\text{ms} \leq t_6 \leq 20\text{ms}$
 $0.4\text{s} \leq t_7$

Note 1 : $0\text{V} \leq VI(t) \leq VDD(t)$

VI(t) and VDD(t) is a surfeit of condition for power on/off.

Note 2 : Input Voltage(Signal) should not be set high impedance when power on.

8.4 RELATIONSHIP BETWEEN DISPLAYED COLOR AND INPUT DATA

	COLOR & GRAY SCALE	GRAY SCALE LEVELS	DATA SIGNAL																	
			R0	R1	R2	R3	R4	R5	G0	G1	G2	G3	G4	G5	B0	B1	B2	B3	B4	B5
Basic Color	Black	-	0	0	0	0	0	0	0	0	0	0	0	0	0	0	0	0	0	0
	Blue	-	0	0	0	0	0	0	0	0	0	0	0	0	1	1	1	1	1	1
	Green	-	0	0	0	0	0	0	1	1	1	1	1	1	0	0	0	0	0	0
	Cyan	-	0	0	0	0	0	0	1	1	1	1	1	1	1	1	1	1	1	1
	Red	-	1	1	1	1	1	1	0	0	0	0	0	0	0	0	0	0	0	0
	Magenta	-	1	1	1	1	1	1	0	0	0	0	0	0	1	1	1	1	1	1
	Yellow	-	1	1	1	1	1	1	1	1	1	1	1	1	0	0	0	0	0	0
	White	-	1	1	1	1	1	1	1	1	1	1	1	1	1	1	1	1	1	1
Red	Black	GS0	0	0	0	0	0	0	0	0	0	0	0	0	0	0	0	0	0	0
	↑	GS1	1	0	0	0	0	0	0	0	0	0	0	0	0	0	0	0	0	0
	Darker	GS2	0	1	0	0	0	0	0	0	0	0	0	0	0	0	0	0	0	0
	↕	↓	↓																	
	↕	↓	↓																	
	Brighter	GS61	1	0	1	1	1	1	0	0	0	0	0	0	0	0	0	0	0	0
	↓	GS62	0	1	1	1	1	1	0	0	0	0	0	0	0	0	0	0	0	0
	Red	GS63	1	1	1	1	1	1	0	0	0	0	0	0	0	0	0	0	0	0
Green	Black	GS0	0	0	0	0	0	0	0	0	0	0	0	0	0	0	0	0	0	0
	↑	GS1	0	0	0	0	0	0	1	0	0	0	0	0	0	0	0	0	0	0
	Darker	GS2	0	0	0	0	0	0	0	1	0	0	0	0	0	0	0	0	0	0
	↕	↓	↓																	
	↕	↓	↓																	
	Brighter	GS61	0	0	0	0	0	0	1	0	1	1	1	1	0	0	0	0	0	0
	↓	GS62	0	0	0	0	0	0	0	1	1	1	1	1	0	0	0	0	0	0
	Green	GS63	0	0	0	0	0	0	1	1	1	1	1	1	0	0	0	0	0	0
Blue	Black	GS0	0	0	0	0	0	0	0	0	0	0	0	0	0	0	0	0	0	0
	↑	GS1	0	0	0	0	0	0	0	0	0	0	0	1	0	0	0	0	0	0
	Darker	GS2	0	0	0	0	0	0	0	0	0	0	0	0	1	0	0	0	0	0
	↕	↓	↓																	
	↕	↓	↓																	
	Brighter	GS61	0	0	0	0	0	0	0	0	0	0	0	0	1	0	1	1	1	1
	↓	GS62	0	0	0	0	0	0	0	0	0	0	0	0	0	1	1	1	1	1
	Blue	GS63	0	0	0	0	0	0	0	0	0	0	0	0	1	1	1	1	1	1

8.5 INTERNAL PIN CONNECTION

CN1 JAE : FA5B040HP1(Suitable FPC : $t0.3\pm0.05\text{mm}$, $0.5\pm0.05\text{mm}$ pitch)

PIN No.	SIGNAL	FUNCTION
1	VDD	Power Supply for Logic
2	VDD	Power Supply for Logic
3	VDD	Power Supply for Logic
4	VDD	Power Supply for Logic
5	NC	No Connection
6	DTMG	Timing Signal for Data
7	VSS	GND
8	DCLK	Dot Clock
9	VSS	GND
10	NC	No Connection
11	VSS	GND
12	B5	Blue Data
13	B4	
14	B3	
15	VSS	GND
16	B2	Blue Data
17	B1	
18	B0	
19	VSS	GND
20	G5	Green Data
21	G4	
22	G3	
23	VSS	GND
24	G2	Green Data
25	G1	
26	G0	
27	VSS	GND
28	R5	Red Data
29	R4	
30	R3	
31	VSS	GND
32	R2	Red Data
33	R1	
34	R0	
35	Vcom	Common Voltage (Generated by LCM)
36	VSS	GND
37	X1	Analog Signal Touch Panel
38	Y1	Analog Signal Touch Panel
39	X2	Analog Signal Touch Panel
40	Y2	Analog Signal Touch Panel

CN2 JST Housing : BHSR-02VS-1 (Suitable Connector : JST SM02B-BHSS-1)

Contact pin : SBHS-002T-P0.5

PIN No.	SIGNAL	LEVEL	FUNCTION
1	VSS	-	GND for CFL
2	VCFL	-	Power Supply for CFL

9. DIMENSIONAL OUTLINE

9.1 DIMENSIONAL OUTLINE OF LCM

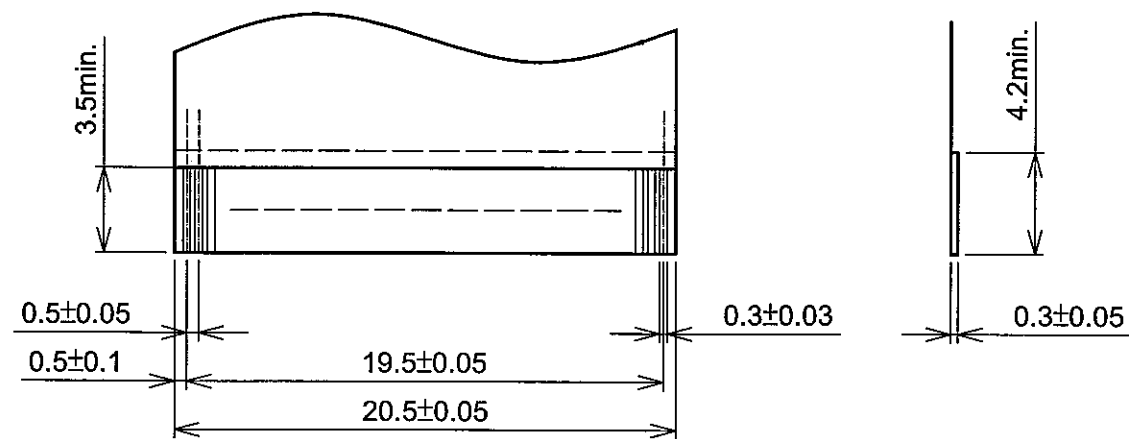
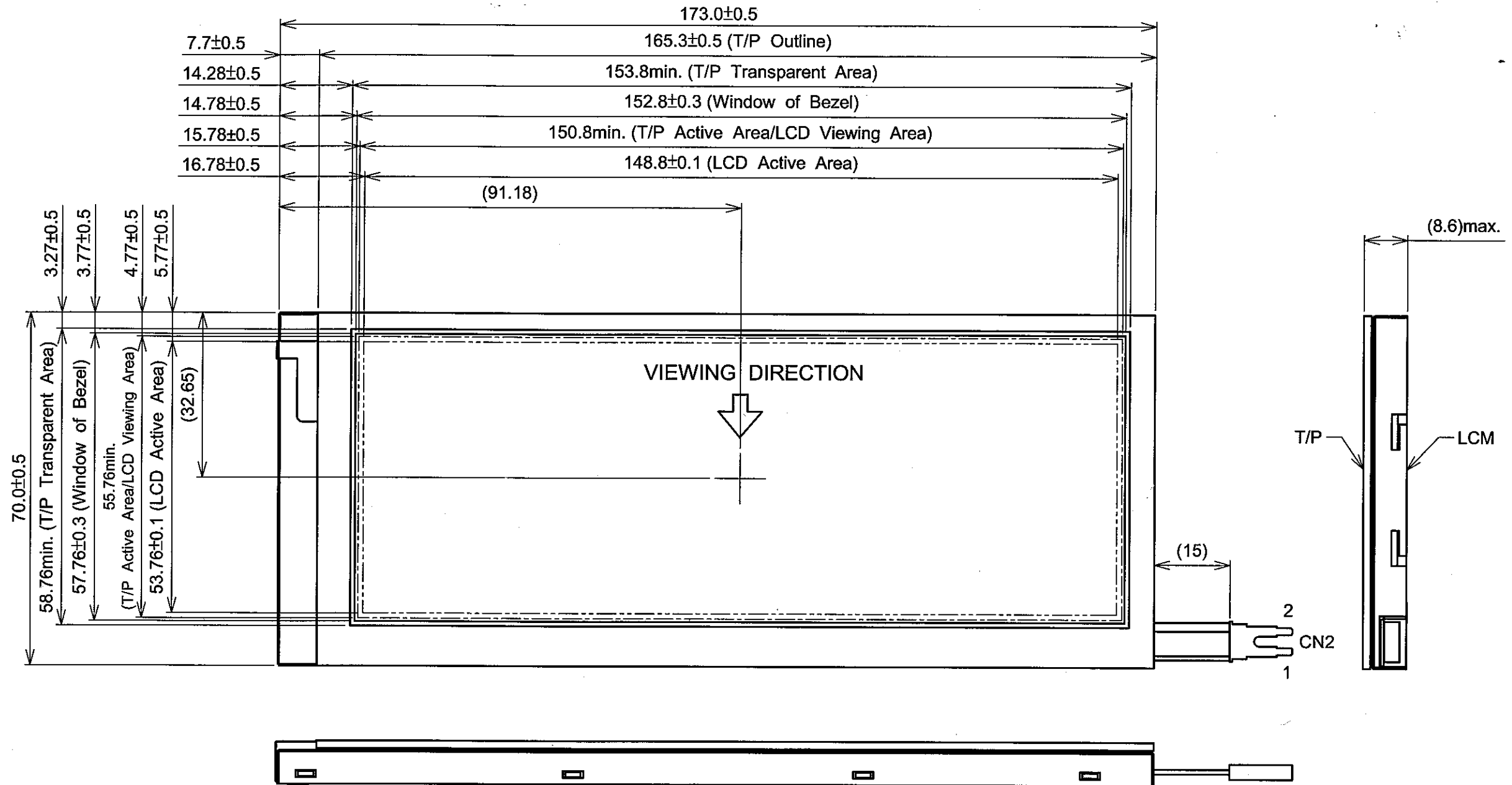

Recommended design rule for I/F FPC

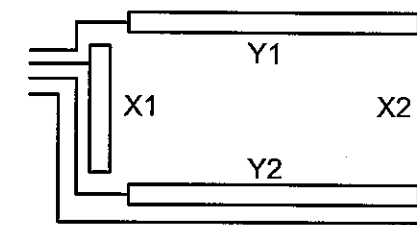

Touch Panel Terminal Assignment.

Scale : NTS
Unit : mm

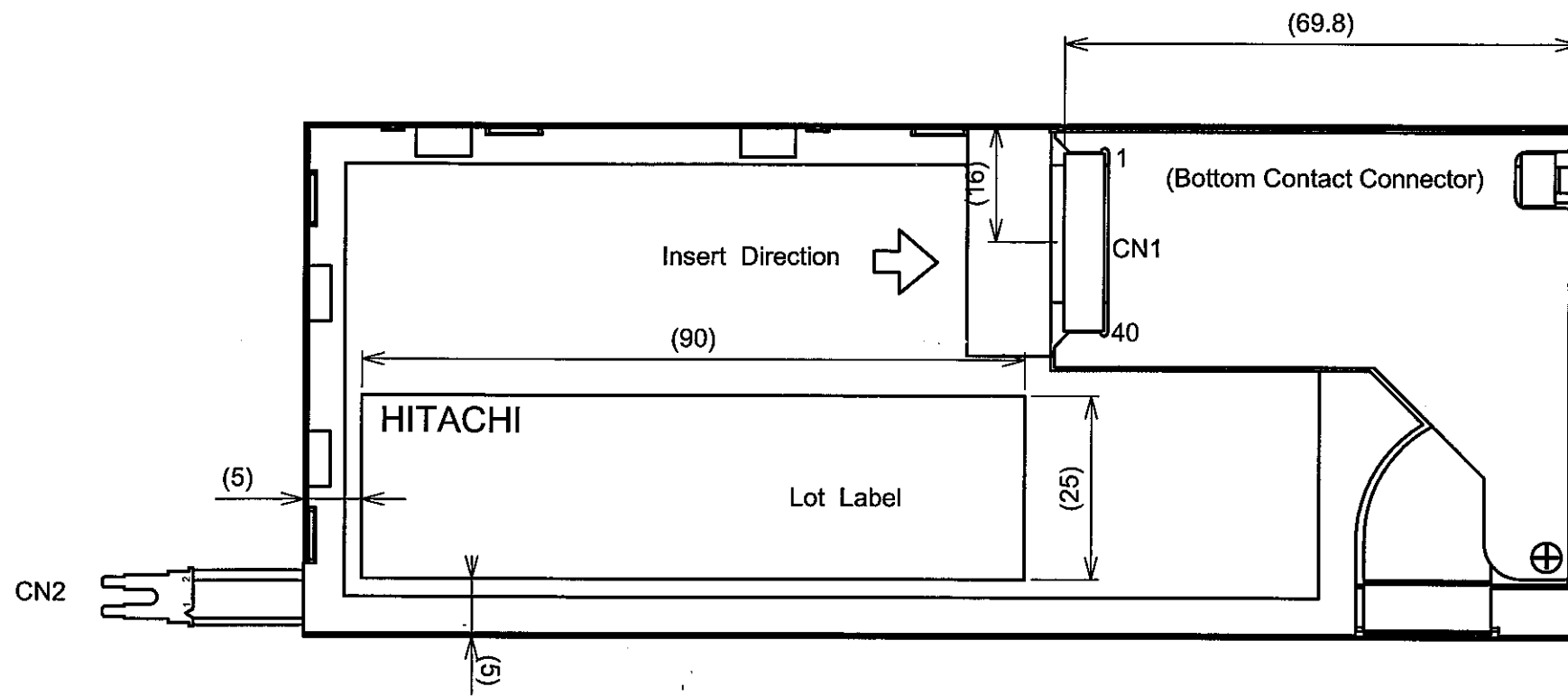

Scale : NTS
Unit : mm

10. APPEARANCE STANDARD

10.1 APPEARANCE INSPECTION CONDITION

Visual inspection should be done under the following condition.

- (1) The inspection should be done in a dark room. (More than 1000(lx) and non-directive)
- (2) The distance between eyes of an inspector and the LCD module is 30cm.
- (3) The viewing zone is shown the figure.

The θ is defined as $\theta \leq 45^\circ$ for LCM power off

$\theta \leq 5^\circ$ for LCM power on

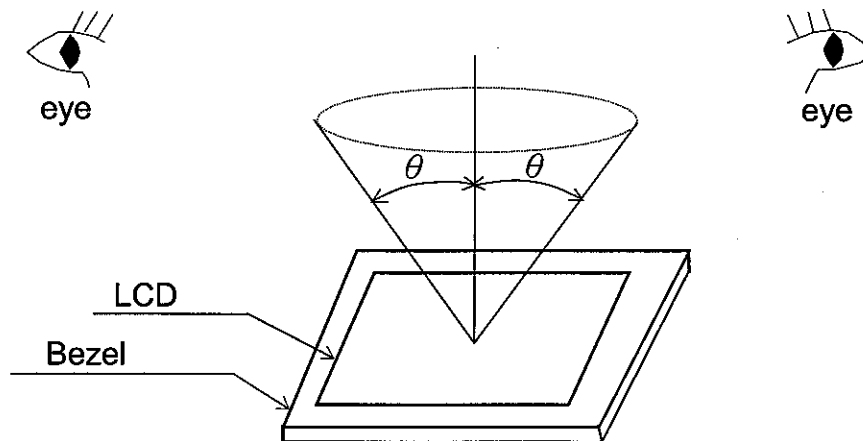

10.2 DEFINITION OF ZONE

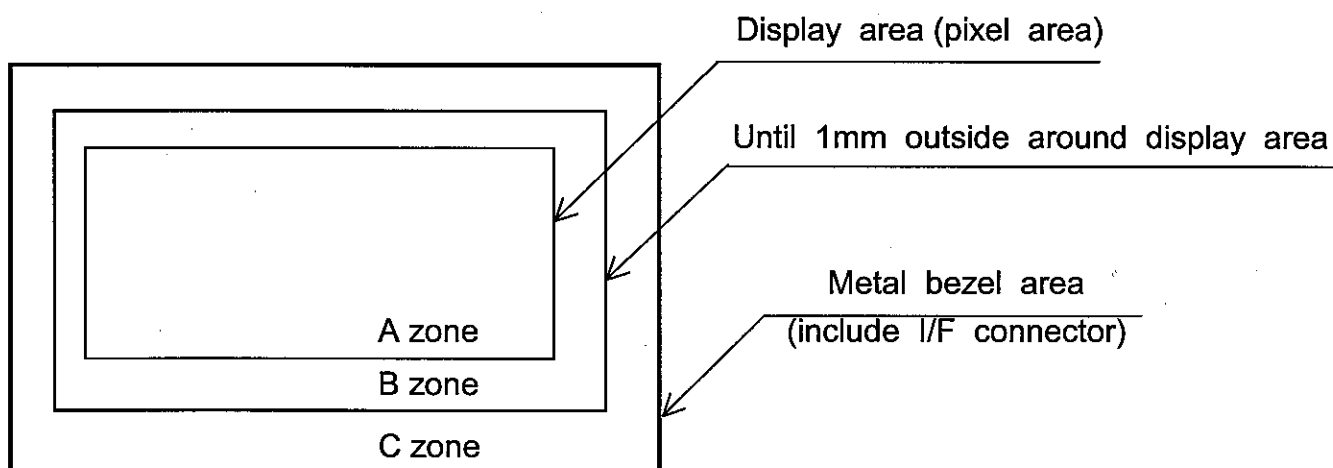

10.3 APPEARANCE SPECIFICATION

(1)LCD Appearance

*) If the problem related to this section occurs about this item, the responsible persons of both party (Customer and HITACHI) will discuss the matter in detail.

No.	ITEM	CRITERIA				APPLIED ZONE
		Length L(mm)	Width W(mm)	Maximum number acceptable	Minimum space	
L C D	Scratches	Ignored	$W \leq 0.02$	Ignored	-	A,B
		$L \leq 40$	$0.02 < W \leq 0.04$	10	-	
		$L \leq 20$	$W \leq 0.04$	10	-	
		Distinguished one is acceptable (To be judged by HITACHI standard)				
	Wrinkles in Polarizer	Same as above				A
	Bubbles	Average diameter D(mm)		Maximum number acceptable		A
		$D \leq 0.2$		Ignored		
		$0.2 < D \leq 0.3$		12		
		$0.3 < D \leq 0.5$		3		
		$0.5 < D$		none		
	Stains Foreign Materials	Filamentous (Line shape)				A,B
		Length L(mm)	Width W(mm)	Maximum number acceptable		
	Dark Spot	$L \leq 2.0$	$W \leq 0.03$	Ignored		
		$L \leq 3.0$	$0.03 < W \leq 0.05$	6		
		$L \leq 2.5$	$0.05 < W \leq 0.1$	1		
	Dot Defect	Round(Dot shape)				A,B
Average diameter D(mm)		Maximum number acceptable	Minimum Space			
$D < 0.2$		Ignored	-			
$0.2 \leq D < 0.3$		10	10 mm			
$0.3 \leq D < 0.4$		5	30 mm			
$0.4 \leq D$		none	-			
The total number		Filamentous + Round=10				
Those wiped out easily are acceptable				A		
Color Tone	To be judged by HITACHI STANDARD				A	
Color Uniformity	Same as above				A	
Dot Defect			Maximum number acceptable		A	
	Sparkle mode	1 dot	4			
		2 dots	1			
		Total (Note.(3)-(f))	5			
	Black mode	1 dot	5			
		2 dots	2			
		Total (Note.(3)-(f))	5			
Total (Note.(3)-(f))	10					

(2) CFL BACKLIGHT APPEARANCE

No.	ITEM	CRITERIA			APPLIED ZONE
C F L	Dark Spots	Average diameter D(mm)		Maximum number acceptable	A
	White Spots	$D \leq 0.4$		ignored	
	Foreign Materials (Spot)	$0.4 < D$		none	
B A C K L I G H T	Foreign Materials (Line)	Width W(mm)	Length L(mm)	Maximum number acceptable	A
		$W \leq 0.2$	$L \leq 2.5$	1	
			$2.5 < L$	None	
$0.2 < W$	-	none			
L I G H T	Scratches	Width W(mm)	Length L(mm)	Maximum number acceptable	A
		$W \leq 0.1$	-	ignored	
		$0.1 < W \leq 0.2$	$L \leq 11.0$	1	
			$11.0 < L$	None	
$0.2 < W$	-	none			

(3) TOUCH PANEL APPEARANCE

ITEM	CRITERIA		
Scratch	$W > 0.1$	-	None
	$0.10 \geq W > 0.05$	$10 < L$	None
	$0.05 \geq W$	-	ignored
Dust(Linear)	$W > 0.10$	-	Dust(Circular)
	$0.10 \geq W > 0.05$	$3 < L$	None
	$0.05 \geq W$	-	ignored
Dust(Circular)	$D > 0.3$		None
	$0.3 \geq D > 0.25$		Maximum 3pcs(Dust to Dust > 20mm)
	$0.25 > D$		ignored

Applied only in the active area. Scratches or dusts in the outside of the active area are acceptable unless the electrical characteristics are affected.

- Dirt
Acceptable if not noticeable on a black mat.
- Tip, crack (applicable to glass only)

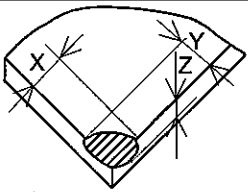
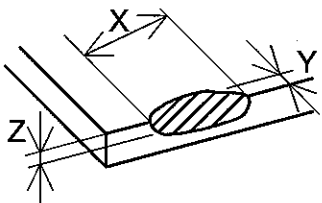
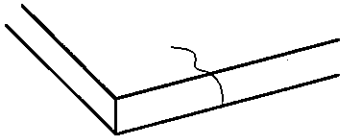
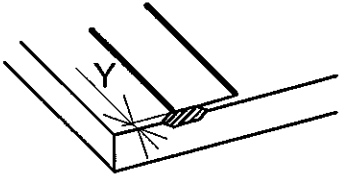
ITEM	CRITERIA			
Tip Corner		X	≤ 2	Not acceptable if the film is damaged
		Y	≤ 5	
		Z	≤ 1.1	
Tip Side		X	≤ 5	Not acceptable if the film is damaged
		Y	≤ 3	
		Z	≤ 1.1	
Crack				None
Other		$Y \leq 1$		Not acceptable if the electrical Characteristics is affected

Blistering Puffiness

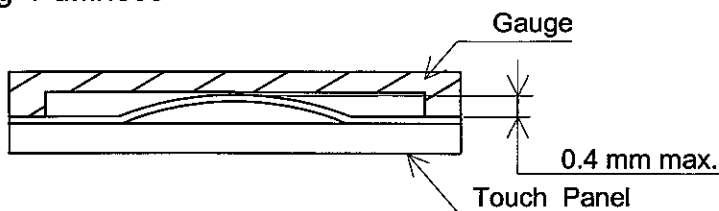

Note 1 : Definition of average diameter (D)

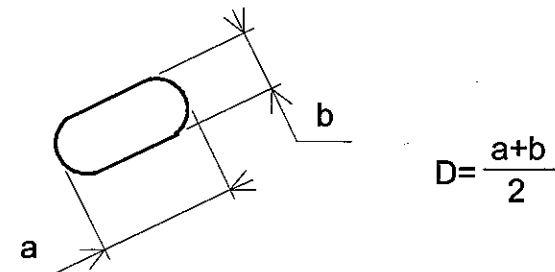

Note 2 : Definition of length (L) and width (W)

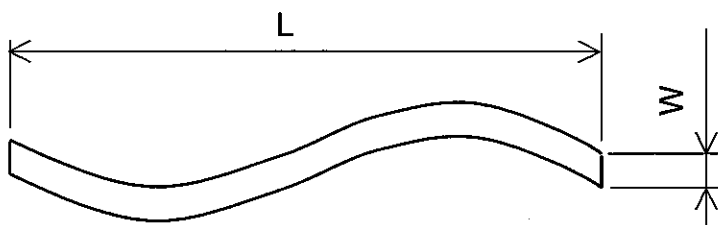

Note 3 : Definition of dot defect

- (a) Dot Defect : Defect Area > 1/2 dot
- (b) Sparkle mode : Brightness of dot is more than 30% at Black raster.
- (c) Black mode : Brightness of dot is less than 70% at R.G.B raster.
- (d) 1 dot : Defect dot is isolated , not attached to other defect dot.
- (e) N dot : N defect dots are consecutive (fig.1).
(N means the number of defect dots.)

(fig .1)

R	G	B	R	G	B	R	G	B
				x				

2 dots defect included defect dot "X" is defined as follows.

Adjacent dots to defect dot "X" : ■

- (f) Counting definition of adjacent dots (1 set) : same as 1 dot defect.
- (g) Those wiped out easily are acceptable.

11. PRECAUTION IN DESIGN

11.1 MOUNTING PRECAUTION

(1) When assembling the Touch Panel and you case, please refer to the figure below.

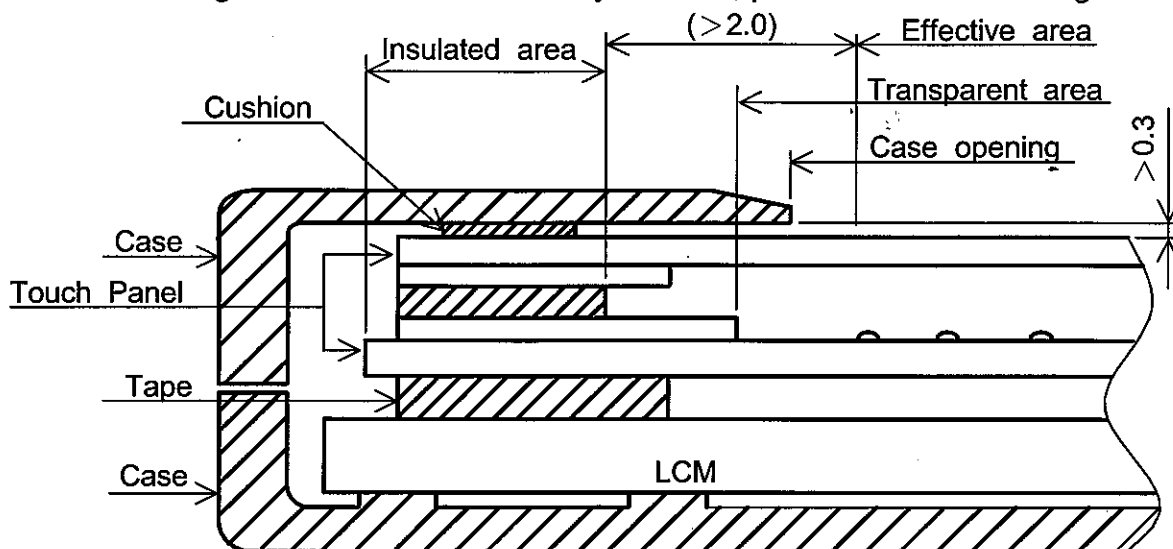

- (2) The clearance between the Touch Panel and case shall be designed so that the case edge never presses the input screen when it is deformed by heat or other causes.
- (3) The case shall be designed not to touch the tail portion (FPC for Touch Panel).
- (4) The boundary space between the effective area and the insulated area is unstable. Touching this area may effect the operation of the Touch Panel. The case must be designed so that it does not touch the boundary space.

11.2 PRECAUTIONS AGAINST ELECTROSTATIC DISCHARGE

As this module contains C-MOS LSIs, it is not strong against electrostatic discharge. Make certain that the operator's body is connected to the ground through a list band, etc. And don't touch I/F pins directly.

11.3 HANDLING PRECAUTIONS

- (1) Since the Touch Panel on the top, and the frame on the bottom tend to be easily damaged, they should be with full care so as not to get them touched, pushed or rubbed by a piece on glass, tweezers and anything else which are harder a pencil lead 2H.
- (2) As the adhesives used for adhering upper/lower polarizer's and frame are made of organic substances which will be deteriorated by a chemical reaction with such chemicals as acetone, toluene, ethanol and isopropyl alcohol. The following are recommended for use :
normal hexane
Please contact with us when it is necessary for you to use chemicals other than the above.

- (3) Lightly wipe to clean the dirty surface with absorbent cotton or other soft material like chamois, soaked in the recommended chemicals without scrubbing it hardly. Always wipe the surface horizontally or vertically. Never give a wipe in a circle. To prevent the display surface from damage and keep the appearance in good state, it is sufficient, in general, to wipe it with absorbent cotton.
- (4) Immediately wipe off saliva or water drop attached on the display area because it may cause deformation or faded color.
- (5) Foggy dew deposited on the surface may cause a damage, stain or dirt to the polarizer.
When you need to take out the LCD module from some place at low temperature for test, etc.
It is required to be warmed them up to temperature higher than room temperature before taking them out.
- (6) Touching the display area or I/F pins with bare hands or contaminating them are prohibited, because the stain on the display area and poor insulation between terminals are often caused by being touched with bare hands.
(Some cosmetics are detrimental to polarizer's.)
- (7) In general, the glass is fragile so that, especially on its periphery, tends to be cracked or chipped in handling. Please not give the LCD module sharp shocks by falling, etc.
- (8) Maximum pressure to the surface must be less than 1.96×10^4 Pa.
And if the pressure area is less than 1cm^2 , maximum pressure must be less than 1.96N.
- (9) Since the metal width is narrow on these locations (see page 9-1/2), please careful with handling.
- (10) Top sheets shall be cleaned gently using a soft cloth such as those used for glasses.
Hard wiping accumulated dust will leave scars on the surface even using a cloth.

11.4 OPERATION PRECAUTION

- (1) Using a LCM module beyond its maximum ratings may result in its permanent destruction.
LCM module's should usually be used under recommended operating conditions shown in chapter 4.
Exceeding any of these conditions may adversely affect its reliability.
- (2) Response time will be extremely delayed at lower temperature than the specified operating temperature range and on the other hand LCD's shows dark blue at higher temperature.
However those phenomena do not main defects of the LCD module. Those phenomena will disappear in the specified operating temperature range.
- (3) If the display area is pushed hard during operation, some display patterns will be abnormally display.

- (4) A slight dew depositing on terminals may cause electrochemical reaction which leads to terminal open circuit. Please operate the LCD module under the relative condition of 40°C 85%RH.
- (5) Resistance range : Your controller shall be set up to allow the resistance range of Touch Panel specified in our CAS.
- (6) Pointed position of Touch Panel may shift owing to a change in resistance of Touch Panel depending on the operation condition . To compensate this shift, the set shall be given a calibration function.
- (7) Input shall be made with a stylus pen (poly acetal , R0.8). Chances are very high that use of a metal piece including a ball point pen or sharp edge will impair accuracy.
- (8) The Touch Panel is an auxiliary input device. The system shall be designed to have other input device.

11.5 STORAGE

In case of storing LCD module for a long period of time (for instance, for years) for the purpose of replacement use, the following precautions necessary.

- (1) Store the LCD modules in a dark place; do not expose them to sunlight or ultraviolet rays.
- (2) Keep the temperature between 10°C and 35°C at normal humidity.
- (3) Store the LCD modules in the container which is used for shipping from us.
- (4) No articles shall be left on the surface over an extended period of time.

11.6 SAFETY

Wear finger cots or gloves whenever handling or assembling a Touch Panel its glass edges are sharp.

11.7 MOUNTING PRECAUTION

- (1) When assembling the LCM Module, please refer to the below.
- (2) The use of cushion is recommended in order to protect the module from shock.
- (3) To prevent the module cover from being pressed, the distance between the case and cushion, should be shorter than 1.0mm.

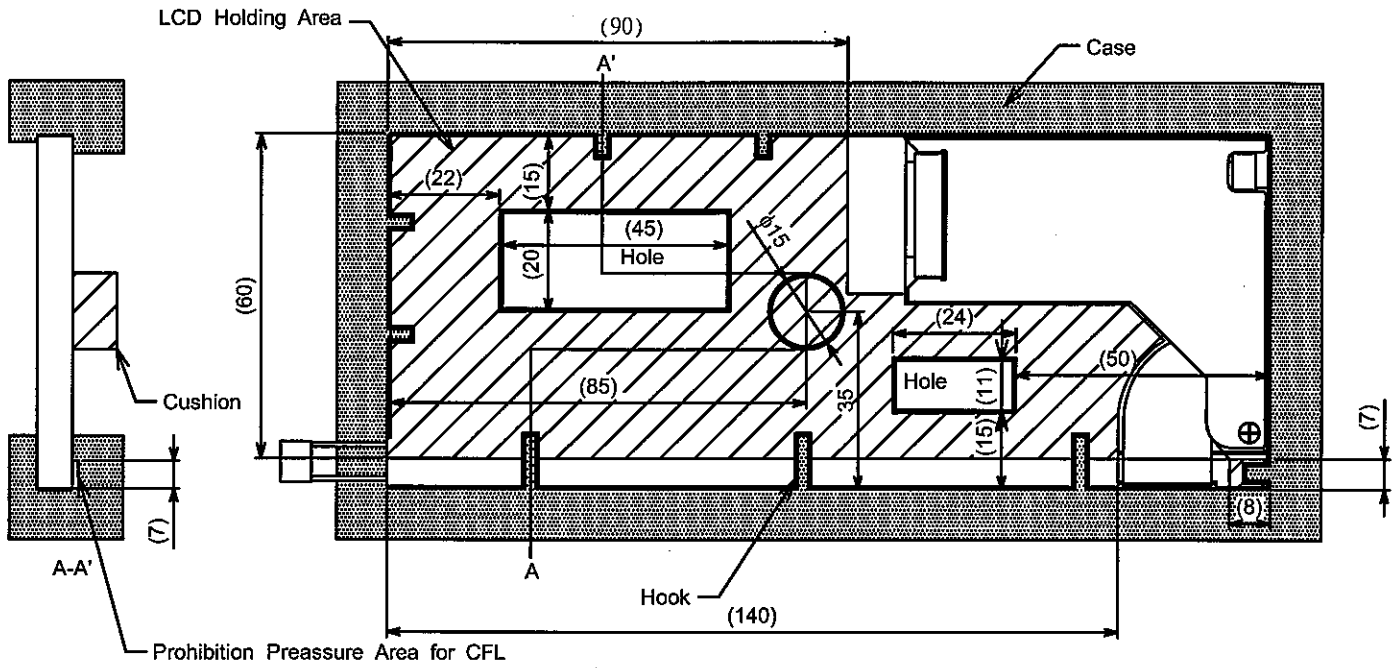

12. DESIGNATION OF LOT MARK

12.1 LOT MARK

Lot mark is consisted of 5 digits for production lot and 5 digits for production control.

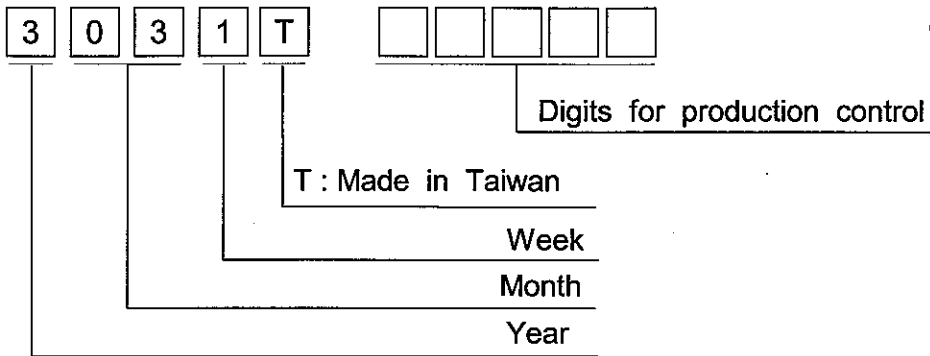

Year	Figure in lot mark
2003	3
2004	4
2005	5
2006	6
2007	7

Month	Figure in lot mark	Month	Figure in lot mark
Jan.	01	Jul.	07
Feb.	02	Aug.	08
Mar.	03	Sep.	09
Apr.	04	Oct.	10
May	05	Nov.	11
Jun.	06	Dec.	12

Week (day in calendar)	Figure in lot mark
1~7	1
8~14	2
15~21	3
22~28	4
29~31	5

12.2 SERIAL No.

Serial No. is consisted of 5 digits number (00001~99999).

12.3 LOCATION OF LOT MARK

Label is bring attached on the back side of module.

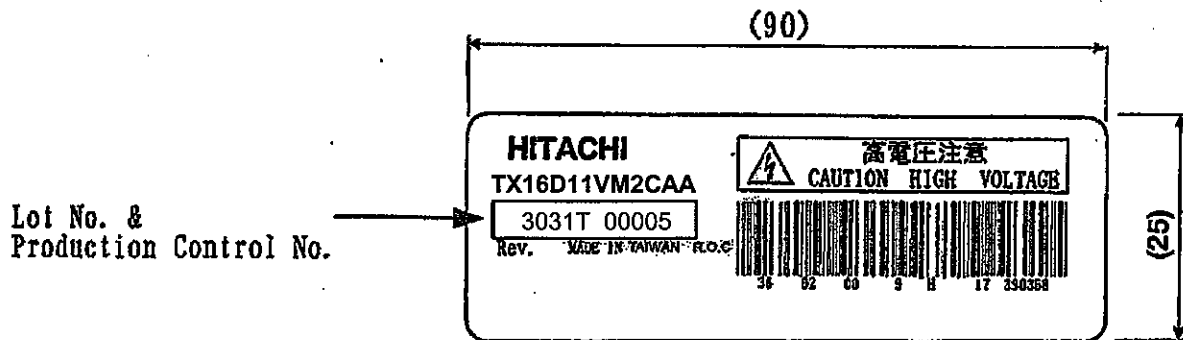

13. PRECAUTION FOR USE

(1) A limit sample should be provided by the both parties on an occasion when the both parties agree to its necessity.

Judgment by a limit sample shall take effect after the limit sample has been established and confirmed by the both parties.

(2) On the following occasions, the handling of the problem should be decided through discussion and agreement between responsible persons of the both parties.

(1) When a question is arisen in the specifications.

(2) When a new problem is arisen which is not specified in this specifications.

(3) When an inspection specifications change or operating condition change by customer is reported to HITACHI, and some problem is arisen in the specification due to the change.

(4) When a new problem is arisen at the customer's operating set for sample evaluation.

(3) Regarding the treatment for maintenance and repairing, both parties will discuss it in six months later after latest delivery of this product.

The precaution that should be observed when handling LCM have been explained above.

If any points are unclear or if you have any requests , please contact with HITACHI.